

Assembly instructions Instrucțiuni de montare

PRODUCT : AQUA WARDROBE 1S+2U

PRODUS : AQUA DULAP 1S+2U

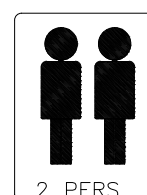
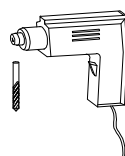
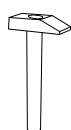
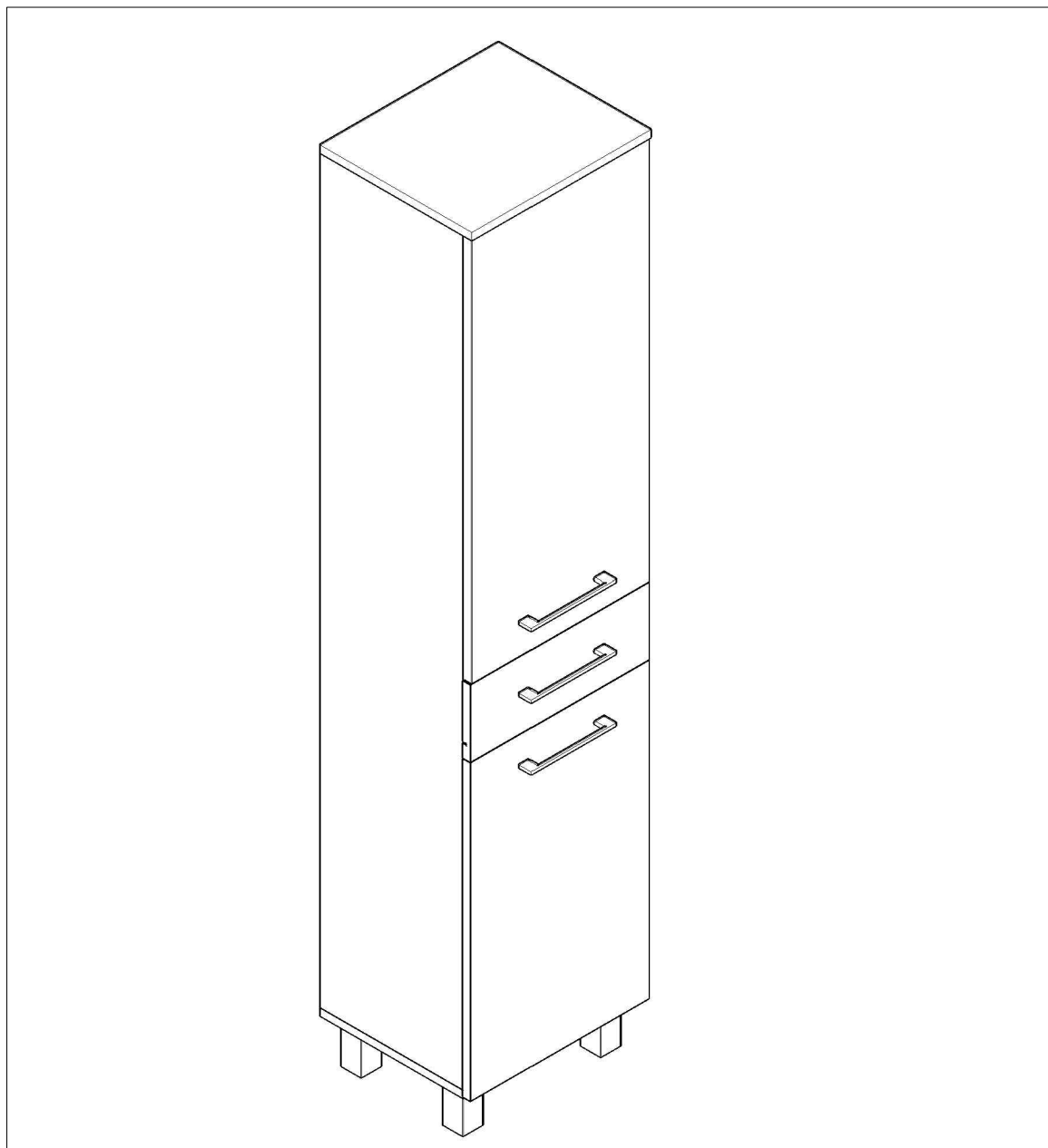

2 PERS.

RO Stimat client,

În calitate de producător de mobilier am dori să vă informăm că o fixare a mobilierului de perete poate fi bună doar dacă legătura dintre materialul de fixare (dibluri) și perete este bună. În cazul corpurilor suspendate verificați pereții și folosiți doar dibluri corespunzătoare tipului de perete (caramida, BCA, rigips, etc.)

achiziționate dintr-un magazin de specialitate. În definitiv montatorul este responsabil de fixarea de perete.

- Montarea și pozarea articolelor electrice se va efectua doar de către personal calificat și autorizat.
- Respectați descrierea și specificațiile de încărcare din instrucțiunile de montaj – în caz de supraîncărcare ce poate să apară datorită copiilor care se joacă, datorită persoanelor, materialului sau datorită altor factori – nu ne asumăm nici o răspundere ca producător de mobilier.
- Nu se va depăși încărcarea maximă de 3kg pe polita!
- Corpurile de mobilier trebuie așezate pe suprafețe orizontale fără denivelări. Doar după aceasta se vor regla ușile. Nu recomandăm montarea mobilierului deasupra sifonului de pardoseală.
- Nu așezați pe suprafețele mobilierului obiecte ude, calde. În caz de stropire cu apă sau diferite substanțe (alcool, săpun lichid, acetona, etc.) ștergeți imediat cu materiale textile moi, absorbante, foarte puțin umezite.
- Mobilierul se păstrează numai în încăperi aerisite, ferit de acțiunea radiațiilor solare și de contactul cu apă. Mobilierul este conceput pentru interior.
- Se recomandă o distanță de minimum 50cm față de sursele de apă. Evitați contactul direct al mobilierului cu apă. Acesta este conceput să reziste la condiții normale de umiditate (abur, stropire accidentală). Expunerea permanentă la un grad ridicat de umiditate va provoca deteriorarea mobilierului (umflare).
- Amplasați mobilierul de baie la distanță de sursele de căldură (calorifer, etc.), distanță de gardă generală este de 20cm.
- Se recomandă ștergerea mobilierului de câte ori este nevoie numai cu materiale moi, uscate și curate.
- Pentru întreținerea componentelor metalice, manerelor și feroneriei se va evita utilizarea de produse abrazive (bureți aspri, solvenți, diluanți, etc.)
- Se recomandă verificarea periodică a instalației sanitare aferente mobilierului de baie pentru a evita eventualele pierderi de apă care ar putea aduce în timp la deteriorarea mobilierului.
- Toate suruburile și elementele de îmbinare demontabile vor trebui verificate și strânse după 5 până la 6 săptămâni pentru a se asigura o siguranță definitivă a fixării.
- Mutarea corpurilor de mobilier se face numai prin ridicarea lor, prinderea corpurilor de mobilier pentru ridicare se face de la bază.
- Racordarea la rețeaua electrică și apă/canal a mobilierului este obligatorie să fie executată exclusiv de către personal autorizat pentru astfel de operațiuni.
- Nu folosiți agenți de curățire abrazivi
- În cazul în care nu se respectă instrucțiunile de utilizare, de deservire sau de montaj, dacă se efectuează modificări ale produselor, dacă se schimbă piese sau se folosesc piese care nu corespund pieselor originale, atunci se pierde orice garanție sau pretenție de responsabilitate din partea producătorului de mobilier.

ENG Dear customer,

As a furniture manufacturer, we would like to inform you that a wall fitting can be good only if the connection between the fixing material (dowels) and the wall is good. In the case of suspended bodies, check the wall and use only dowels corresponding to the type of wall (brick, BCA, rigips, etc.) purchased from a specialist store. Ultimately, the installer is responsible for fixing the wall.

- Installation and placement of electrical items should only be carried out by qualified and authorized personnel.
- Observe the description and loading specifications in the assembly instructions – in the event of overloading that may occur due to children playing due to people, material or other factors – we do not assume any responsibility as a furniture manufacturer.
- Do not exceed the maximum load of 3kg on the shelf!
- Furniture should be placed on horizontal surfaces without bumps. Only after that will the doors be adjusted. We do not recommend fitting the furniture over the floor siphon.
- Do not place hot, wet objects on the furniture surfaces. In case of splashing with water or various substances (alcohol, liquid soap, acetone, etc.), immediately wipe with soft, absorbent, very damp textiles.
- Furniture should only be kept in ventilated rooms, protected from solar radiation and water contact. The furniture is designed for the interior.
- A distance of at least 50cm from water sources is recommended. Avoid direct contact of the furniture with water. It is designed to withstand normal humidity (steam, splashing). Permanent exposure to high humidity will cause furniture damage (swelling).
- Place the bathroom furniture away from the heat sources (radiator, etc.), the general guard distance is 20cm.
- It is recommended to remove the furniture as often as necessary only with soft, dry and clean materials.
- For the maintenance of metal components, handles and fittings, avoid abrasive products (sponge, solvents, thinners, etc.)
- It is advisable to periodically check the sanitary fittings for bathroom furniture to avoid any water loss that could lead to damage to the furniture over time.
- All dismountable screws and fasteners will need to be checked and tightened after 5 to 6 weeks to ensure a secure fit.
- Moving the furniture is done only by lifting it, the attachment of the furniture for lifting is made from the base.
- The connection to the electrical and water / canal of the furniture is obligatory to be carried out exclusively by authorized personnel for such operations.
- Do not use abrasive cleaning agents
- If the instructions for use, servicing or installation are not followed, if product changes are made, parts are changed or parts that do not correspond to the original parts are used, then any warranty or claim of responsibility is lost from furniture maker.

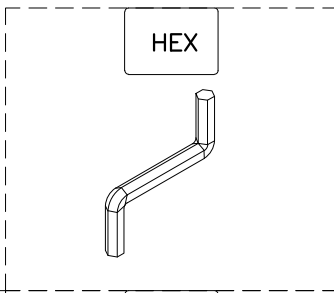
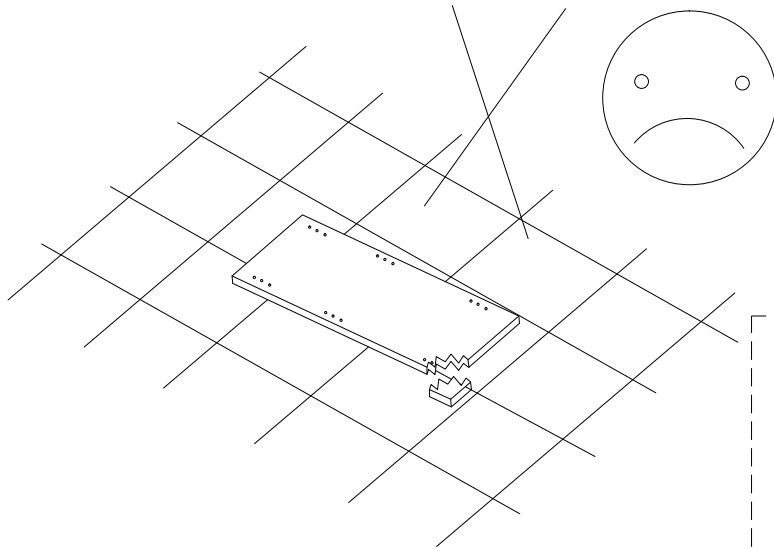
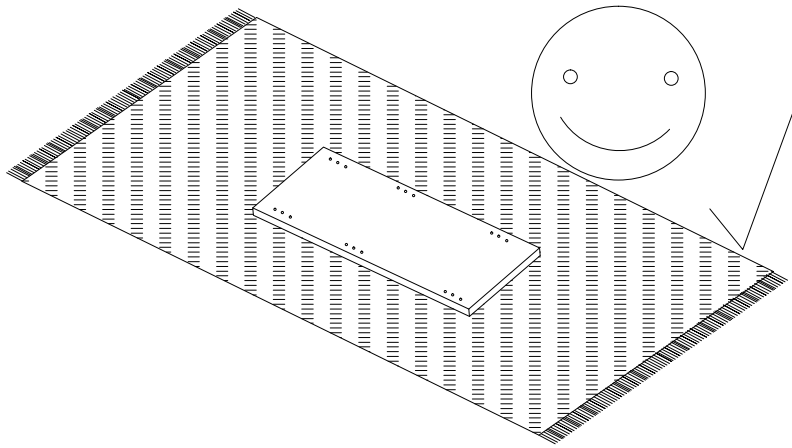

DRW-300

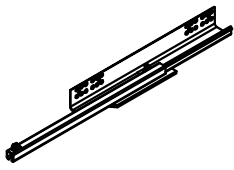

D-003

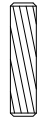

AR

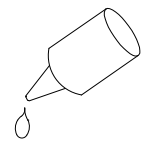

PI

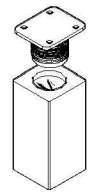

B-01

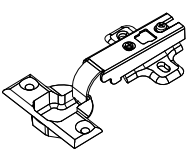

S1-16

ø3.5x16



D-001



C-01

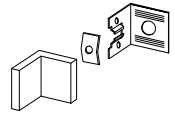

S-001

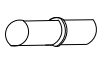

M-04

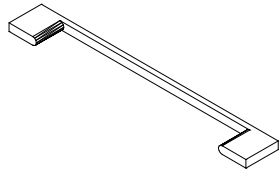

D-002



T-01



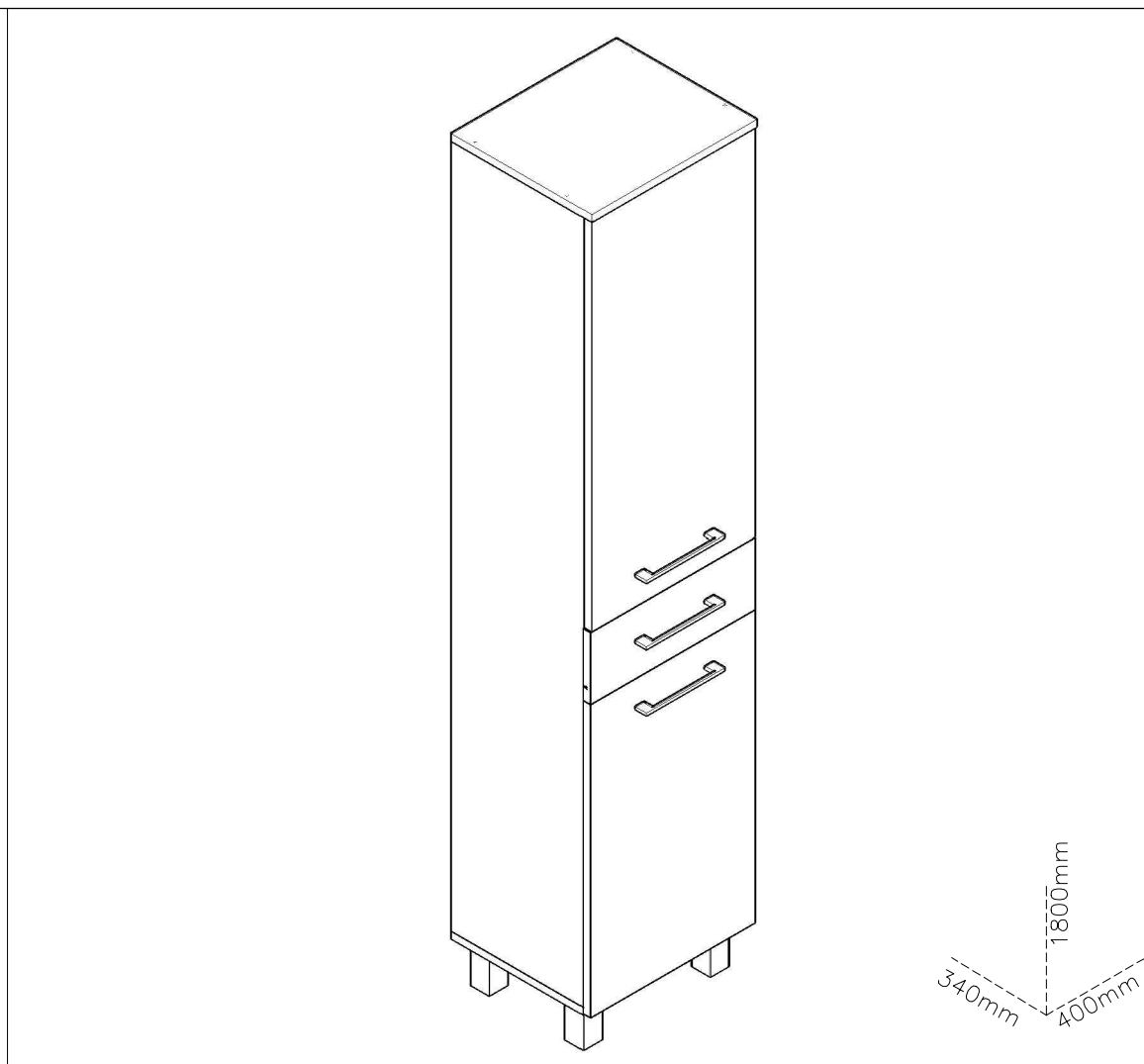

- Materiale:
- Placi din aschii de lemn (PAL), meleminate de grosime = 16 mm
 - Placi din fibre de lemn de inalta densitate (HDF) de grosime = 3 mm
 - Cant ABS 0.5 mm – Carcasa
 - Cant ABS 1 mm – Front
 - Picioar plastic H=100 mm
 - Elemente de imbinare din lemn si metalice
 - Manere metalic
 - Balamale aruncatoare metalice
 - Glisiera cu amortizare

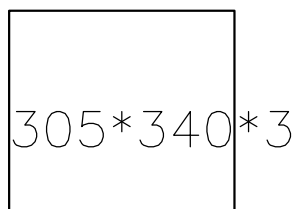
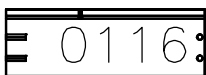
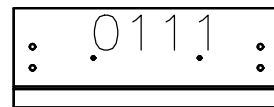
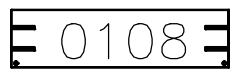
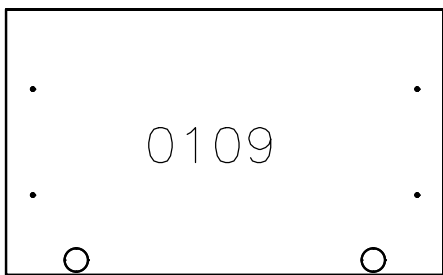
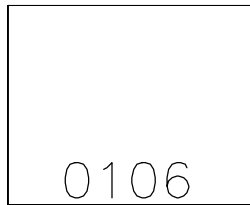
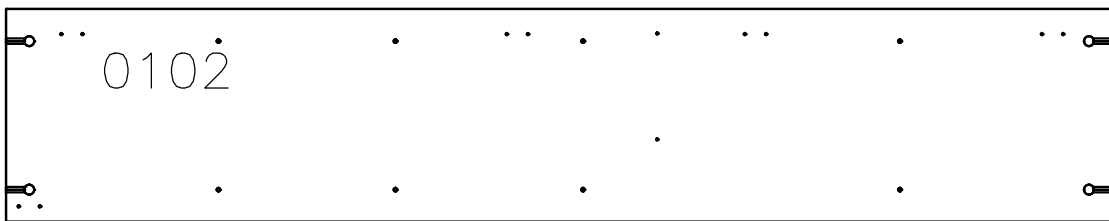
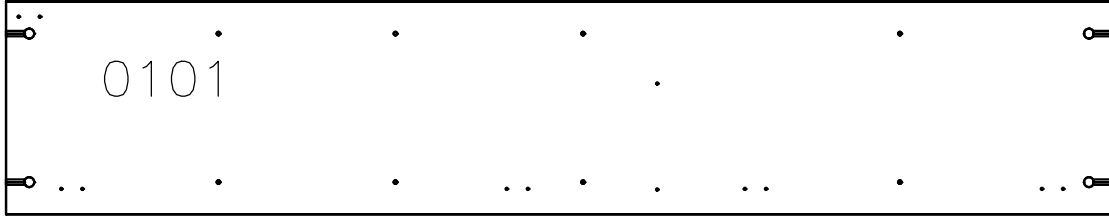

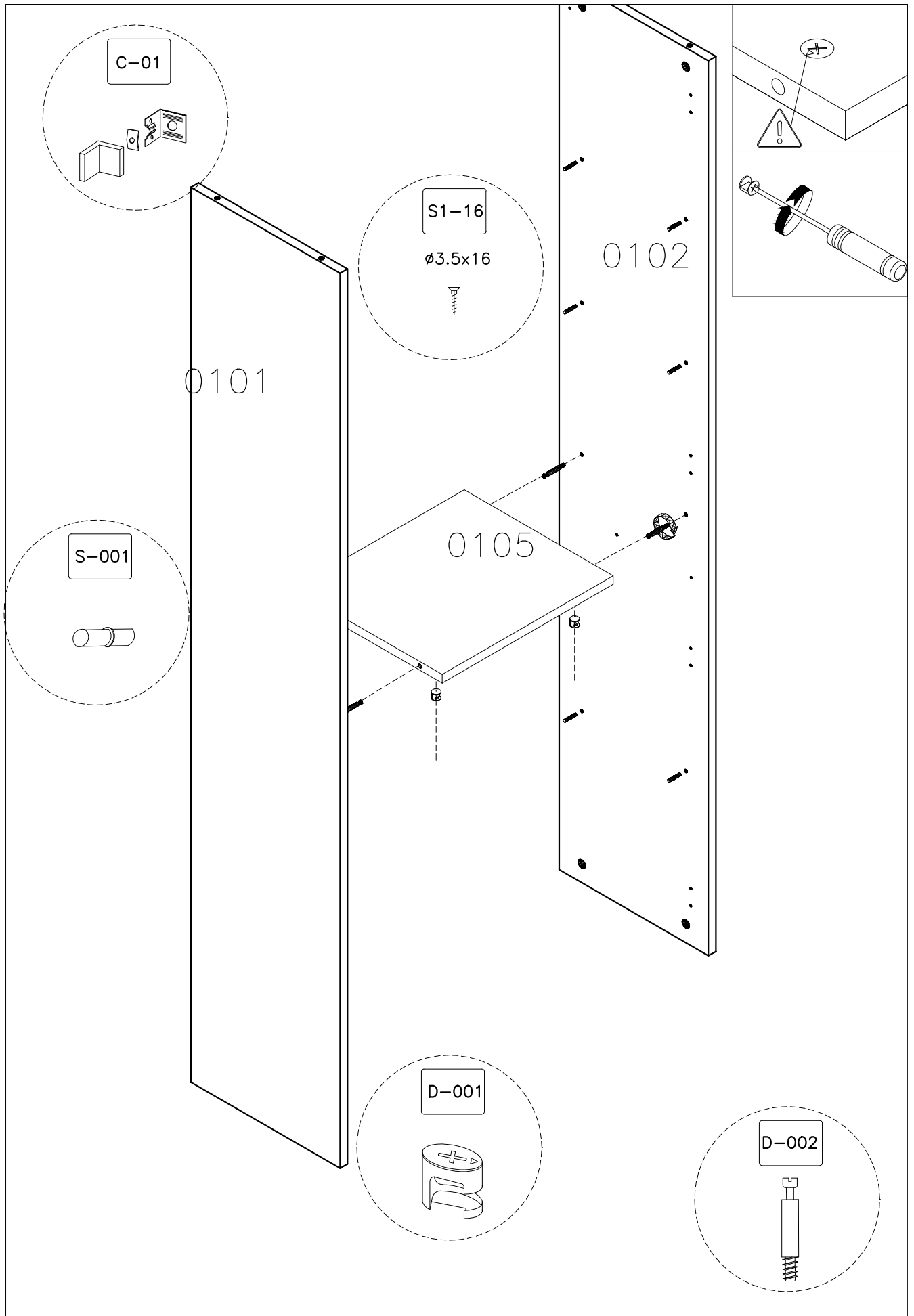

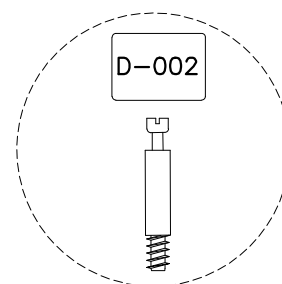
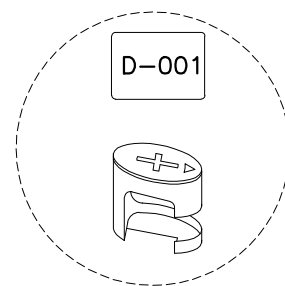
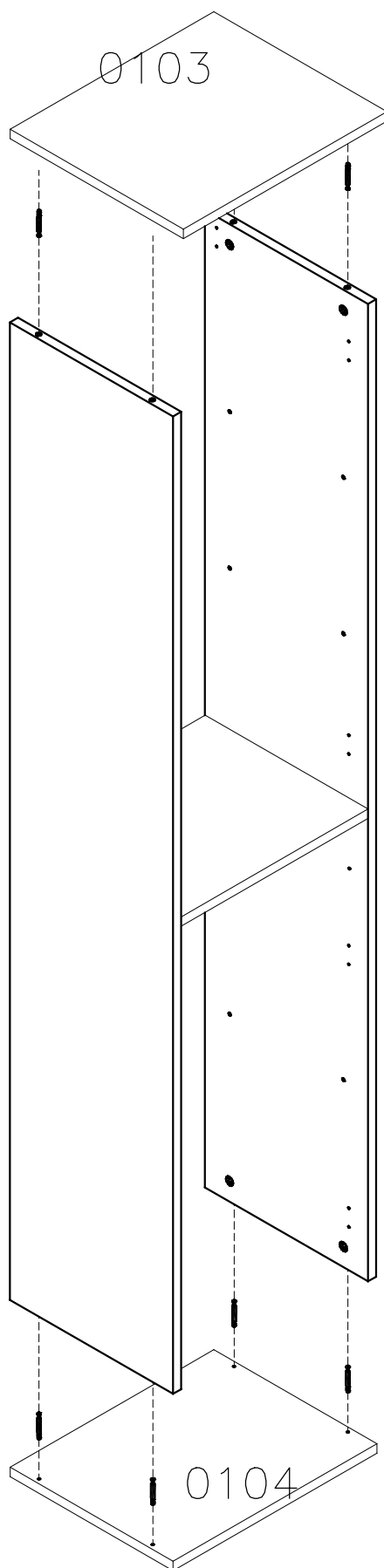
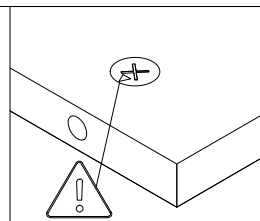
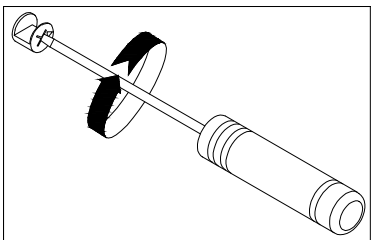

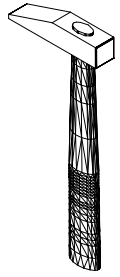

1695*395*3

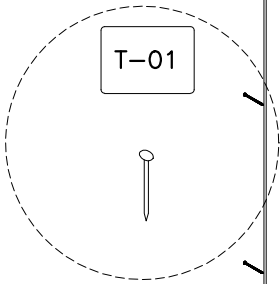

T-01

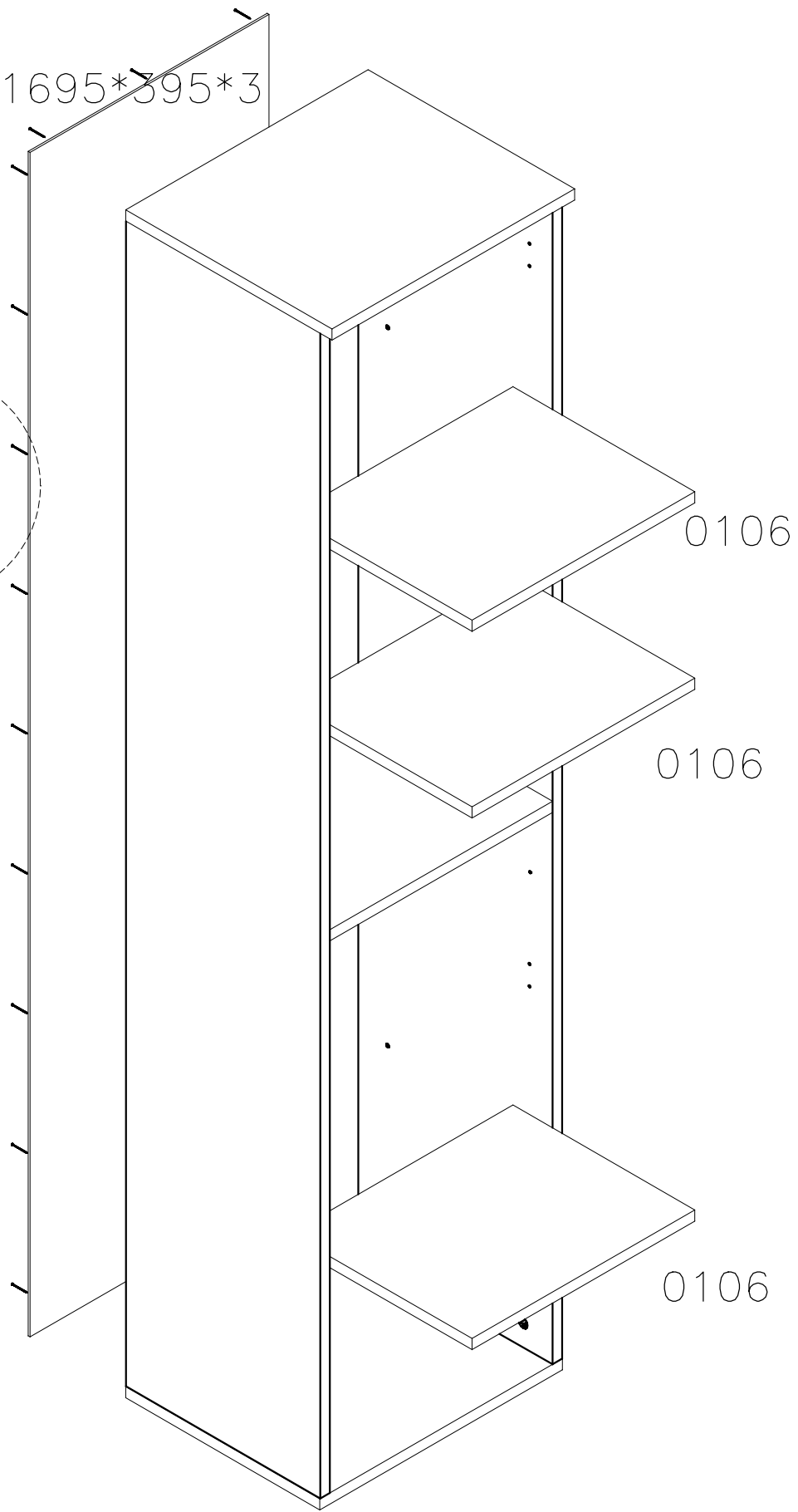

0106

0106

0106

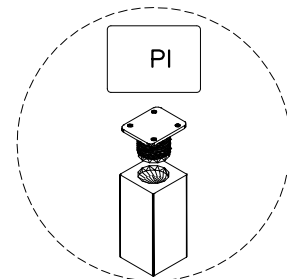
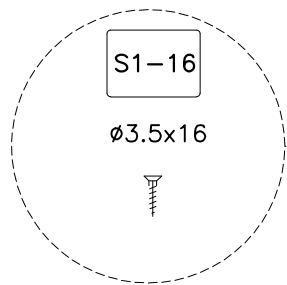
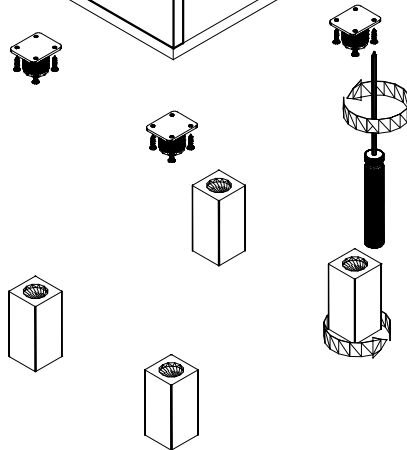
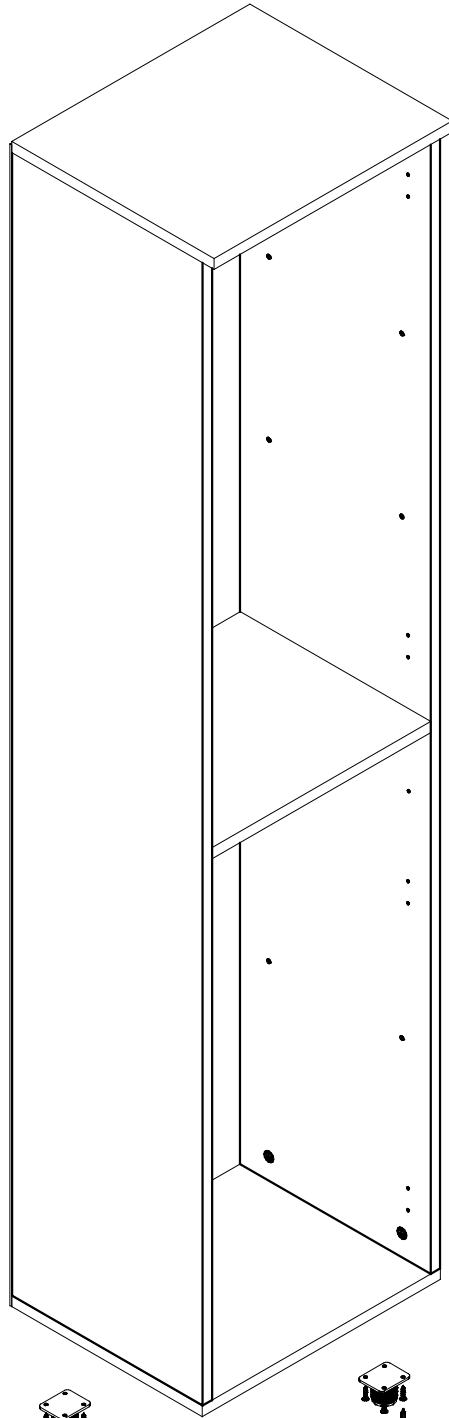

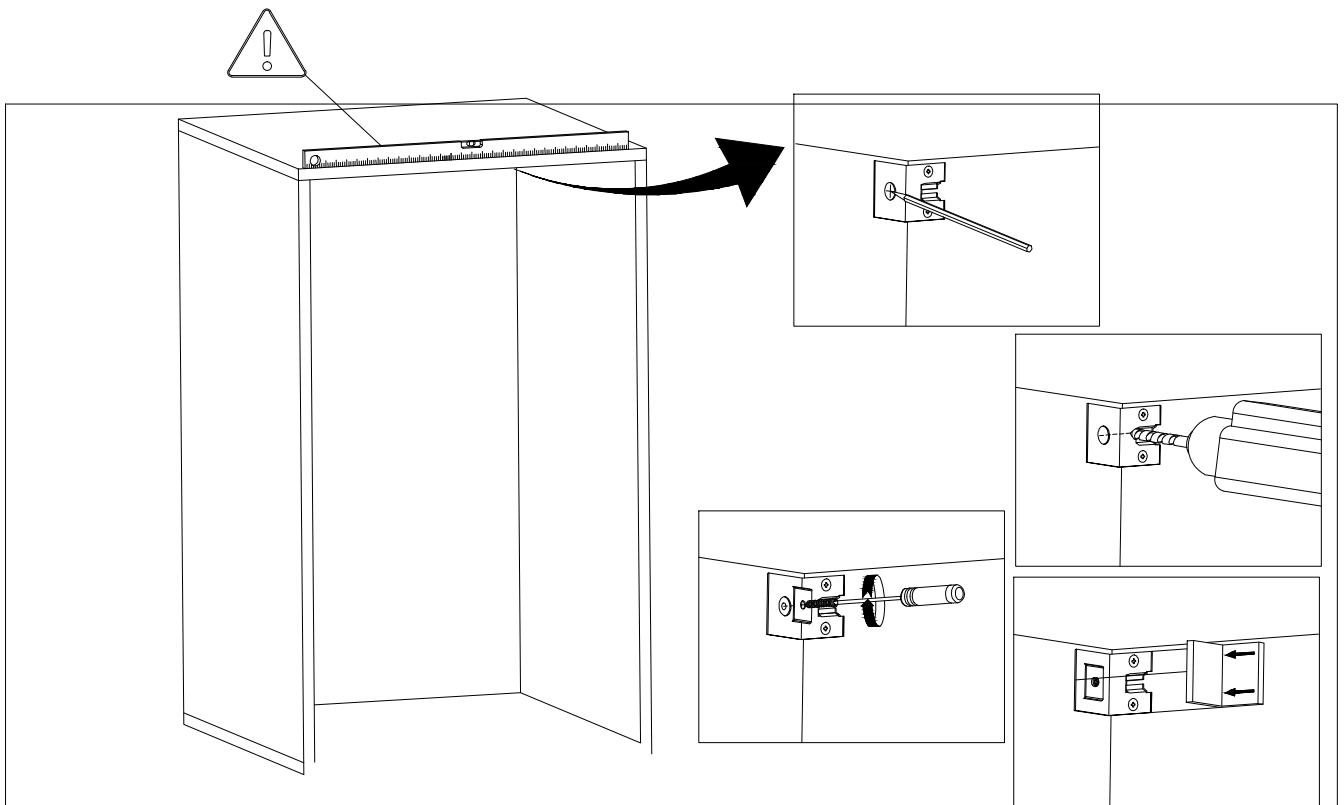
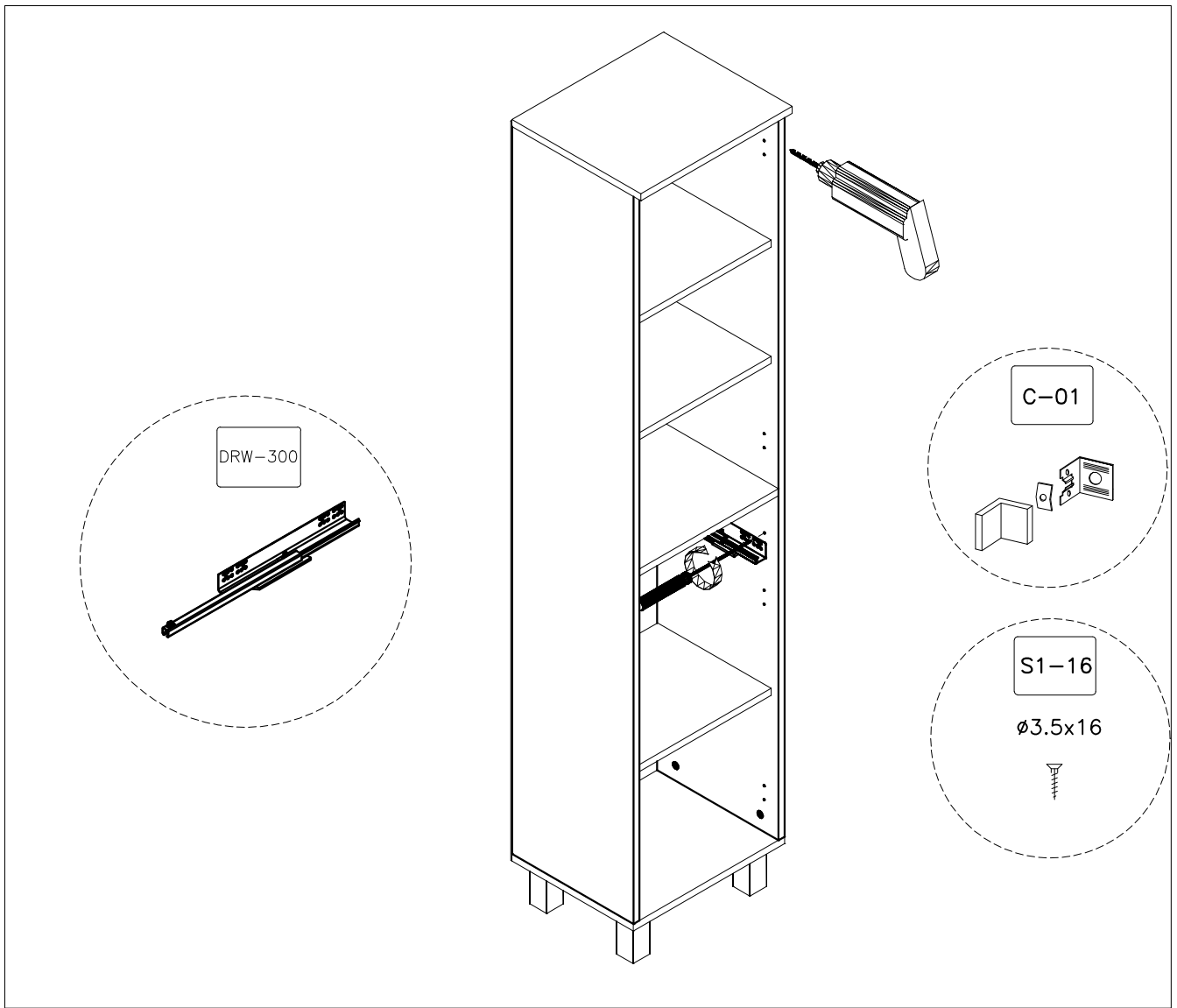

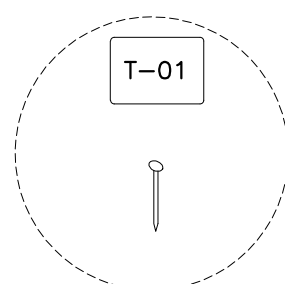
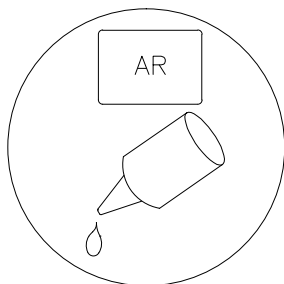
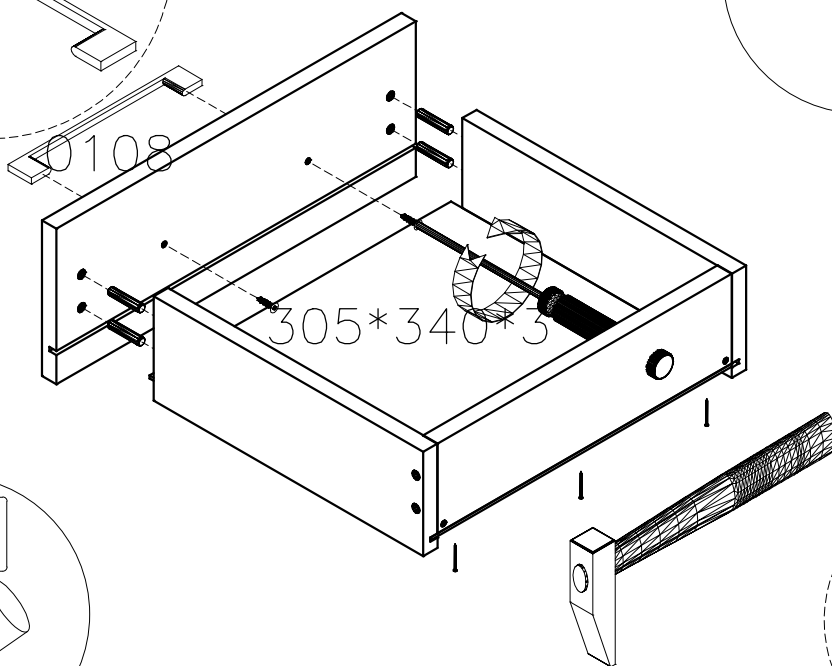
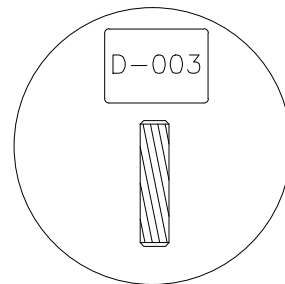
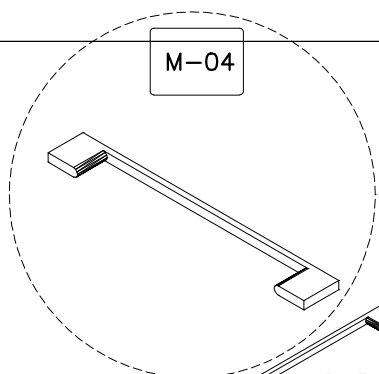
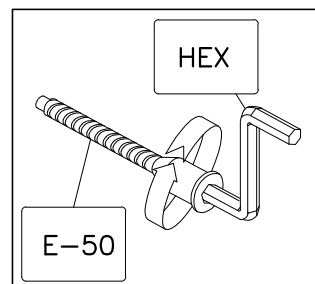
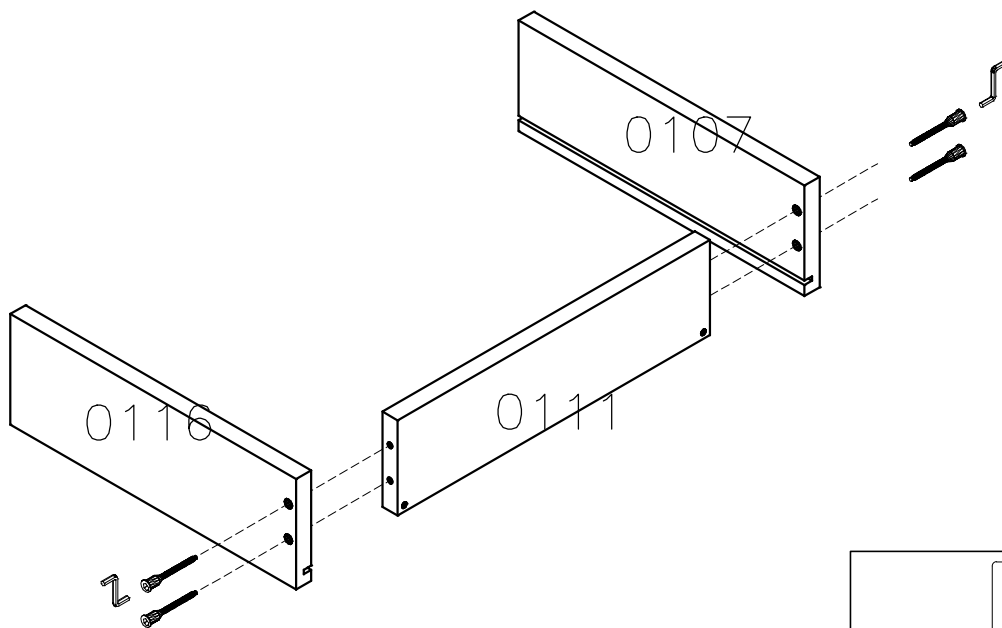

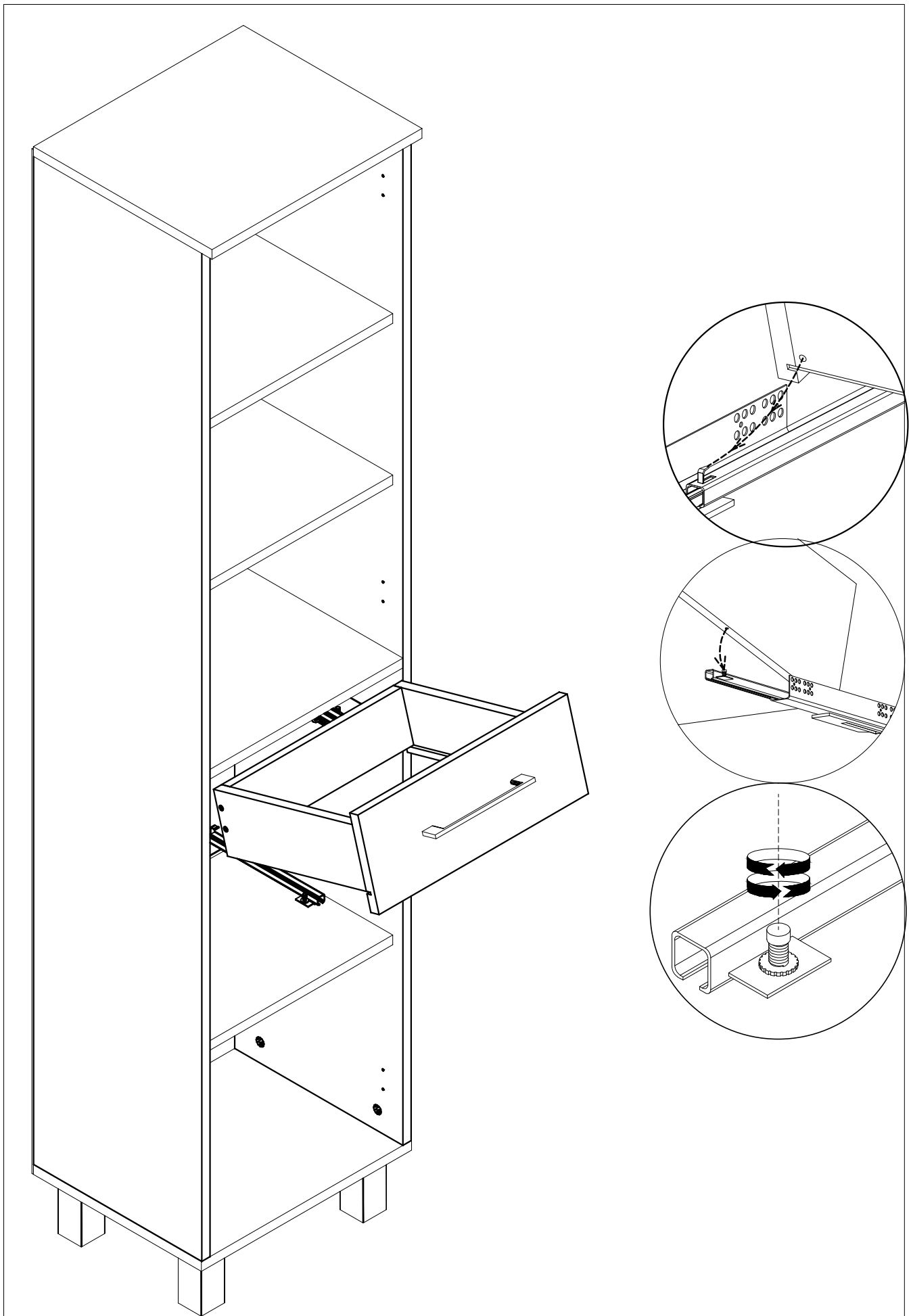

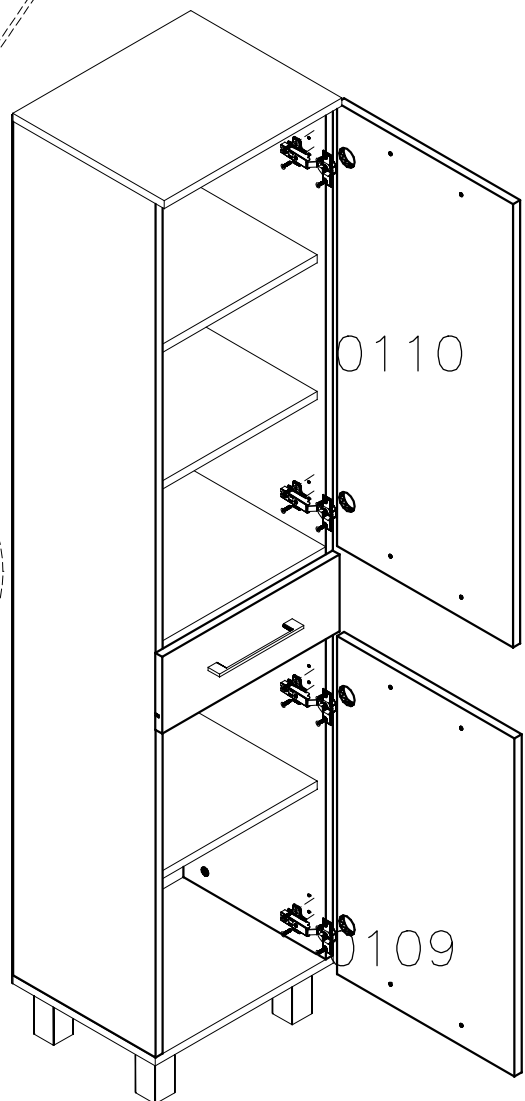
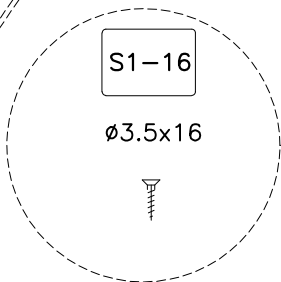
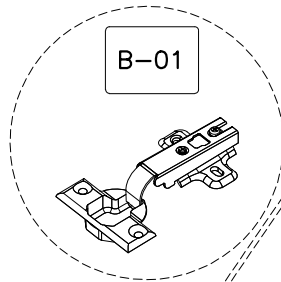
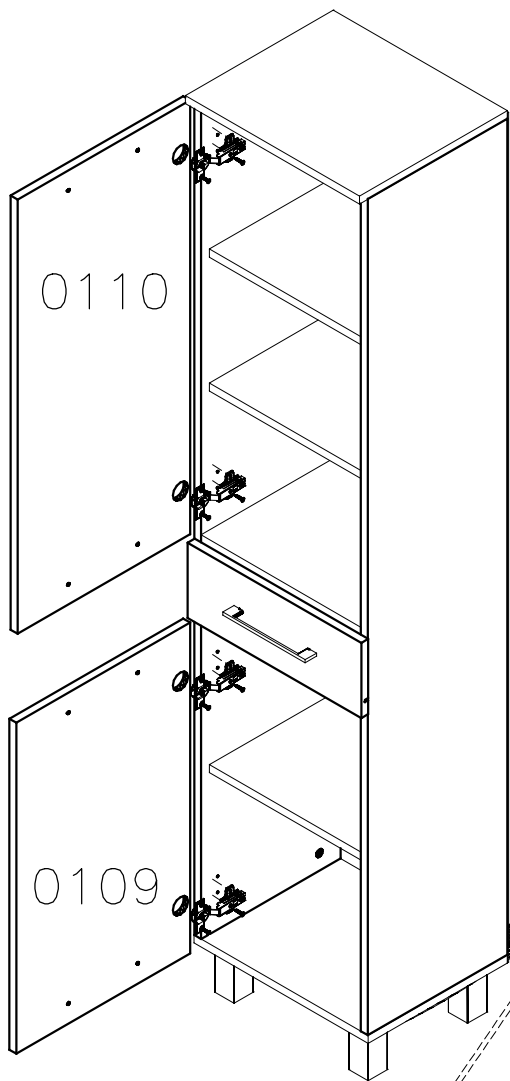

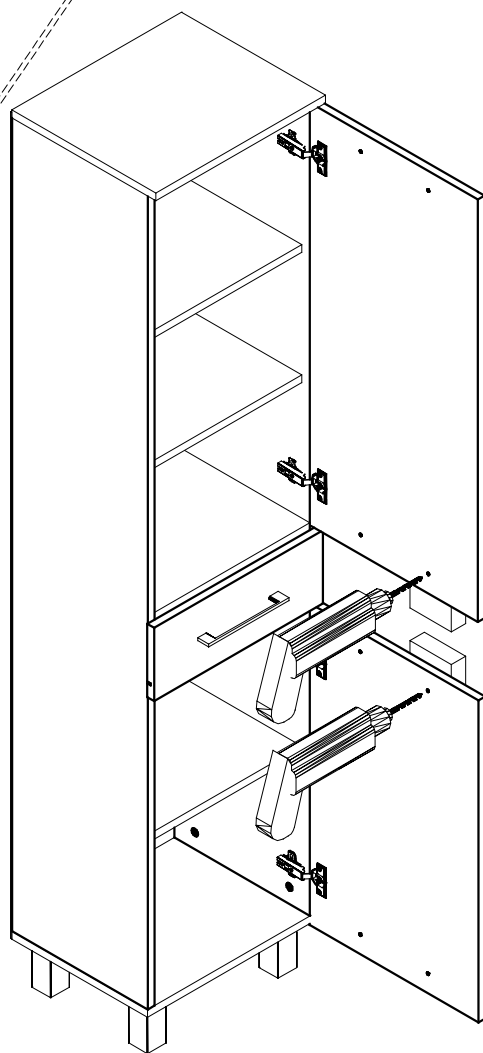
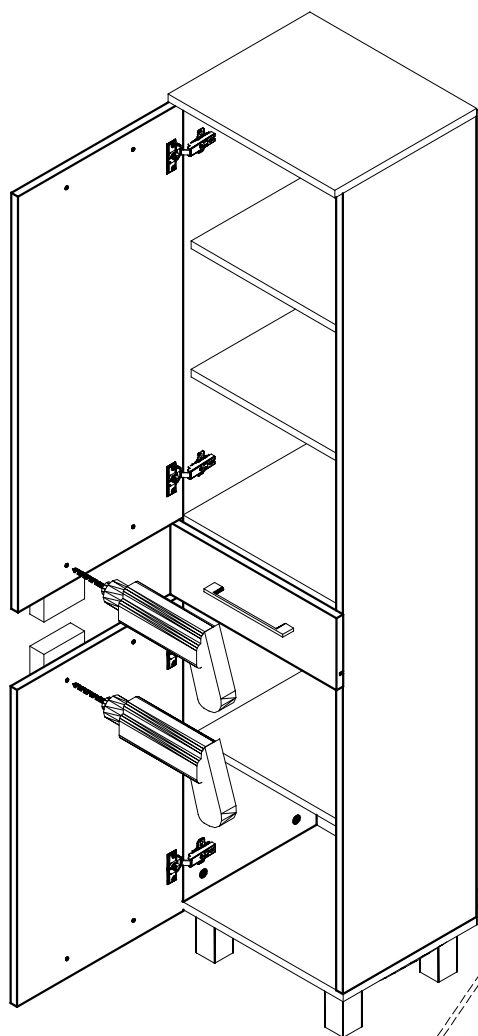

Ø 5 mm

