















PARTS LIST

Name	Part	Qty	Name	part	Qty
A Castor		5	H back frame		1
B base		1	I finishing cover		1
C gas lift		1	J screw M8x30mm		12
D seat and mechanism		1	K shim 8x22x1.5mm		12
E arm rest		2	L spanner 5mm		1
			M spanner 4mm		1
F back		1	O spanner 3mm		1
G main lumbar frame		1	N head rest		1



item no.:W-80

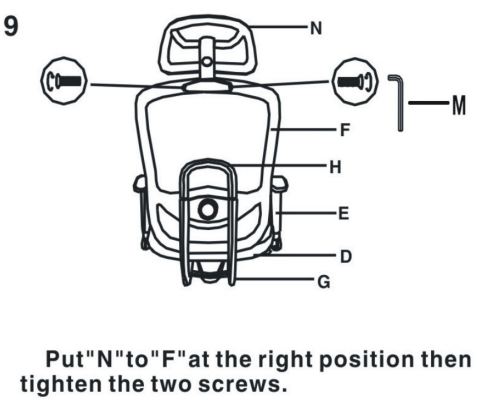
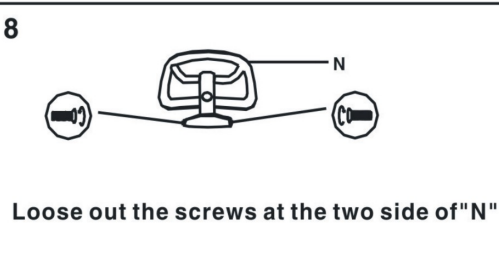
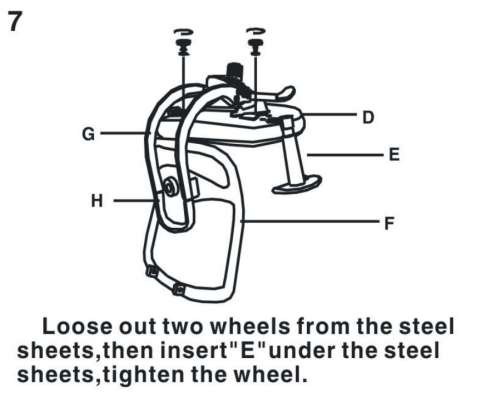
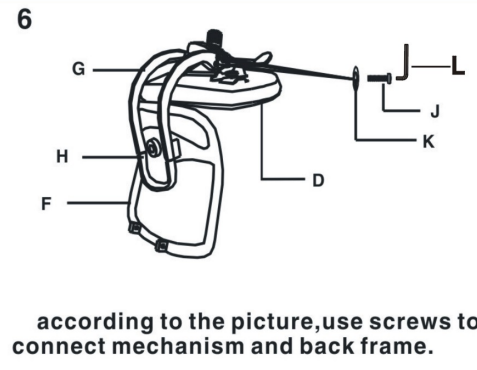
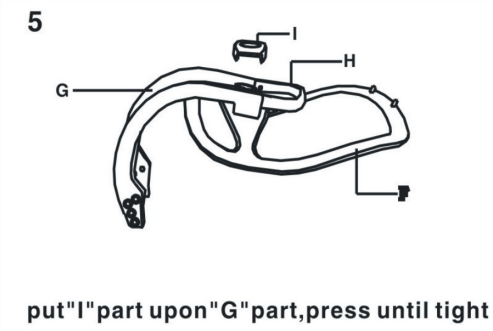
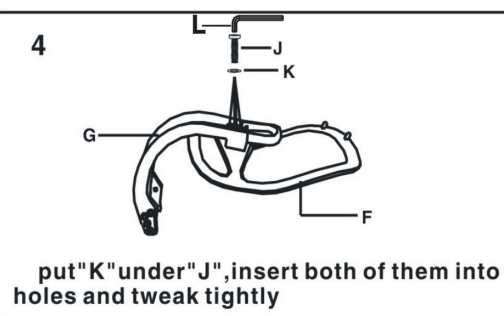
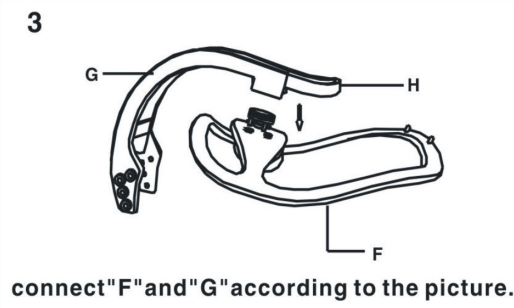
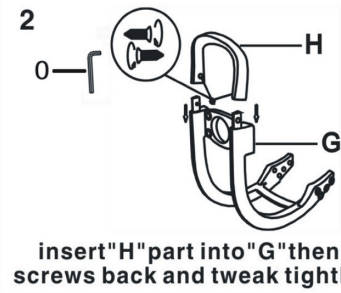
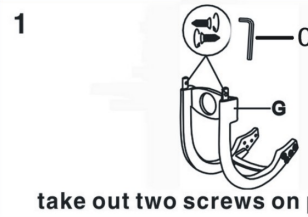
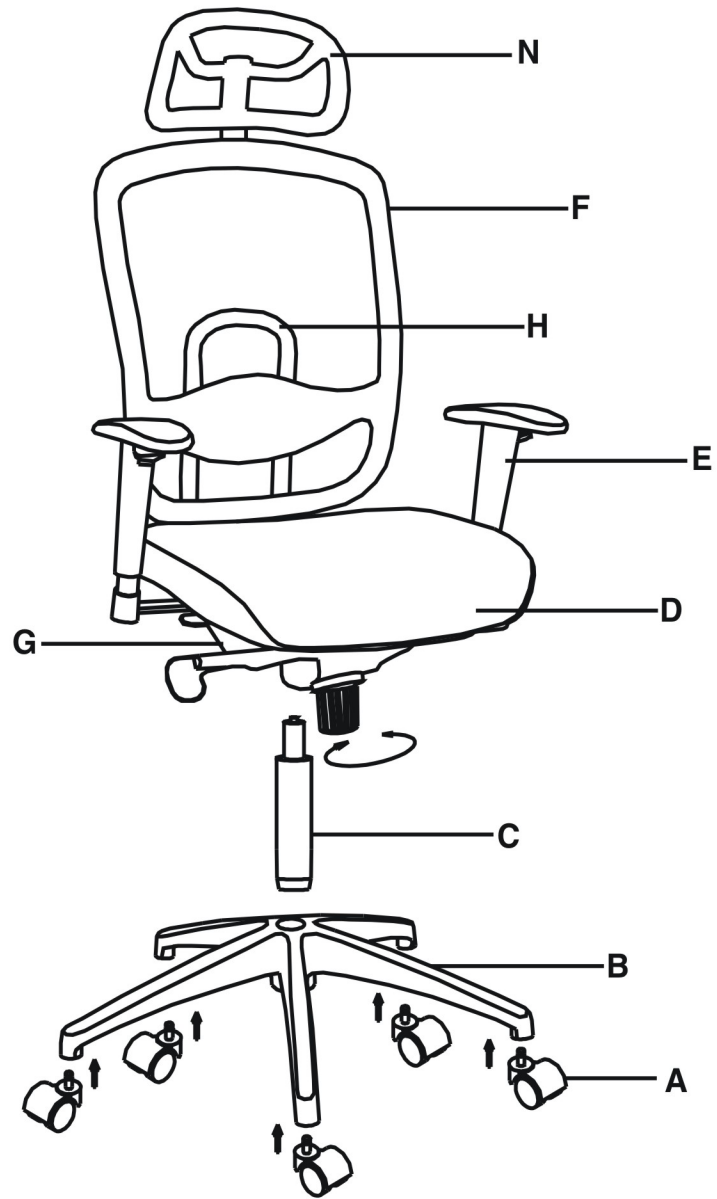

- 1.finish whole chair as this picture.
- 2.adjust the handle in mechanism base on your weight.

