

S.C. DEDEMAN S.R.L. BACAU
FABRICA DE MOBILA

CABINET "RUBIN"
Etajera mica, 750 x 400 x 1170 mm

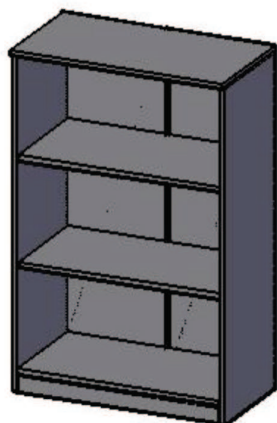







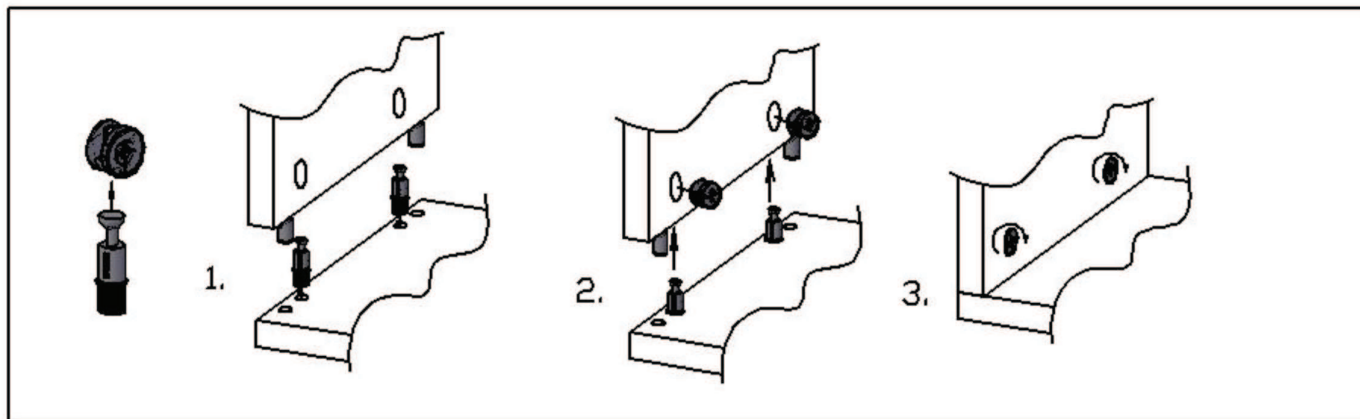
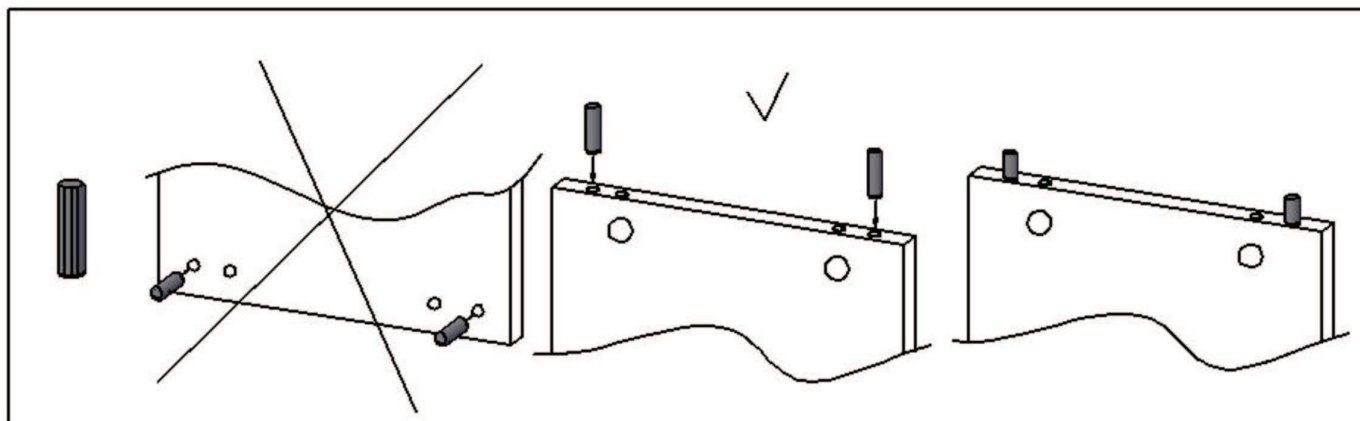

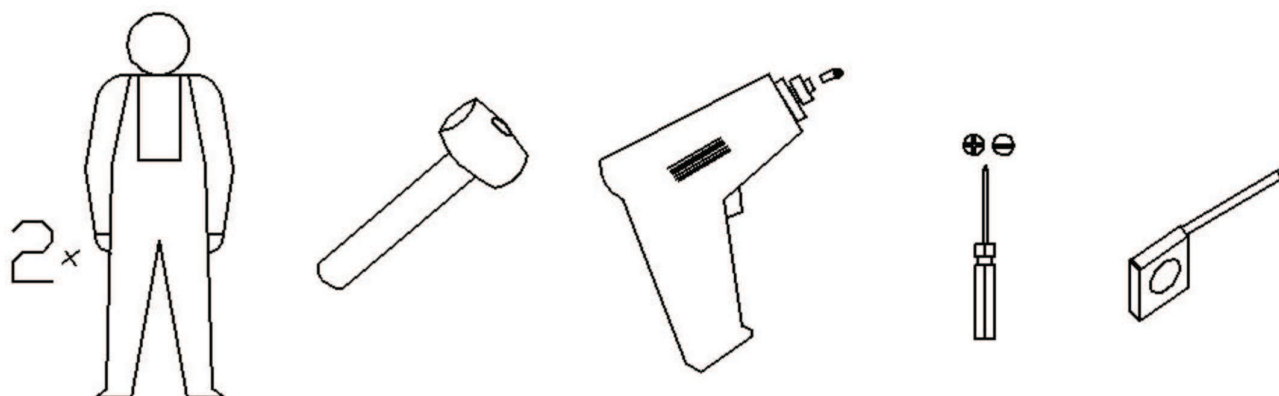

LISTA DE REPERE:

1. Tavan	750 x 400 mm	1 buc.
2. Perete lateral stanga	1150 x 380 mm	1 buc.
3. Perete lateral dreapta	1150 x 380 mm	1 buc.
4. Fund	716 x 380 mm	1 buc.
5. Chinga	716 x 60 mm	1 buc.
6. Polite mobile	716 x 375 mm	2 buc.
7. Spate PFL		2 buc.
22. Profil H pentru Imbinare spate PFL		1 buc.

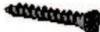
Instructiuni de montaj





REPER NR.:	DESCRIERE:	NR. BUCATI
001	 tija ansamblului demontabil	8
002	 cama cu excentric al ansamblului demontabil	8
020	 surub pentru lemn, 3,5 x 20 mm	8
007	 surub pentru lemn, 2,5 x 25 mm	35
011	 capac mascare din plastic	8
013	 suport polita metalic	12
014	 cep din lemn	18
019	 talpa plata	4
022	 profil H pentru spate PFL	1

Etape de montaj:

* Se identifica piesele componente.

1. Pe peretii laterali 2 si 3 (sunt in oglinda), se fixeaza tijele demontabililor- 001, si suportii de polita, 013. Tijele demontabililor, 001, se fixeaza si pe piesa 1, tavan, conform desenului, in gaurile care corespund cu gaurile pentru camele 002, de pe fetele peretilor.

2. Cepii din lemn - 014, se fixeaza la capetele superioare ale peretilor 2 si 3, in gaurile laterale si in cea de mijloc (conform schitei), si in gaurile piesei 5.

3. Se asambleaza peretii laterali 2 si 3 cu fundul 4 si chinga 5. Acest lucru se realizeaza prin rigidizarea cuplului tija - cama, rotind cama 002 cu o surubelnita in sensul acelor de ceasornic.

La acest ansamblu, se ataseaza tavanul 1, si se rigidizeaza, la fel, introducand cama 002 in gaurile specificate pe desen.

4. Spatele PFL 7, se asambleaza cu ajutorul profilului H, 22, se pozitioneaza si se prinde cu suruburile 2,5 x 25, 007. Distanța dintre suruburi trebuie sa fie de cca. 15 cm.