



THEA 50/ 75

KITCHEN HOOD

HOTA DE BUCATARIE

DUNSTABZUGSHAUBE

EXTRACTORA DE COCINA

HOTTE DE CUISINE

CAPPA DA CUCINA



Instruction manual EN RO DE ES FR IT

www.turbionaire.com

SAFETY INSTRUCTIONS

- Thank you for purchasing this cooker hood. Please read the instruction manual carefully before you use the cooker hood, and keep it in a safe place.
- The installation work must be carried out by a qualified electrician or competent person. Before you use the cooker hood, make sure that the voltage (V) and the frequency (Hz) indicated on the cooker hood are exactly the same as the voltage (V) and the frequency (Hz) in your home.
- The manufacturer and the agent will not bear any responsibility for the damage caused by inappropriate installation and usage.
- Never let children operate the cooker hood.
- The cooker hood is for home use only. It is not suitable for barbecues, Roast shop and commercial purposes.
- The cooker hood and its filter mesh should be cleaned regularly in order to keep it in good working order.
- Before cleaning, switch the power off at the main supply.
- Clean the cooker hood according to the instruction manual and keep the cooker hood from the danger of burning.
- Prohibit putting the cooker hood by fire.
- If there is any fault with the appliance, please call the service department to request a service engineer.
- This appliance can be used by children aged from 8 years and above and persons with reduced physical, sensory or mental capabilities or lack of experience and knowledge if they have been given supervision or instruction concerning use of the appliance in a safe way and understand the hazards involved. Children shall not play with the appliance. Cleaning and user maintenance shall not be made by children without supervision.
- If the supply cord is damaged, it must be replaced by the manufacturer, its service agent or similarly qualified persons in order to avoid a hazard.
- The instructions shall state the substance of the following: there shall be adequate ventilation of the room when the range hood is used at the same time as appliances burning gas or other fuels (not applicable to appliances that only discharge the air back into the room).
- Do not flambé under the range hood. Accessible parts may become hot when used with cooking appliances.

Important Hints on Installation

- The air must not be discharged into a flue that is used for exhausting fumes from appliances burning gas or other fuels (not applicable to appliances that only discharge the air back into the room).
- Regulations concerning the discharge of air have to be fulfilled.

Important notes about the extraction mode



WARNING

Risk of poisoning from exhaust gases sucked back. Never operate the device in extraction mode simultaneously with an open flue appliance when there is not adequate airflow guaranteed.

Open flue combustion equipment (for example, gas, oil, wood or coal-fired heaters, tankless water heaters, water heaters) pulls combustion air from the room and runs it through an exhaust pipe or chimney to the outside. In the extraction mode, indoor air is removed from the kitchen and the adjacent rooms - without sufficient air intake this creates a vacuum. Toxic gases from the chimney or extraction flue can thereby be sucked back into the living spaces.

- Always ensure that a sufficient supply of fresh air is guaranteed and that the air can circulate.
- An air supply / extractor box alone does not ensure compliance with the limit value.

Safe operation is only possible when the negative pressure in the room where the appliance is located does not exceed 4 Pa (0.04 mbar). This can be achieved when the air required for combustion can flow through openings that are not closable, for example in doors, windows, in conjunction with an air supply/ extractor box or through other technical measures. In any case, consult a qualified chimney sweep who can assess the entire ventilation of your house and propose appropriate measures for adequate ventilation.

If the hood is used exclusively in the recirculation mode, unrestricted operation is possible.



WARNING

Fire hazard from flying sparks. Only install equipment on a fire place for solid fuels (for example, wood or coal), if a closed, non-removable cover is available.

DIMENSIONS

Model No.: THEA - Product Code TH50RCB, TH50RC

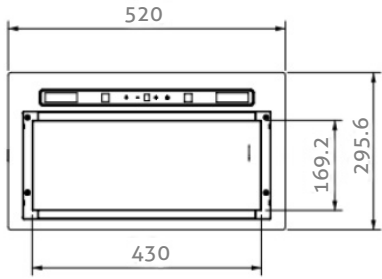
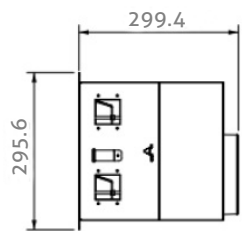
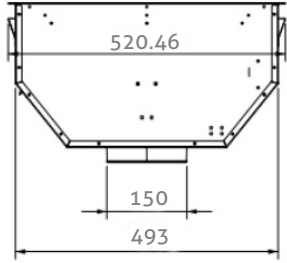
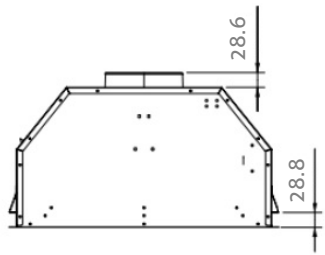

DIMENSIONS

THEA 75 - Product Code TH75RCB, TH75RC

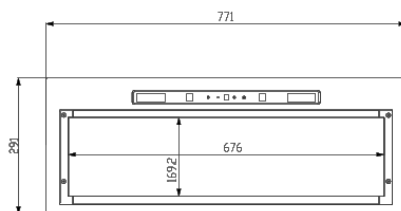
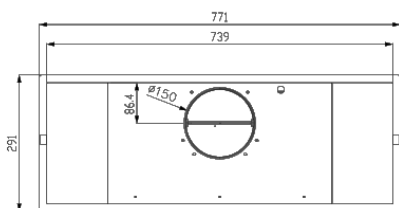
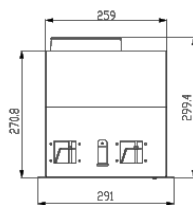
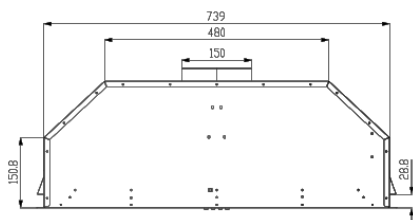

INSTALLATION

Note: When the range hood and appliance supplied with energy other than electricity are simultaneously in operation, the negative pressure in the room must be not exceed 4 Pa (4 x 10⁻⁵ Bar).

Required **minimum distance hood to**

Ceramic-glass rings/hotplates	65 cm
Gas cooker	75 cm
Coal / oil / stove wood firing	85 cm

Installation Steps

Note: Do not connect the power cable until the installation is complete! Get a second person to help you with the installation.

1.Saw an opening in the wall cabinet under which the hood is to be fitted. Use the following dimensions (mm) as a guide:

HOLE MEASUREMENTS FOR INSTALLATION (mm)

Image 1.

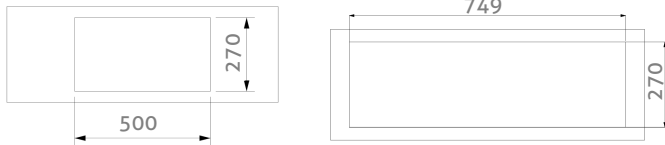

THEA 50

THEA 75

2. Insert the range hood into the cabinet. Please make sure the elastic pins of the both sides are fixed on the cabinet.

Image 2.

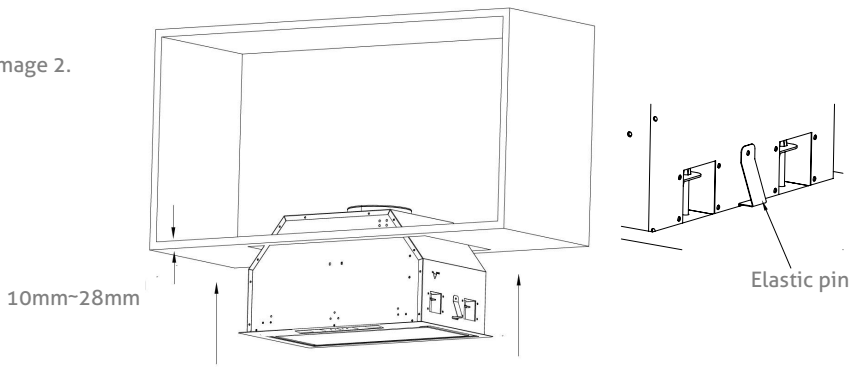

10mm-28mm

Elastic pin

3. Remove the metal grease filter

Image 3.

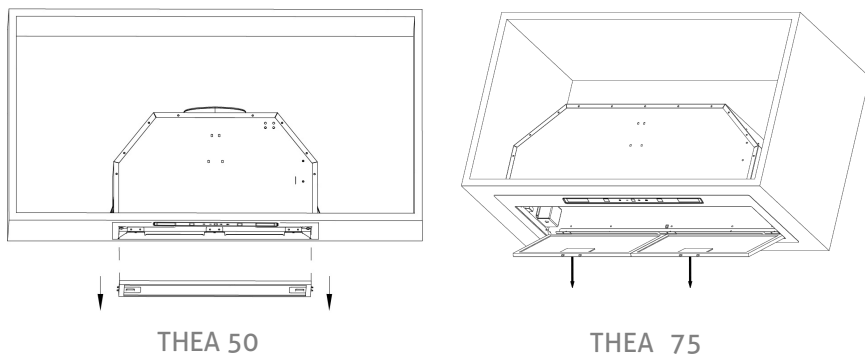

4. Adjust the screws 1. 2 .3 .4 . until the flanges of the both sides are fixed on the cabinet as the Image 5

Image 4.

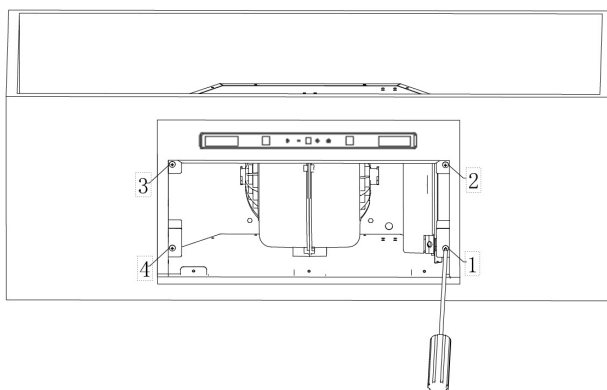
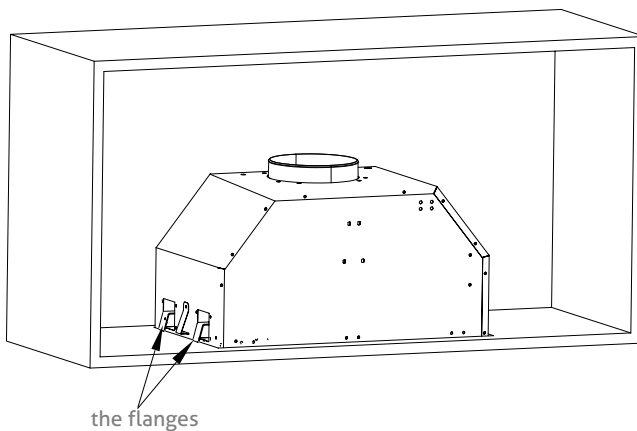
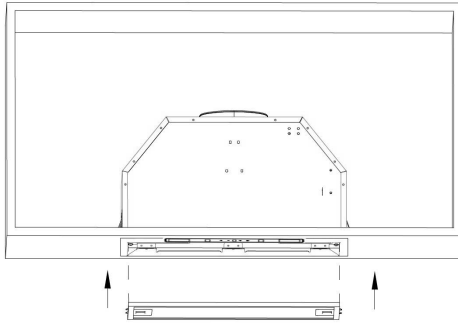

Image 5.



5.Reinstall the metal grease filter (Image 6), and complete the installation (Image 7)

Image 6.



THEA 50

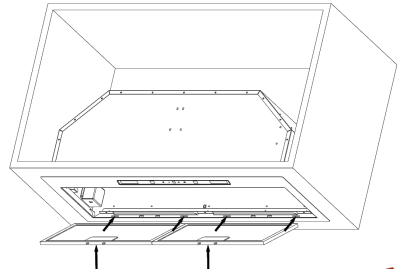

THEA 75

Image 7.

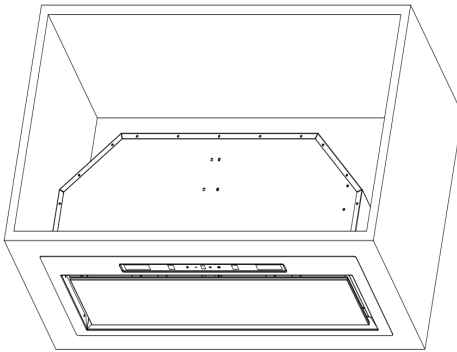

6.The size (mm) of the duct.

THEA - Product Code TH50RCB, TH50RC

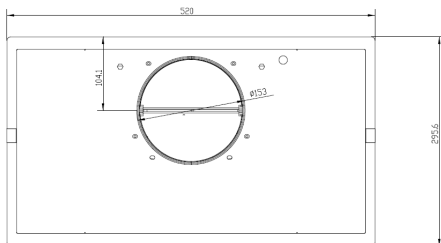

THEA 75 - Product Code TH75RCB, TH75RC

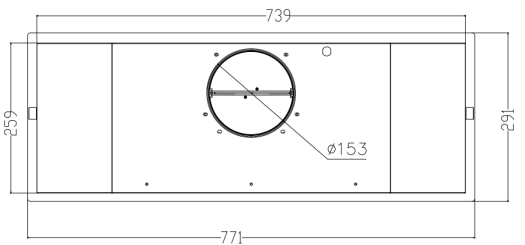

7. Installation of check valve (Image 8), suction pipe, (Image 9) and electrical connection (Image 10)

Model No.: THEA 50 - Product Code TH50RCB, TH50RC

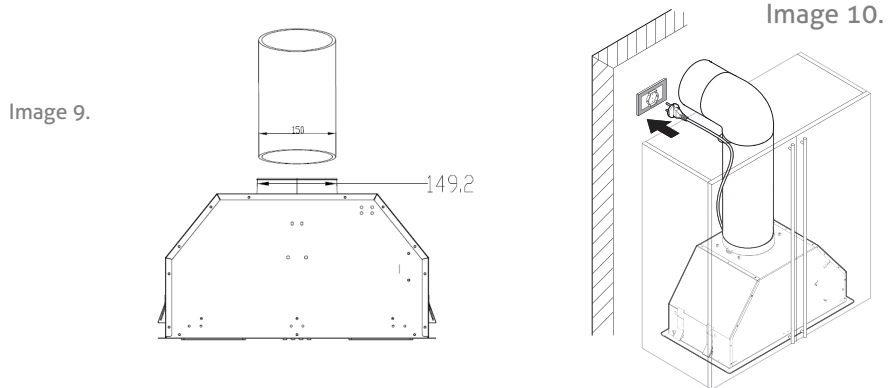
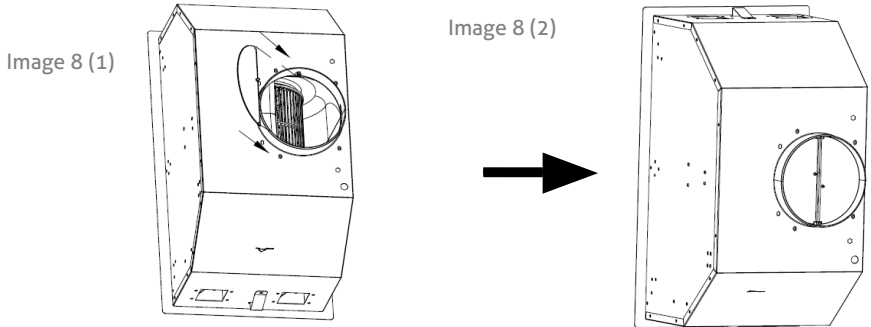

8. Installation of the duct adaptor

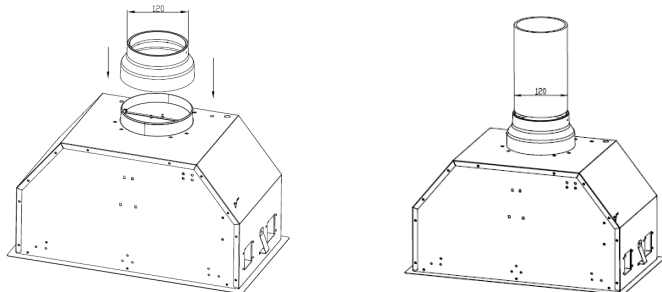

9. Installation of the carbon filter - **CODE: TCF1** (not included)

Model No.: THEA 50/ 50 BLACK - product Code TH50RCB, TH50RC

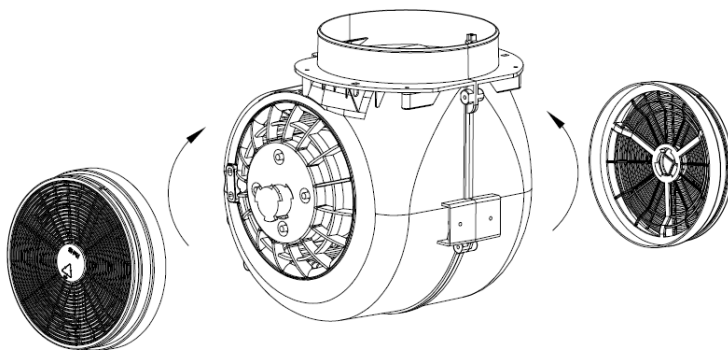

THEA - Product Code TH50RCB, TH50RC

Technical data

	Value	Unit
Motor capacity	800	m ³ /h
Maximum cooker hood airflow - boost	607	m ³ /h
Cooker hood airflow at working point - high	542	m ³ /h
Cooker hood airflow at working point - low	344	m ³ /h
Electric power input	124	W
Nominal power of the lighting system	4	W
Sound power level - boost	67	dB
Sound power level - high	65	dB
Sound power level - low	55	dB
Energy Efficiency class	A+	
Annual Energy Consumption	23.4	kWh/a
Connection diameter - Minimum/ Optimum	120/150	mm

THEA 75 - Product Code TH75RCB, TH75RC

Technical data

	Value	Unit
Motor capacity	800	m ³ /h
Maximum air flow - Boost	692	m ³ /h
Cooker hood airflow at working point - high	613	m ³ /h
Cooker hood airflow at working point - low	313	m ³ /h
Electric power input	125	W
Nominal power of the lighting system	5	W
Sound power level - boost	66	dB
Sound power level - high	65	dB
Sound power level - low	50	dB
Energy Efficiency class	A++	
Annual Energy Consumption	27.2	kWh/a
Connection diameter - Minimum/ Optimum	120/150	mm

THEA 50/ 75 - FUNCTIONS

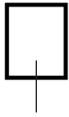

Gesture sensor



Display screen

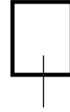

Gesture sensor



ON/ OFF Key - turning ON/ OFF the Fan



Speed plus key - For increasing the speed of the fan. Long press this icon for booster setting, will go back to high speed after operating for 5 minutes.



Speed decrease key - For decreasing the speed of the fan.



Light Key - turning ON/ OFF the light





Digital Display - Fan speed display:

"1" f or Low speed, "2" f or Medium speed, "3" for High speed, "B" for Booster speed, "C" for air cleaning function.



Quick timer: Press **+** & **-** simultaneously for 1 second. The digital display flashes & the countdown starts for 5 minutes. After 5 minutes, the motor & the light will turn off automatically & the Buzzer sound will keep buzzing for 5 seconds if there is no other operations, the buzzer sound can be stopped by depressing any button during the buzzing. If need to stop this function during the countdown, press **+** & **-** simultaneously for 1 second again.

Air cleaning function

In standby state, long press the  key for 3 seconds to enter the air cleaning function. This function automatically shuts down after 5 minutes of low speed operation. After 55 minutes of stop, it automatically runs again for 5 minutes and then stops again for 55 minutes.



"C" is displayed on the display screen during low speed operation. After this function is started, it can only be turned off by pressing the on key again for 1 second, without affecting other normal switch operations (the  key blinks when entering the air cleaning function).

How to match the remote control

In standby state, long press the  button for 3 seconds to enter the remote control matching state, and the indicator light keeps flashing. In the matching state, press the remote control  button and a beep sound will be heard, the remote is successfully matched. If no operation is performed or the match fails after 15 seconds, the system returns to the standby state.



How to use the remote control

-  **ON/ OFF Key** - used for turning on/off the fan.
- +** **Speed plus key** - For increasing the speed of the fan; Long press this icon for Booster setting, will go back to high speed after operating for 5 minutes.
- **Speed decrease key** - For decreasing the speed of the fan.
-  **Light key** - used for turning on/off the light



Gesture control

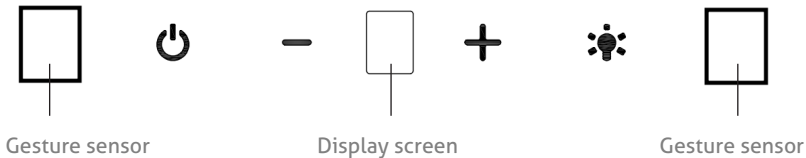

This function is available if the unit is in standby mode.

Motion sensors are activated by passing the hand from left to right or vice versa through the control panel.

1. Moving the hand from left to right increases the speed level. From boost mode, the same movement causes the return to minimum speed.
2. Passing the hand from right to left, a function available only when the unit's motor is on, causes it to enter **Quick Timer** mode, after which it will stop after 5 minutes. From the Quick Timer mode, the same movement causes the unit to stop immediately.

The speed level set as a result of the gesture control will be permanently displayed on the display. In Quick Timer mode, the speed level will be displayed intermittently.

STAINLESS STEEL SURFACES CLEANING

To avoid damaging the stainless steel surface of your appliance

Always clean with:

Soft cloths, distilled or filtered water, as well as detergents specially made for stainless steel.

Do not clean with:

Abrasive materials, cleaning powders, bleach and other chlorine-based products, ammonia-containing glass cleaners, tap water especially if it tends to be hard water, oven cleaners.

Damage to stainless steel surfaces due to the use of improper cleaning substances is not covered by the warranty.

TROUBLESHOOTING

Fault	Cause	Solution
Light on, but fan does not work	The fan blade is jammed.	Switch of the unit and repair by qualified service personnel only.
	The motor is damaged.	
Both light and fan do not work	light bulb burn.	Replace the bulb with correct rating.
	Power cord looses.	Plug in to the power supply again.
Serious Vibration of the unit	The fan blade is damaged.	Switch of the unit and repair by qualified service personnel only.
	The fan motor is not fixed tightly.	
	The unit is not hung properly on the bracket.	Take down the unit and check whether the bracket is in proper location.
Suction performance not good	Too long distance between the unit and the cooking plane	Readjust the distance to 65-75cm

HINTS ON DISPOSAL



According to the European waste regulation 2012/19/EU this symbol on the product or on its packaging indicates that this product may not be treated as household waste. Instead it should be taken to the appropriate collection point for the recycling of electrical and electronic equipment. By ensuring this product is disposed of correctly, you will help prevent potential negative consequences for the environment and human health, which could otherwise be caused by inappropriate waste handling of this product. For more detailed information about recycling of this product, please contact your local council or your household waste disposal service.

Manufacturer

Intax Trading SRL
14B Ion Creanga Str., 075100, Otopeni, Ilfov, Romania
office@intaxtrading.com
www.intaxtrading.com

INSTRUCȚIUNI DE SIGURANȚĂ

- Vă mulțumim pentru achiziționarea acestei hote de aragaz. Citiți cu atenție manualul de instrucțiuni înainte de a utiliza hota și păstrați-l într-un loc sigur.
- Instalarea trebuie să fie efectuată de un electrician calificat sau de o persoană competentă. Înainte de a utiliza hota, asigurați-vă că tensiunea electrică (V) și frecvența (Hz) indicate pe hotă sunt exact aceleași cu tensiunea electrică (V) și frecvența (Hz) din casa dumneavoastră.
- Producătorul și agentul nu sunt responsabili pentru daunele cauzate de instalarea și utilizarea neadecvată a hotei.
- Nu lăsați niciodată copiii să manipuleze hota.
- Hota este strict pentru uz casnic. Nu este potrivită pentru grătare, magazine fast food și în scopuri comerciale.
- Hota și filtrul acesteia trebuie să fie curățate în mod regulat pentru a o păstra în stare bună de funcționare.
- Înainte de a o curăța, opriți alimentarea de la sursa principală.
- Curățați hota în conformitate cu manualul de instrucțiuni și păstrați-o în afara pericolului de ardere.
- Este interzisă depozitarea hotei lângă sursă de foc.
- În cazul în care există orice defect al echipamentului, sunați departamentul de service pentru a solicita un inginer de service.
- Acest echipament poate fi utilizat de copiii cu vârsta de 8 ani sau peste și de persoanele cu capacități fizice, senzoriale și mentale reduse sau fără experiență și cunoștințe, dacă acestea au fost supravegheate sau instruite cu privire la utilizarea în siguranță a echipamentului și dacă înțeleg pericolele pe care le implică. Copiilor le este interzis să se joace cu echipamentul. Curățarea și întreținerea nu trebuie să fie realizate de copii fără supraveghere.
- În cazul în care cablul de alimentare este deteriorat, acesta trebuie să fie înlocuit de către producător, agentul de service al acestuia sau de alte asemenea persoane calificate pentru a evita o situație periculoasă.
- Instrucțiunile vor indica următoarele: va exista o ventilare adecvată a camerei atunci când hota este folosită în paralel cu echipamente pe gaz sau alți combustibili (nu se aplică echipamentelor care doar eliberează aerul înapoi în cameră)
- Nu flambați sub hotă. Părțile accesibile se pot încinge atunci când sunt folosite împreună cu aparate de gătit.

Indicații importante privind instalarea

- Aerul nu trebuie să fie evacuat pe un coș care este folosit pentru eliminarea gazelor care provin de la echipamentele cu ardere de gaz sau alți combustibili (nu se aplică echipamentelor care doar eliberează aerul înapoi în cameră).
- Reglementările privind eliminarea aerului trebuie să fie respectate.

Note importante despre modul de extragere



ATENȚIE

Risc de intoxicare cu gazele evacuate aspirate înapoi. Nu utilizați niciodată dispozitivul în modul de extracție simultan cu un echipament cu coș de tiraj deschis dacă nu este garantat un flux de aer adecvat.

Echipamentul deschis de combustie a gazelor arse (de exemplu gaz, ulei, lemn sau încălzitoarele pe bază de cărbune, încălzitoarele instantanee de apă, boilere) extrage aerul de combustie din cameră și îl duce printr-o conductă de evacuare sau printr-un coș de fum în exterior. În modul de extragere, aerul interior este îndepărtat din bucătărie și din încăperile adiacente – fără aer suficient acest lucru creează un vacuum. Gazele toxice din coșul de fum sau din coșul de tiraj pot, prin urmare, să fie din nou trase înapoi în spațiile de locuit.

- Asigurați-vă întotdeauna că este furnizat suficient aer proaspăt și că acesta poate circula.
- Doar o alimentare cu aer/cutie extractoare nu poate asigura conformitatea cu valoarea limită.

Operarea în siguranță este posibilă doar atunci când presiunea negativă din camera unde este localizat echipamentul nu depășește 4 Pa (0.04 mbari). Acest lucru poate fi obținut atunci când aerul necesar pentru combustie poate trece prin orificii care nu pot fi închise, de exemplu uși, ferestre, împreună cu o alimentare cu aer/cutie extractoare sau prin alte mijloace tehnice. În orice caz, consultați un coșar calificat care poate evalua întreaga ventilație a casei dumneavoastră și care poate propune măsuri corespunzătoare pentru o ventilație adecvată. În cazul în care hota este utilizată exclusiv în modul recirculare, este posibilă operarea fără restricții.



ATENȚIE

Pericol de incendiu de la scânteii. Instalați echipamentul pe un șemineu pentru combustibili solizi (de exemplu lemn sau cărbune) doar dacă este disponibil un capac închis, nedemontabil.

DIMENSIONI

Model No.: THEA 50 - Product Code TH50RCB, TH50RC

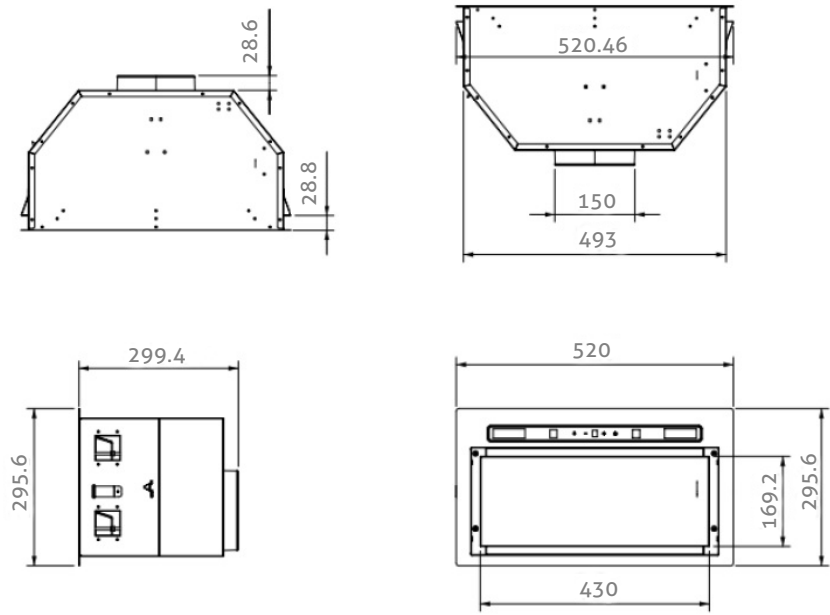

DIMENSIONI

Model No.: THEA 75 - Product Code TH75RCB, TH75RC

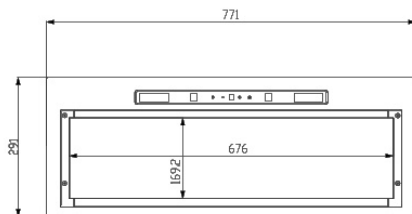
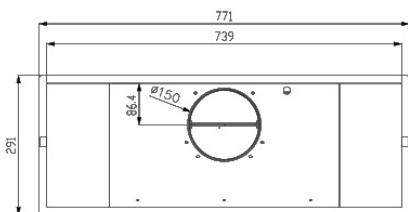
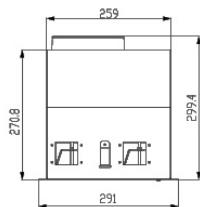
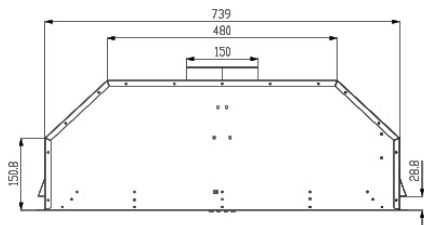

INSTALARE

Notă: Atunci când hota și echipamentul alimentat cu energie alta decât cea electrică funcționează simultan, presiunea negativă din încăperea nu trebuie să depășească 4 Pa (4 x 10-5 Bari).

Distanță minimă necesară a hotei față de

Inelele de sticlă ceramică/plite	65 cm
Aragaz pe gaz	75 cm
Foc plită cu lemne/cărbune/ulei	85 cm

PAȘII DE INSTALARE

Notă: Nu conectați cablul de alimentare până ce nu este finalizată instalarea! Chemați o a doua persoană care să vă ajute la instalare.

1. Tăiați un orificiu în peretele dulapului sub care va fi montată hota. Folosiți următoarele dimensiuni (mm) drept ghid:

DIMENSIUNI GOL INSTALARE (mm)

Imaginea 1.

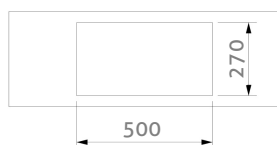

THEA 50

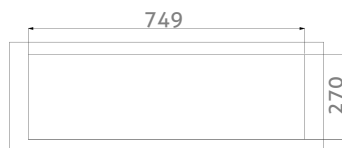

THEA 75

2. Inșerați hota în dulap. Asigurați-vă că pe dulap sunt fixate clemele elastice din ambele părți.

Imaginea 2

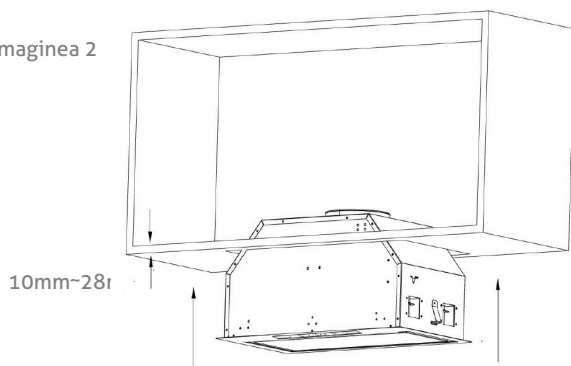

10mm-28mm

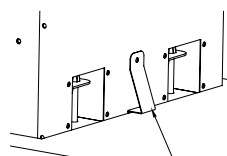

Clemă elastică

3. Îndepărtați filtrul metallic pentru grăsime.

Imaginea 3.

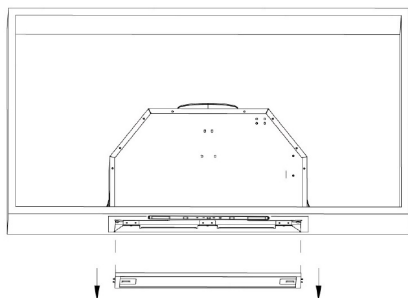

THEA 50

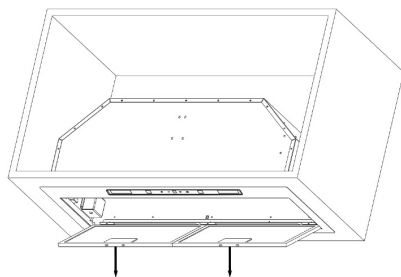

THEA 75

4. Reglați șuruburile 1. 2. 3. 4. până ce flanșele de pe ambele părți sunt fixate pe dulap ca în imaginea 5.

Imaginea 4.

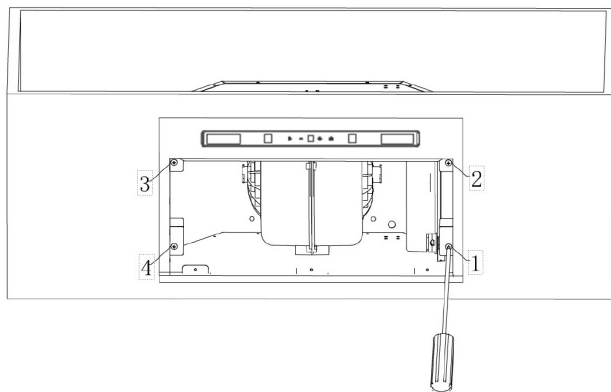

Imaginea 5.

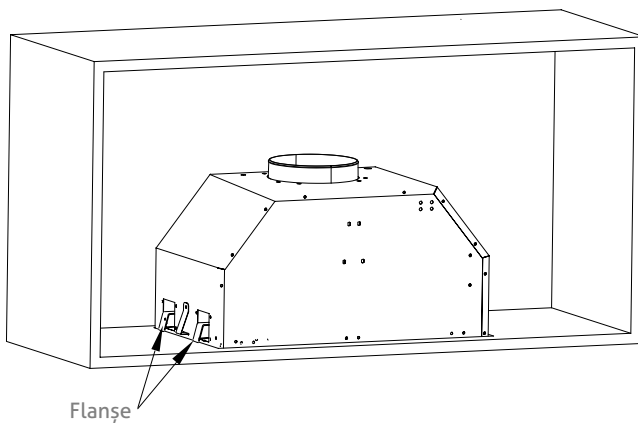

Flanșe

5. Reinstalați filtrul metallic de grăsime (imaginea 6) și finalizați instalarea (imaginea 7).

Imaginea 6.

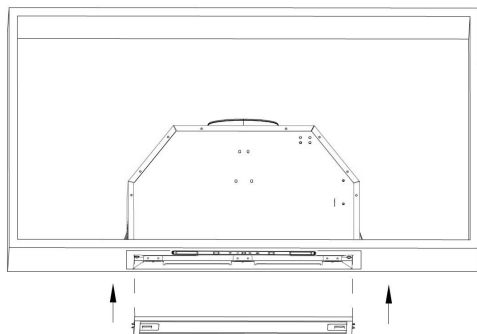

THEA 50

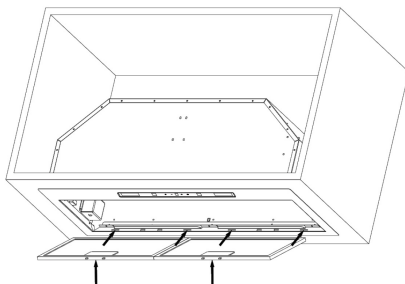

THEA 75

Imaginea 7.

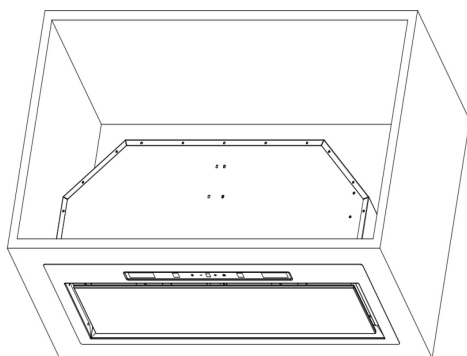

6. Dimensiunea aducției de aer.

THEA - Product Code TH50RCB, TH50RC

THEA 75 - Product Code TH75RCB, TH75RC

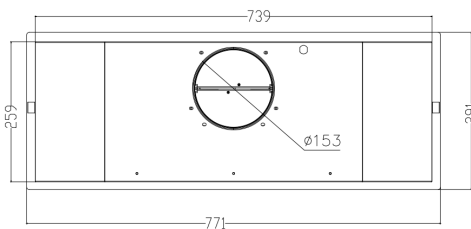
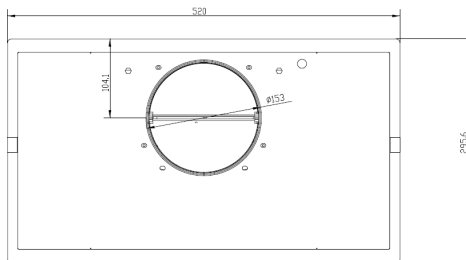

7. Instalarea supapei de închidere (imaginea 8), țevii de aspirație (imaginea 9) și a conexiunii electrice (imaginea 10).

Model No.: THEA - Product Code TH50RCB, TH50RC

Imaginea 8(1)

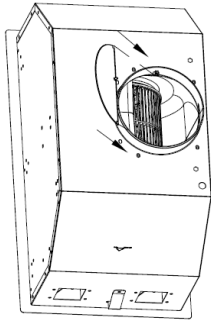

Imaginea 8(2)

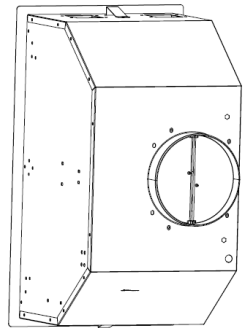

Imaginea 9

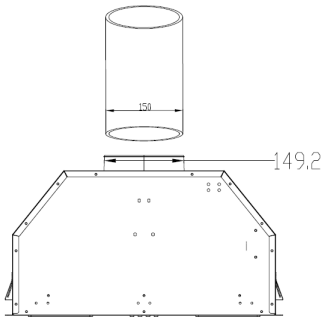

Imaginea 10

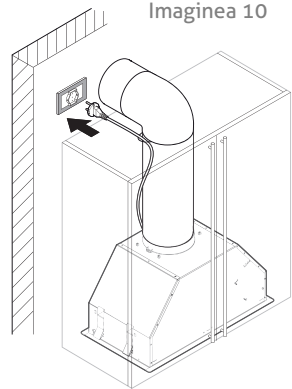

8. Instalarea adaptorului aducției de aer

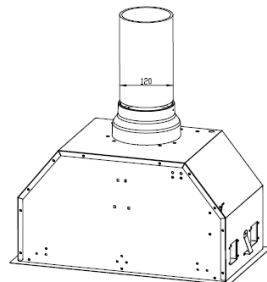
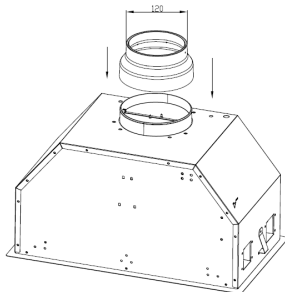

9. Instalarea filtrului de carbon - COD: TCF1 (nu este inclus)

Model No.: THEA - Product Code TH50RCB, TH50RC

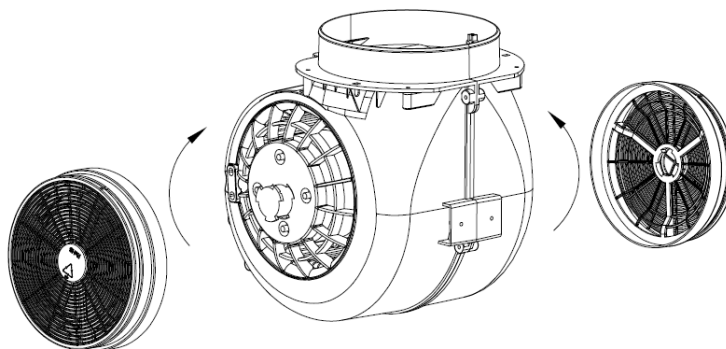

THEA - Cod produs: TH50RCB, TH50RC

Date tehnice

	Valoare	Unit. masura
Capacitatea motorului	800	m ³ /h
Debit maxim de aer al hotei - boost	607	m ³ /h
Debitul de aer al hotei la punctul de lucru - mare	542	m ³ /h
Debitul de aer al hotei la punctul de lucru - scăzut	344	m ³ /h
Putere electrică de intrare	124	W
Puterea nominală a sistemului de iluminat	4	W
Nivel de putere sonoră - boost	67	dB
Nivel de putere sonoră - ridicat	65	dB
Nivel de putere sonoră - scăzut	55	dB
Clasa de eficiență energetică	A+	
Consumul anual de energie	23.4	kWh/a
Diametrul conexiunii - Minim/ Optim	120/ 150	mm

THEA 75 - Cod produs: TH75RCB, TH75RC

Date tehnice

	Valoare	Unit. masura
Capacitatea motorului	800	m ³ /h
Debit maxim de aer al hotei - boost	692	m ³ /h
Debitul de aer al hotei la punctul de lucru - mare	613	m ³ /h
Debitul de aer al hotei la punctul de lucru - scăzut	313	m ³ /h
Putere electrică de intrare	125	W
Puterea nominală a sistemului de iluminat	5	W
Nivel de putere sonoră - boost	66	dB
Nivel de putere sonoră - ridicat	65	dB
Nivel de putere sonoră - scăzut	50	dB
Clasa de eficiență energetică	A++	
Consumul anual de energie	27.2	kWh/a
Diametrul conexiunii - Minim/ Optim	120/150	mm

THEA 50/ 75 - FUNCTII

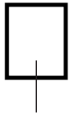

Senzor gesturi



Ecran afisare

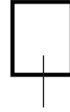

Senzor gesturi



ON/ OFF buton - folosit pentru pornire/oprire unitate



Buton crestere viteza - Pentru setarea Booster apăsați lung această tasta, va reveni la viteză 3 după funcționarea timp de 5 minute în acest mod.



Buton descrestere viteza - pentru a reduce viteza unitatii.



Buton iluminare - pentru a porni sau opri iluminatul unitatii.





Afisaj digital- Afisaj viteza:

"1" pentru viteza redusa, "2" pentru viteza medie, "3" pentru viteza inalta, "B" pentru Booster, "C" pentru functia curatare a aerului.

Functia Quick Timer: Apasati simultan tastele **+** si **-** timp de 1 secunda. Sunt activate: display-ul intermitent si oprirea automata a unitatii dupa 5 minute. Dupa 5 minute motorul se va opri si, daca nu se activeaza o alta functie, un semnal sonor va fi auzit timp de 5 secunde. In timpul functionarii semnalului sonor, acesta poate fi oprit apasarea oricarui buton. Puteți dezactiva functia Quick Timer apăsând din nou simultan tastele **+** si **-**.

Functia curatarea aerului

In modul standby apasati lung  pentru 3 secunde pentru a intra în funcția de curățare a aerului; această funcție permite funcționarea unitatii la viteza redusa timp de 5 minute, dupa care se oprește automat pentru 55 minute. După 55 minute unitatea porneste automat din nou timp de 5 minute și apoi se oprește din nou timp de 55 minute.

"C" este afișat pe ecranul afișajului în timpul funcționării la viteză mică. După ce această funcție este pornită, aceasta poate fi oprită numai apăsând din nou tasta ON timp de 1 secundă, fără a afecta alte operațiuni normale activate (tasta  luminează intermitent la intrarea în funcția de curățare a aerului).

Conectare telecomanda

In modul standby apasati lung butonul  pentru 3 secunde pentru a intra în modul de sincronizare a telecomenzii, lumina indicatoare continuă să clipească.

În modul de sincronizare, apăsați butonul  telecomenzii și se va auzi un semnal sonor, telecomanda s-a conectat cu succes. Dacă nu se efectuează nicio operație sau dacă sincronizarea eșuează după 15 secunde, sistemul revine la starea de standby.



Utilizarea telecomenzii

 **ON/ OFF** buton pornire/ oprire - Utilizat pentru pornirea/oprirea unitatii.

+ **Buton crestere viteza** - Pentru setarea "booster" apăsați lung această tasta ; ventilatorul va reveni la functionarea in treapta a 3-a de viteza după ce a funcționat timp de 5 minute in modul "booster".

- **Buton descrestere viteza** - Pentru a reduce viteza.

 **Buton iluminare** - folosit pentru a porni/ opri iluminatul unitatii.



Control prin gesturi

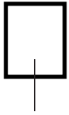

Senzor gesturi



Ecraan afisare



Senzor gesturi

Aceasta functie este disponibila daca unitatea se afla in modul standby.

Sensorii de miscare sunt activati prin trecerea mainii de la stanga la dreapta sau invers prin dreptul panoului de control.

1. Trecerea mainii de la stanga la dreapta determina cresterea treptelor de viteza. Din modul boost, aceeași miscare determina revenirea la viteza minima.

2. Trecerea mainii de la dreapta la stanga, functie disponibila doar cand motorul unitatii este pornit, determina intrarea acesteia in **modul Quick Timer**, dupa care peste 5 minute se va opri. Din modul Quick Timer, aceeași miscare determina oprirea imediata a unitatii.

Treapta de viteza setata ca urmare a controlului prin gesturi, va fi afisata permanent pe display. In modul Quick Timer treapta de viteza va fi afisata intermitent.

CURATAREA SUPRAFETELOR DIN INOX

Pentru a evita deteriorarea suprafeței din oțel inoxidabil a aparatului dumneavoastra

Curățați întotdeauna cu:

Lavete moi, apa distilata sau filtrata, precum si detergenți special realizati pentru oțel inoxidabil.

Nu curățați cu:

Materiale abrazive, pulberi de curățat, înălbitor și alte produse pe bază de clor, detergenți pentru sticlă care conțin amoniac, apa de la robinet mai ales dacă tinde să fie apă dură, detergenți pentru cuptoare.

Deterioarea suprafetelor din inox ca urmare a utilizarii substantelor de curatare necorespunzatoare, nu face obiectul garantiei.

DEPANARE

Defecțiune	Cauză	Soluție
Lumina este aprinsă, însă ventilatorul nu pornește.	Lama ventilatorului este blocată	Lama ventilatorului este blocată. Oprți unitatea și reparați doar cu personal calificat de service.
	Motorul este deteriorat.	
Nu funcționează nici lumina, nici ventilatorul	Bec ars.	Înlocuiți becul cu unul adecvat.
	Pierderi cablu de alimentare.	Alimentați din nou la rețea.
Vibrații serioase ale unității	Lama ventilatorului este deteriorată. Motorul ventilatorului nu este fixat strâns.	Oprți unitatea și reparați doar cu ajutorul personalului calificat de service.
	Unitatea nu este anexată în mod adecvat în suport.	Dați jos unitatea și verificați dacă suportul se află într-o locație adecvată.
Performanța aspirației nesatisfăcătoare	Distanța prea mare între unitate și planul de gătit.	Reglați din nou distanța la 65-75 cm



În conformitate cu reglementarea europeană 2012/19/EU cu privire la deșeurile, acest simbol de pe produs sau de pe ambalajul acestuia indică faptul că produsul nu poate fi tratat drept deșeu casnic. Dimpotrivă, acesta trebuie să fie dus la centru adecvat de colectare în vederea reciclării echipamentului electric și electronic. Asigurându-vă că acest produs este aruncat în mod corect, veți ajuta la prevenirea posibilelor consecințe negative asupra mediului înconjurător și a sănătății umane cauzate de manipularea nepotrivită a acestui produs. Pentru mai multe informații detaliate privind reciclarea acestui produs, contactați consiliul local sau serviciul pentru colectarea deșeurilor casnice.

Producător

Intax Trading SRL
Str. Ion Creanga 14B, 075100, Otopeni, Ilfov, Romania
office@intaxtrading.com
www.intaxtrading.com

SICHERHEITSHINWEISE

- Wir danken Ihnen für den Ankauf dieser Dunstabzugshaube. Lesen Sie aufmerksam die Bedienungsanleitung vor dem Gebrauch der Dunstabzugshaube und bewahren Sie sie sicher!
- Die Montage muss von einem qualifizierten Elektriker oder von einer zuständigen Person durchgeführt werden. Vor der Benutzung der Dunstabzugshaube prüfen Sie über, dass die Spannung (V) und Netzfrequenz (Hz), die auf der Dunstabzugshaube angegeben werden, sind genau dieselben mit der Spannung (V) und Netzfrequenz (Hz) Ihres Haushalts.
- Der Hersteller und der Vertreter haften nicht für die infolge der ungeeigneten Montage und Benutzung der Dunstabzugshaube verursachten Schäden.
- Lassen Sie die Kinder nie, die Dunstabzugshaube handzuhaben.
- Die Dunstabzugshaube ist nur für den Gebrauch in privaten Haushalten gedacht. Ein Grill-, Fastfood-Einsatz und ein gewerblicher Einsatz sind nicht erlaubt!
- Die Dunstabzugshaube und ihre Filter müssen in regelmäßigen Abständen gründlich gereinigt werden, um betriebsbereit zu bleiben.
- Vor der Reinigung muss die Haube vom Stromnetz getrennt werden.
- Reinigen Sie die Haube gemäß der Bedienungsanleitung und schützen Sie sie vor Brandgefahr.
- Die Lagerung der Haube neben einer Wärmequelle ist verboten.
- Gibt es einen Mangel des Gerätes, dann rufen Sie Service-Abteilung und bitten Sie um einen Serviceingenieur.
- Dieses Gerät kann von Kindern ab 8 Jahren und Personen mit reduzierten physischen, sensorischen oder mentalen Fähigkeiten oder Mangel an Erfahrung oder Wissen benutzt werden, wenn sie von einer Person, die für ihre Sicherheit verantwortlich ist, beaufsichtigt oder von ihr bezüglich des sicheren Gebrauchs des Gerätes unterwiesen wurden und sie die daraus resultierenden Gefahren verstanden haben. Kinder dürfen nicht mit dem Gerät spielen. Reinigung und Wartung dürfen nicht durch Kinder ohne Beaufsichtigung durchgeführt werden.
- Ist das Stromkabel beschädigt, muss es durch Hersteller, Service-Agenten oder andere ähnliche qualifizierte Personen ersetzt werden, um eine Gefahr zu vermeiden.
- Die Hinweise werden folgendes angeben: immer für ausreichende Zuluft sorgen, wenn das Gerät gleichzeitig mit gas- oder brennstoffbetriebenen Geräten verwendet wird (nicht anwendbar für die Geräte, die nur die Luft zurück in den Raum führen)
- Flambieren Sie nie unter der Haube. Die zugänglichen Teile können heiß werden, wenn sie gleichzeitig mit Kochgeräten gebraucht werden.

Wichtige Hinweise für Montage

- Die Luftzuführung muss nicht durch einen Schonstein für gas- oder brennstoffbetriebene Geräten (nicht anwendbar für die Geräte, die nur die Luft zurück in den Raum führen) erfolgen.
- Die Regelungen für den Entzug der Luft müssen beachtet werden.

Wichtige Hinweise über Abluftbetrieb



WARNUNG

Zurückgesaugte Verbrennungsgase können zu Vergiftungen führen. Immer für ausreichend Zuluft sorgen, wenn das Gerät im Abluftbetrieb gleichzeitig mit einer raumluftabhängigen Feuerstätte verwendet wird.

Raumluftabhängige Feuerstätten (z. B. gas-, öl-, holz- oder kohlebetriebene Heizgeräte, Durchlauferhitzer, Warmwasserbereiter) beziehen Verbrennungsluft aus dem Aufstellraum und führen die Abgase durch eine Abgasanlage oder ein Kamin ins Freie. In Verbindung mit einer eingeschalteten Dunstabzugshaube wird der Küche und den benachbarten Räumen Raumluft entzogen - ohne ausreichende Zuluft entsteht ein Unterdruck. Giftige Gase aus dem Kamin oder Abzugsschacht werden in die Wohnräume zurückgesaugt.

- Es muss daher immer für ausreichende Zuluft gesorgt werden
- Ein Zuluft-/Abluftmauerkasten allein stellt die Einhaltung des Grenzwertes nicht sicher.

Ein gefahrloser Betrieb ist nur dann möglich, wenn der Unterdruck im Aufstellraum der Feuerstätte 4 Pa (0,04 mbar) nicht überschreitet. Dies kann erreicht werden, wenn durch nicht verschließbare Öffnungen, z. B. in Türen, Fenstern, in Verbindung mit einem Zuluft- / Abluftmauerkasten oder durch andere technische Maßnahmen, die zur Verbrennung benötigte Luft nachströmen kann. Ziehen Sie in jedem Fall den Rat des zuständigen Schornsteinfegermeisters hinzu, der den gesamten Lüftungsverbund des Hauses beurteilen kann und Ihnen die passende Maßnahme zur Belüftung vorschlägt.

Wird die Dunstabzugshaube ausschließlich im Umluftbetrieb eingesetzt, ist der Betrieb ohne Einschränkung möglich.



WARNUNG

Brandgefahr wegen der Funken. Gerät nur dann in der Nähe einer Feuerstätte für feste Brennstoffe (z.B. Holz oder Kohle) installieren, wenn eine geschlossene, nicht abnehmbare Abdeckung vorhanden ist.

ABMESSUNGEN

Model No.: THEA - Product Code TH50RCB, TH50RC

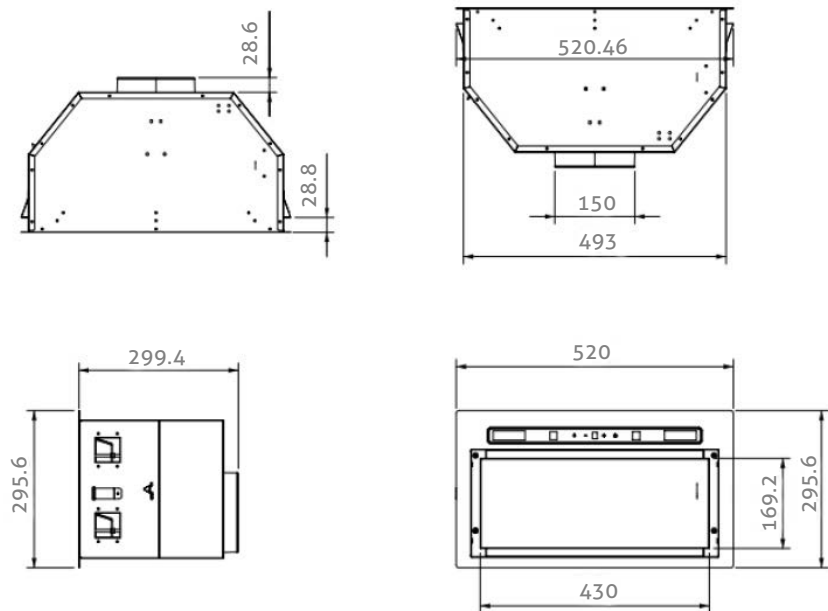

ABMESSUNGEN

Model No.: THEA - Product Code TH75RCB, TH75RC

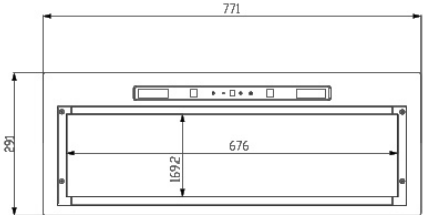
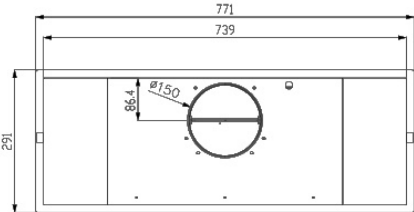
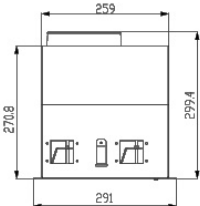
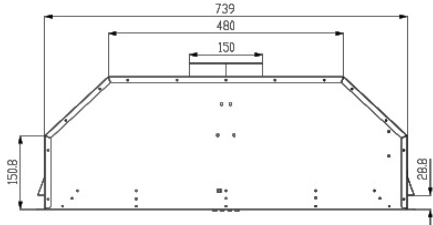

MONTAGE

Anmerkung: Funktionieren die Haube und eine mit einer nichtelektrischen Energiequelle betriebene Maschine gleichzeitig, dann muss der Unterdruck im Raum 4 Pa (4×10^{-5} Bar) nicht überschreiten.

Erforderlicher Mindestabstand zu

Glaskeramikkochfeldern/Herdplatten	65 cm
Gasherd	75 cm
Feuer Kochplatte mit Holz/Kohle/Öl	85 cm

MONTAGESCHRITTE

Anmerkung: Schließen Sie das Stromkabel nicht an, bevor Sie die Montage beenden!
Bitte Sie eine andere Person darum, dass sie Ihnen bei der Montage hilft.

1. Machen Sie eine Öffnung an der Wand des Schrankes, worunter die Haube montiert wird. Beachten sie die folgenden Abmessungen:

MESSUNGEN DER ÖFFNUNGEN FÜR MONTAGE (mm)

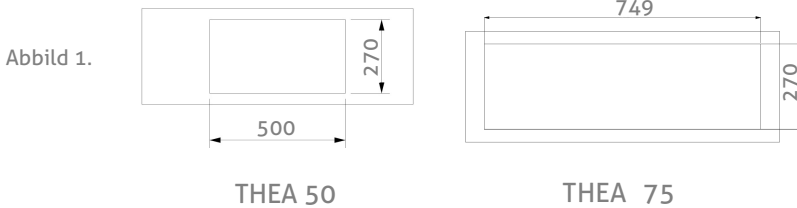

2. Bauen Sie die Haube in den Schrank ein. Es ist sicherzustellen, dass die Federklammern von den beiden Seiten am Schrank befestigt werden.

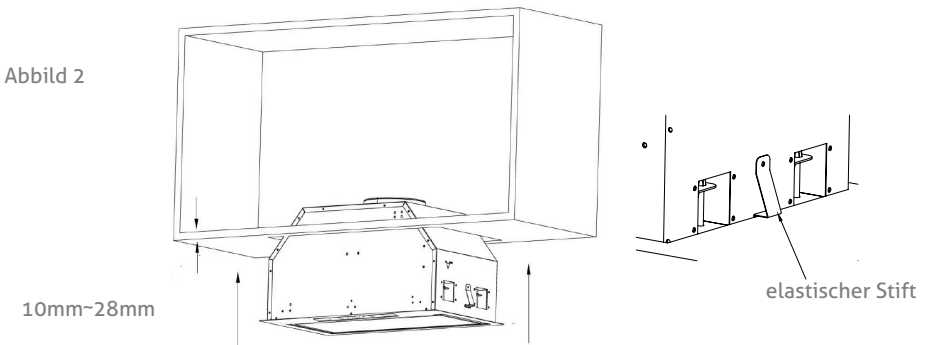

3. Entfernen Sie die Metallfettfilter.

Abbild 3.

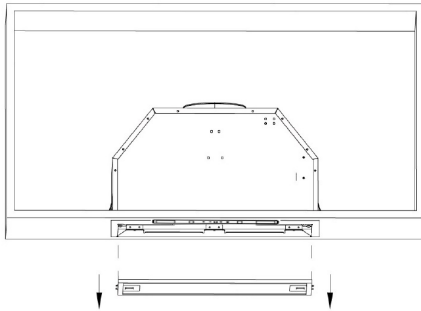

THEA 50

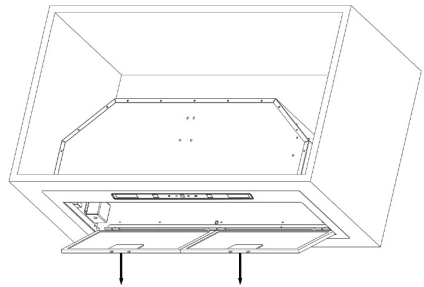

THEA 75

4. Ziehen Sie die Schrauben 1. 2. 3. 4. an, bis die Flansche auf den beiden Seiten am Schrank wie im Abbild 5 befestigt werden.

Abbild 4.

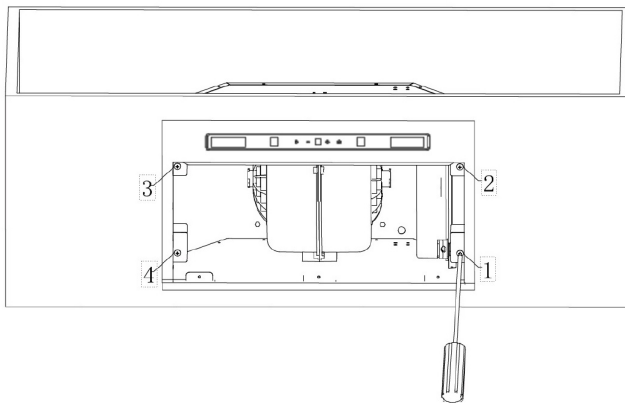

Abbild 5.

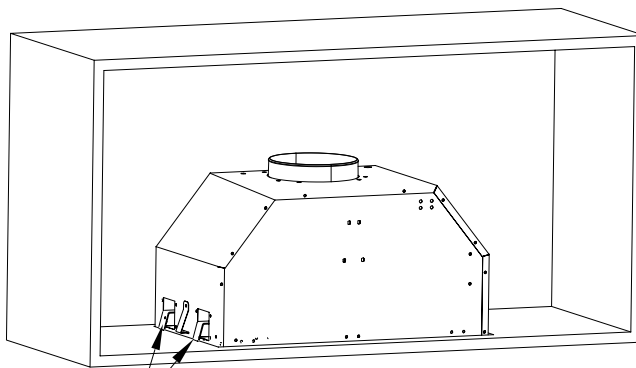

Flansche

5. Bauen Sie die Metallfettfilter (Abbild 6) wieder ein und beenden Sie die Montage (Abbild 7).

Abbild 6.

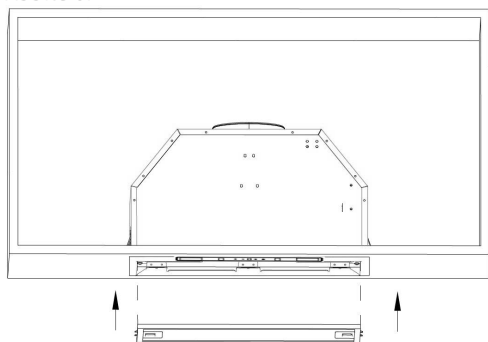

THEA 50

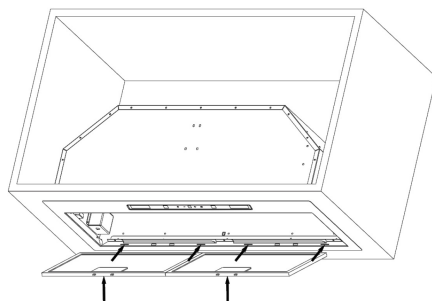

THEA 75

Abbild 7.

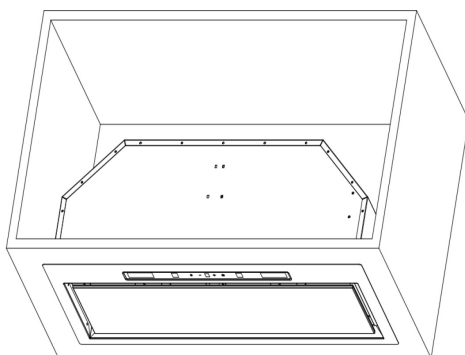

6. Abmessung des Luftstroms.

THEA - Product Code TH50RCB, TH50RC

THEA 75 - Product Code TH75RCB, TH75RC

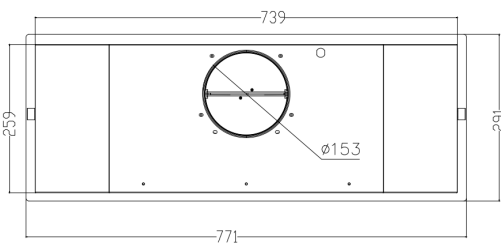
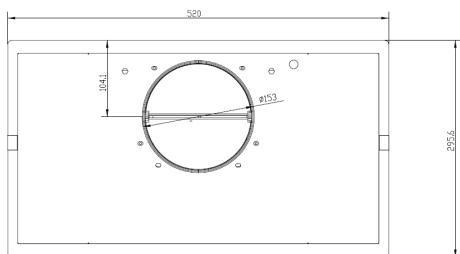

7. Montage des Absperrventils (Abbild 8), der Saugleitung (Abbild 9) und des elektrischen Anschlusses (Abbild 10).

THEA - Product Code TH50RCB, TH50RC

Abbild 8(1)

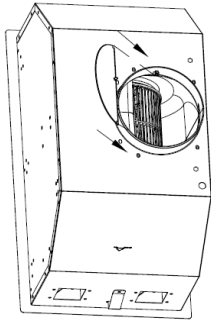

Abbild 8(2)

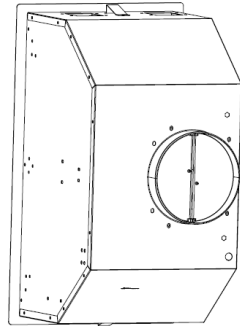

Abbild 9

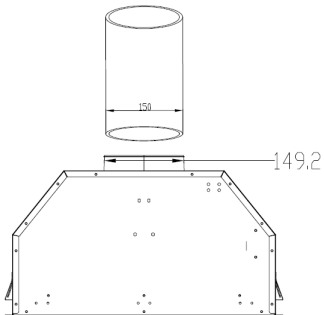

Abbild 10

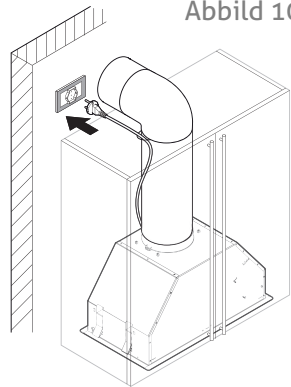

8. Montage des Adapters des Luftstroms

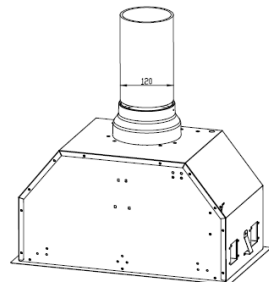
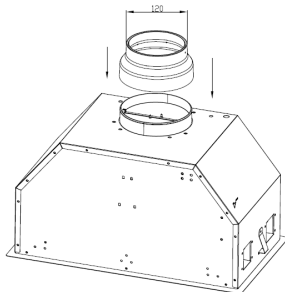

9.Montage des Karbonfilters - CODE: TCF1 (nicht eingeschlossen)

THEA - Product Code TH50RCB, TH50RC

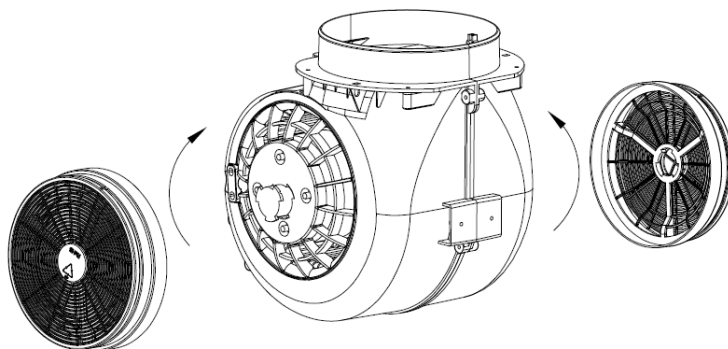

THEA - Product Code TH50RCB, TH50RC

Technische Daten

	Value	Einheit
Motorleistung	800	m ³ /h
Maximaler Luftstrom der Dunstabzugshaube - boost	607	m ³ /h
Luftstrom der Dunstabzugshaube am Arbeitspunkt - hoch	542	m ³ /h
Luftstrom der Dunstabzugshaube am Arbeitspunkt - niedrig	344	m ³ /h
Stromaufnahme	124	W
Nennleistung des Beleuchtungssystems	4	W
Schalleistungspegel - Boost	67	dB
Schalleistungspegel - hoch	65	dB
Schalleistungspegel - niedrig	55	dB
Energieeffizienzklasse	A+	
Jährlicher Energieverbrauch	23.4	kWh/a
Anschlussdurchmesser - Minimum/ Optimum	120/ 150	mm

THEA 75 - Product Code TH75RCB, TH75RC

Technische Daten

	Value	Einheit
Motorleistung	800	m ³ /h
Maximaler Luftstrom der Dunstabzugshaube - boost	632	m ³ /h
Luftstrom der Dunstabzugshaube am Arbeitsplatz - hoch	613	m ³ /h
Luftstrom der Dunstabzugshaube am Arbeitsplatz - niedrig	313	m ³ /h
Stromaufnahme	125	W
Nennleistung des Beleuchtungssystems	5	W
Schalleistungspegel - Boost	66	dB
Schalleistungspegel - hoch	65	dB
Schalleistungspegel - niedrig	50	dB
Energieeffizienzklasse	A++	
Jährlicher Energieverbrauch	27.2	kWh/a
Anschlussdurchmesser - Minimum/ Optimum	120/150	mm

THEA 50/ 75 - Funktionen

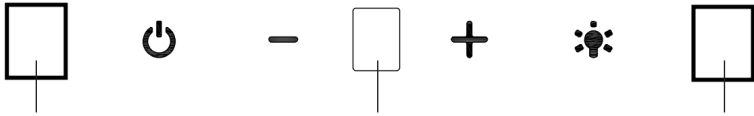

Gestensensor

Bildschirm

Gestensensor



Ein-/Ausschalten-Taste Benutzt zum Ein- oder Ausschalten der Einheit.



Geschwindigkeitserhöhung-Taste - Für die Booster-Einstellung diesen Knopf lange drücken. Nach 5 Minuten im Booster-Modus schaltet die Einheit auf Geschwindigkeitsstufe 3.



Geschwindigkeitsverringerung-Taste - Benutzt für das Reduzieren der Geschwindigkeit.





Beleuchtung-Taste



Digitales Display - "1": geringe Geschwindigkeit, "2": mittlere Geschwindigkeit, "3": hohe Geschwindigkeit. "B": Booster, "C" Luftreinigungsfunktion.

Quick-Timer-Funktion - Beim gleichzeitigen Drücken der Tasten Plus und Minus **+** **-** für eine Sekunde werden das Display und die automatische Ausschaltung nach 5 Minuten aktiviert. Nach 5 Minuten schaltet sich der Motor ab, wenn keine andere Funktion abgerufen wird; ein Tonsignal ist für 5 Sekunden zu hören. Während des Tonsignals kann dieser durch Drücken jeder Taste stummgeschaltet werden. Die Quick-Timer-Funktion kann durch gleichzeitiges Drücken der Tasten **+** **-** wieder deaktiviert werden.

Luftreinigungsfunktion

Im Standby-Modus halten Sie die Taste  für 3 Sekunden gedrückt, um die Luftreinigungsfunktion zu aktivieren; durch das Aktivieren dieser Funktion schaltet sich die Einheit ein und läuft bei geringer Geschwindigkeit 5 Minuten lang. Danach schaltet sie sich automatisch für 55 Minuten aus. Nach diesen 55 Minuten schaltet sie sich automatisch wieder ein und läuft wieder 5 Minuten lang. Dann schaltet sie sich für 55 Minuten wieder aus. Auf dem Display wird stetig "C" gezeigt, während des Laufs bei geringer Geschwindigkeit. Nachdem diese Funktion aktiviert wurde, kann sie durch Drücken der Taste ON 1 Sekunde lang wieder deaktiviert. Dies beeinträchtigt nicht den Ausführung anderer aktivierten normalen Funktionen (die Taste  blinkt beim Einschalten der Luftreinigungsfunktion).





EINSCHLIEßEN DER FERNBEDIENUNG

Im Standby-Modus halten Sie die Taste  3 Sekunden lang gedrückt, um in den Synchronisierungs-Modus der Fernbedienung zu gelangen. Die Leuchte wird weiter blinken.

Im Synchronisierungs-Modus drücken Sie die Taste  der Fernbedienung; ein Tonsignal ist zu hören, die Fernbedienung ist erfolgreich angeschlossen. Wenn es keine weitere Eingabe erfolgt oder wenn die Synchronisierung nach 15 Sekunden scheitert, wird das System in den Standby-Modus heruntergefahren.



Benutzen der Fernbedienung

-  **On/Off Taste zum Ein-/Ausschalten** - Wird zum Ein- oder Ausschalten der Einheit benutzt.
-  **Geschwindigkeitserhöhung-Taste** - Der Booster-Modus wird durch langes Drücken dieser Taste eingeschaltet; nach 5- minütigem Lauf im Booster-Modus schaltet der Ventilator automatisch auf Geschwindigkeitsstufe 3 um.
-  **Geschwindigkeitsverringern-Taste**
Wird zum Verringern der Geschwindigkeit benutzt.
-  **Beleuchtung-Taste**



Steuerung durch Gesten

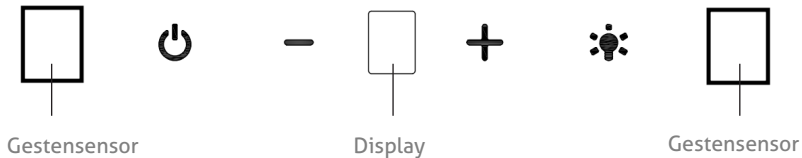

Diese Funktion ist verfügbar, wenn sich das Gerät im Standby-Modus befindet. Bewegungssensoren werden aktiviert, indem die Hand von links nach rechts oder umgekehrt durch das Bedienfeld geführt wird.

1. Bewegen der Hand von links nach rechts erhöht die Geschwindigkeitsstufe. Aus dem Boost-Modus bewirkt die gleiche Bewegung die Rückkehr zur minimalen Geschwindigkeit.
2. Wenn Sie die Hand von rechts nach links führen, eine Funktion, die nur verfügbar ist, wenn der Motor des Geräts eingeschaltet ist, wechselt es in den **Quick-Timer-Modus**, wonach es nach 5 Minuten stoppt. Im Quick-Timer-Modus bewirkt dieselbe Bewegung, dass das Gerät sofort stoppt.

Die per Gestensteuerung eingestellte Geschwindigkeitsstufe wird dauerhaft im Display angezeigt. Im Quick-Timer-Modus wird die Geschwindigkeitsstufe intermittierend angezeigt.

Edelstahloberflächen reinigen

Um Schäden an der Edelstahloberfläche Ihres Geräts zu vermeiden

Immer sauber mit:

Weiche Tücher, destilliertes oder gefiltertes Wasser sowie speziell für Edelstahl hergestellte Reinigungsmittel.

Nicht reinigen mit:

Scheuermittel, Reinigungspulver, Bleich- und andere Produkte auf Chlorbasis, ammoniakhaltige Glasreiniger, Leitungswasser, insbesondere wenn es zu hartem Wasser neigt, Ofenreiniger.

Schäden an Edelstahloberflächen durch die Verwendung unsachgemäßer Reinigungsmittel fallen nicht unter die Gewährleistung.

STÖRUNGSBESEITIGUNG

Störung	Ursache	Lösung
Es gibt Beleuchtung, aber der Lüfter kann nicht eingeschaltet werden.	Die Klinge des Lüfters ist gesperrt.	Schalten Sie das Gerät aus und führen Sie die Reparatur nur durch einen geschulten Kundendienst-Techniker durch.
	Motor ist beschädigt.	
Weder Beleuchtung, noch Lüfter funktioniert nicht	Gebrannte Glühlampe.	Austausch der Glühlampe.
	Verluste des Stromkabels.	Gerät am Stromnetz neu anschließen.
Ernste Vibrationen des Gerätesvibra	Die Klinge des Lüfters ist beschädigt. Der Motor des Lüfters wird nicht gut befestigt.	Schalten Sie das Gerät aus und führen Sie die Reparatur nur durch einen geschulten Kundendienst-Techniker durch.
	Das Gerät nicht gut auf Trägern befestigt.	Nehmen Sie das Gerät heraus und prüfen Sie, ob es auf Trägern gut befestigt wird.
Ungenügende Absaugleistung	Zu großer Abstand zwischen Gerät und Kochfeld.	Stellen Sie den Abstand neu 65-75 cm ein



Gemäß der europäischen Richtlinie 2012/19/EU über Abfälle gibt diese Kennzeichnung auf dem Produkt oder dessen Verpackung an, dass das Produkt nicht als Haushaltsabfall behandelt werden kann. Es muss zu einem Zentrum für Sammlung der Elektrik- und Elektronikaltgeräte entsorgt werden. Durch eine richtige Entsorgung vermeiden Sie die möglichen schädlichen Auswirkungen auf Umwelt und menschliche Gesundheit infolge des ungeeigneten Umgangs mit diesem Produkt. Für mehrere detaillierte Infos über die Entsorgung dieses Produkts kontaktieren Sie den Stadtrat oder Dienst für Sammlung der Haushaltsabfälle.

Manufacturer

Intax Trading SRL
 Ion Creanga 14B Str., 075100, Otopeni, Ilfov, Romania
 office@intaxtrading.com
 www.intaxtrading.com

INSTRUCCIONES DE SEGURIDAD

- Gracias por comprar esta campana extractora de cocina. Lea atentamente el manual de instrucciones antes de utilizar la campana y guárdelo en un lugar seguro.
- La instalación deber ser realizada por un electricista calificado o por una persona competente. Antes de utilizar la campana, asegúrese de que la tensión eléctrica (V) y la frecuencia (Hz) indicadas en la campana son idénticas con la tensión eléctrica (V) y la frecuencia (Hz) de su casa.
- El fabricante y el agente no son responsables por los daños causados por la instalación y uso inadecuados de la campana.
- Nunca permita que los niños manipulen la campana.
- La campana es estrictamente para uso doméstico. No es apta para parillas, tiendas de comida rápida y para fines comerciales.
- La campana y su filtro se deben limpiar regularmente para mantenerla en buen estado de funcionamiento.
- Antes de limpiarla, apague la alimentación de la fuente principal.
- Limpie la campana de acuerdo con el manual de instrucciones y manténgala fuera del peligro de quemaduras.
- Está prohibido almacenar la campana cerca de una fuente de fuego.
- Si hay cualquier defecto del equipo, llame al departamento de servicio para solicitar un ingeniero de servicio.
- Este equipo puede ser utilizado por niños de 8 años o más y por personas con capacidades físicas, sensoriales y mentales reducidas o sin experiencia o conocimiento, si han sido supervisados o instruidos en relación con el uso seguro del equipo y si entienden los peligros involucrados. A los niños le está prohibido jugar con el equipo. La limpieza y mantenimiento no deben ser realizados por niños sin supervisión.
- Si el cable de alimentación está dañado, se debe reemplazar por el fabricante, su agente de servicio o por otras tales personas calificadas para evitar una situación peligrosa.
- Las instrucciones indicarán lo siguiente: habrá una ventilación adecuada de la habitación cuando la campana se use en paralelo con equipos de gas u otros combustibles (no se aplica a los equipos que sólo devuelven el aire en la habitación)
- No flamee debajo de la campana. Las partes accesibles se pueden calentar cuando se utilizan junto con electrodomésticos de cocina.

Indicaciones importantes para la instalación

- El aire no se debe evacuar por una chimenea utilizada para eliminar el gas que procede de los equipos de gas u otros combustibles (no se aplica a los equipos que sólo devuelven el aire en la habitación).
- Se debe cumplir con las normas de eliminación de aire.

Notas importantes sobre el modo de extracción



AVISO

Riesgo de intoxicación con los gases evacuados succionados. Nunca use el dispositivo en el modo de extracción al mismo tiempo que un equipo con chimenea de tiro abierta a menos que se garantice un flujo de aire adecuado.

El equipo abierto de combustión de gases (por ejemplo gas, petróleo, leña o calentadores de carbón, calentadores instantáneos de agua, calderas) extrae el aire de combustión de la habitación y lo transporta afuera a través de un tubo de evacuación o una chimenea. En el modo de extracción, el aire interior se elimina de la cocina y las habitaciones adyacentes – sin aire suficiente, esto crea un vacío. Por lo tanto, los gases tóxicos de la chimenea o de la chimenea de tira pueden devolver a los espacios de la vivienda.

- Asegúrese siempre de que se suministre suficiente aire fresco y de que el mismo pueda circular.
- Sólo una alimentación con aire/caja extractora no puede garantizar el cumplimiento de valor límite.

La operación segura es posible sólo cuando la presión negativa en la habitación donde está ubicado el equipo no excede 4 Pa (0.04 mbar). Esto se puede lograr cuando el aire necesario para la combustión puede pasar por orificios que no se pueden cerrar, por ejemplo puertas, ventanas, junto con una alimentación con aire/caja extractora o por otros medios técnicos. En cualquier caso, consulte con un deshollinador calificado que puede evaluar la ventilación de su casa y que le puede proponer medidas apropiadas para una ventilación adecuada. Si la campana se utiliza exclusivamente en el modo de recirculación, la operación sin restricciones es posible.



AVISO

Peligro de incendio por chispas. Instale el equipo en una chimenea para combustibles sólidos (por ejemplo leña o carbón) sólo si hay una tapa cerrada, no extraíble.

TAMAÑOS

Model No.: THEA - Product Code TH50RCB, TH50RC

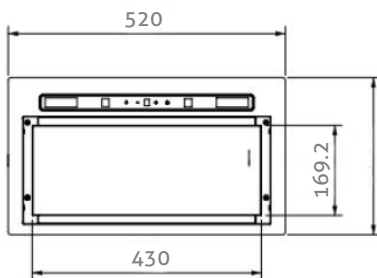
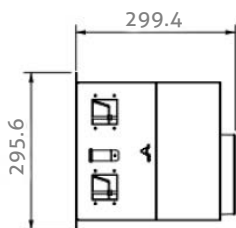
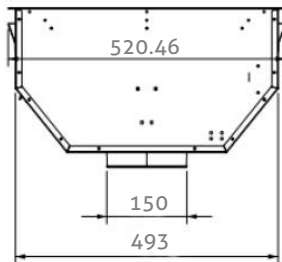
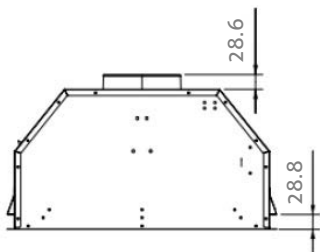

TAMAÑOS

Model No.: THEA 75 - Product Code TH575CB, TH75RC

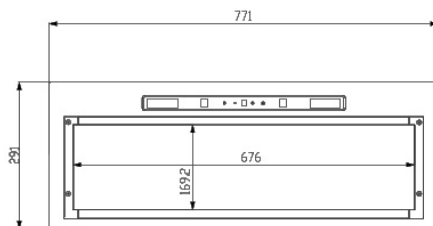
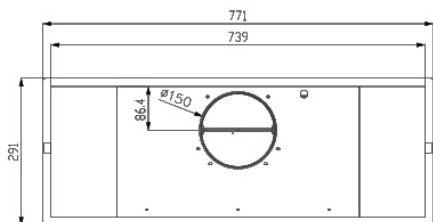
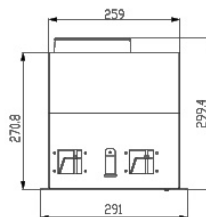
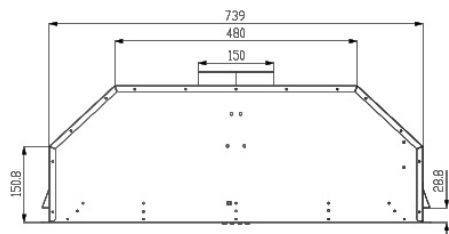

INSTALACIÓN

Nota: Cuando la campana y el equipo alimentado con una energía distinta de la eléctrica funcionan al mismo tiempo, la presión negativa de la habitación no debe exceder 4 Pa (4×10^{-5} Bar).

Distancia mínima requerida entre la campana y

Anillos de vidrio cerámico/placas	65 cm
Cocina de gas	75 cm
Fuego de a placa de leña/carbón/aceite	85 cm

PASOS DE INSTALACIÓN

Nota: ¡No conecte el cable de alimentación hasta que se finalice la instalación! Llame a una segunda persona para ayudarle con la instalación.

1. Corte un agujero en la pared del gabinete debajo del cual se montará la campana. Use las siguientes dimensiones como guía:

MEDICIONES DE LOS ORIFICIOS PARA LA INSTALACIÓN (mm)

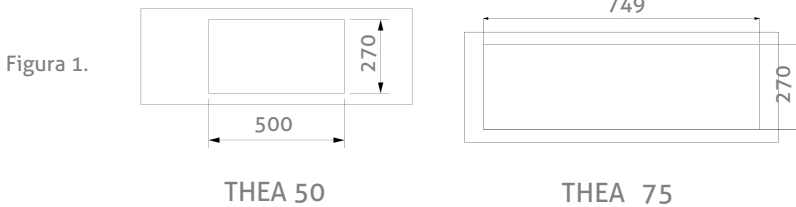

2. Inserte la campana en el gabinete. Asegúrese de que las abrazaderas elásticas estén fijadas al gabinete en ambos lados.

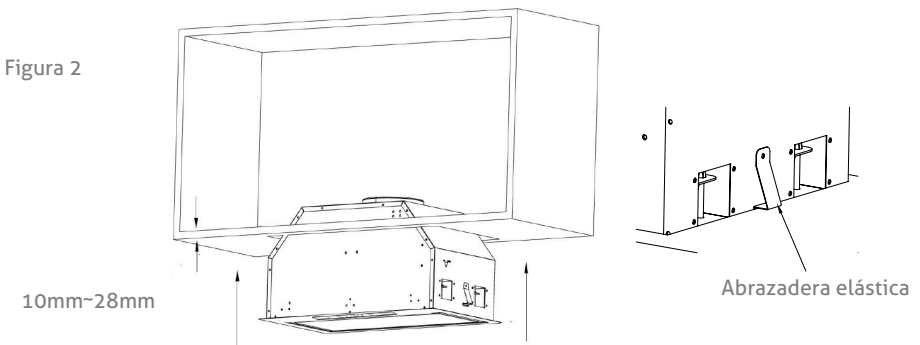

3. Retire el filtro metálico de grasa.

Figura 3.

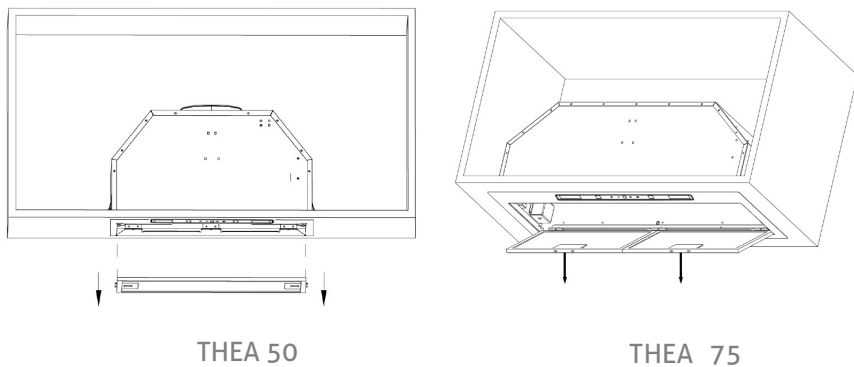

4. Ajuste los tornillos 1. 2. 3. 4. Hasta que las bridas de ambos lados estén fijadas al gabinete como en la figura 5.

Figura 4.



Figura 5.



5.Reinstale el filtro metálico de grasa (figura 6) y finalice a instalación (figura 7).

Figura 6.

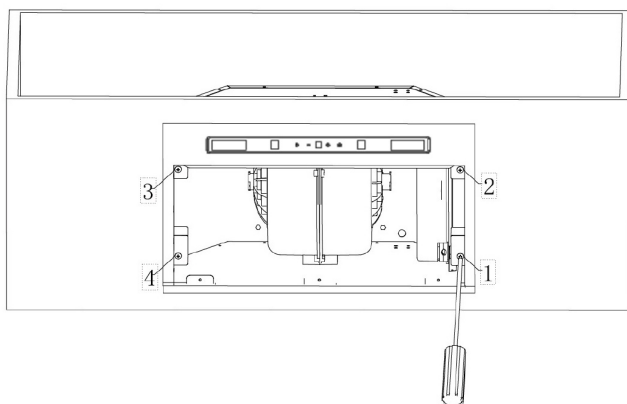
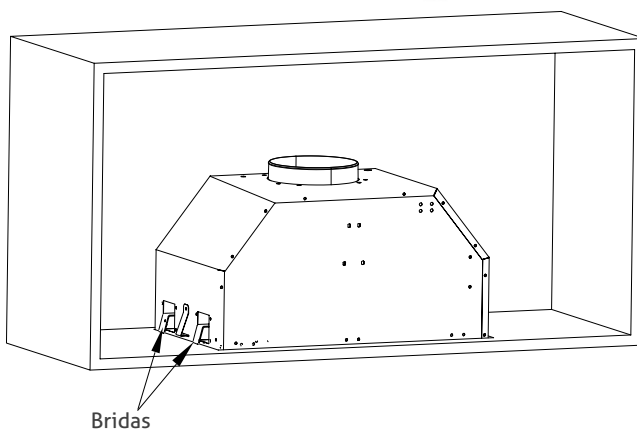

Figura 7.



6.Tamaño del suministro de aire.

THEA - Product Code TH50RCB, TH50RC

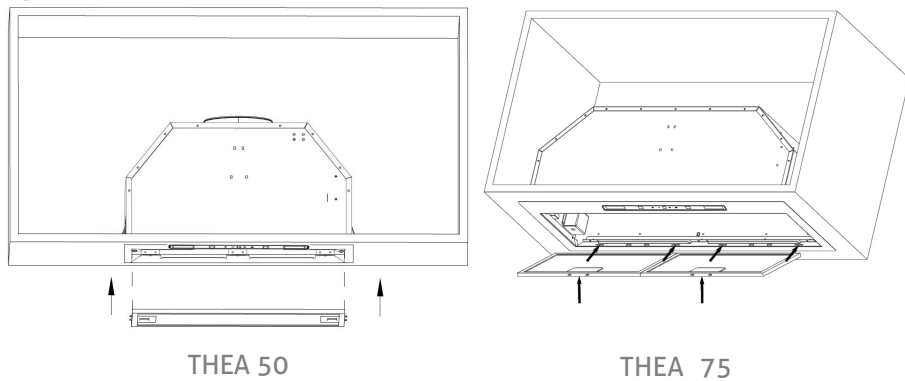
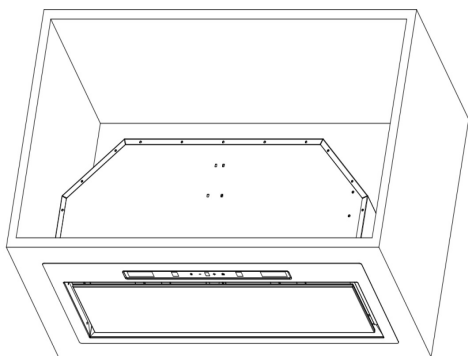
THEA 75 - Product Code TH75RCB, TH75RC

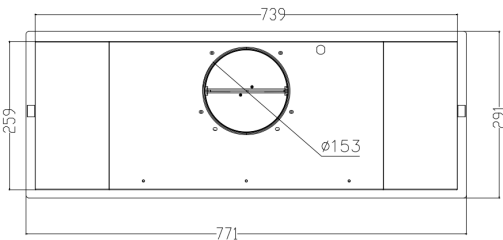
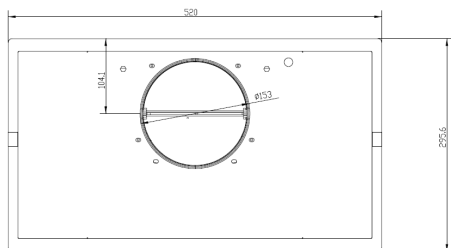

7.Instalación de la válvula de cierre (figura 8), del tubo de succión (figura 9) y de la conexión eléctrica (figura 10).

Model No.: THEA - Product Code TH50RCB, TH50RC

Figura 8(1)



Figura 8(2)



Figura 9

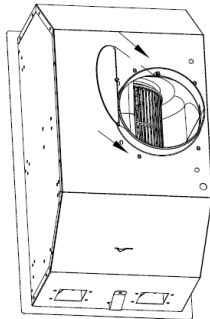

Figura 10

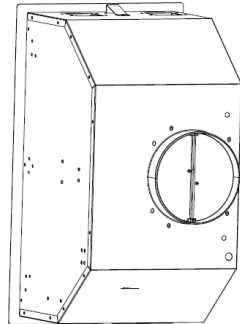

8.Instalación del adaptador de entrada de aire

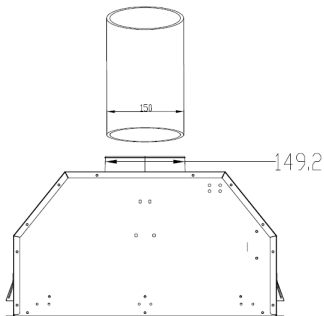
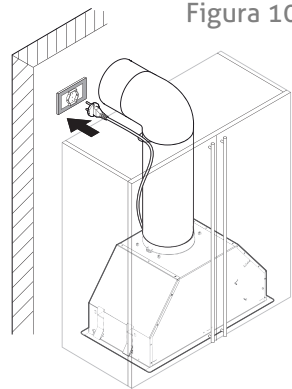
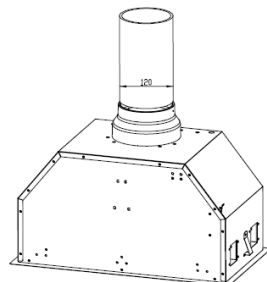
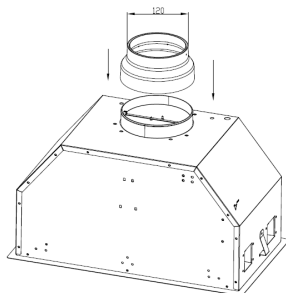

9. Instalación del filtro de carbón - **Código: TCF1** (no está incluida)

Model No.: THEA - Product Code TH50RCB, TH50RC

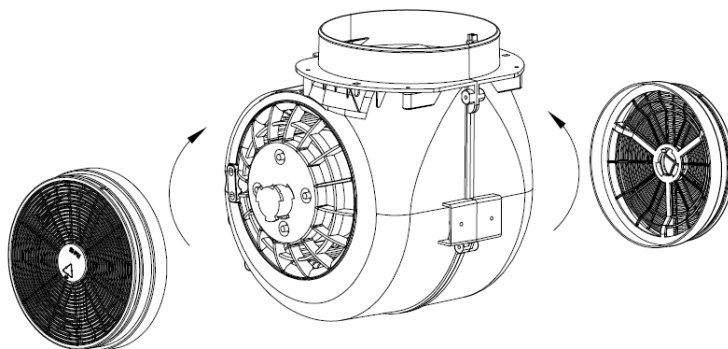

THEA - Product Code TH50RCB, TH50RC

Datos técnicos

	Valor	Unidad
Capacidad del motor	800	m ³ /h
Caudal máximo de aire de la campana extractora - Boost	607	m ³ /h
Flujo de aire de la campana extractora en el punto de trabajo-alto	542	m ³ /h
Flujo de aire de la campana extractora en el punto de trabajo-bajo	344	m ³ /h
Entrada de energía eléctrica	124	W
Potencia nominal del sistema de iluminación	4	W
Nivel de potencia acústica: impulso	67	dB
Nivel de potencia acústica: alto	65	dB
Nivel de potencia acústica: bajo	55	dB
Clase de eficiencia energética	A+	
Consumo de energía anual	23.4	kWh/a
Diámetro de conexión - Mínimo/ Optimo	120/ 150	mm

THEA 75 - Product Code TH75RCB, TH75RC

Datos técnicos

	Valor	Unidad
Capacidad del motor	800	m ³ /h
Caudal máximo de aire de la campana extractora - Boost	692	m ³ /h
Flujo de aire de la campana extractora en el punto de trabajo - alto	613	m ³ /h
Flujo de aire de la campana extractora en el punto de trabajo - bajo	313	m ³ /h
Entrada de energía eléctrica	125	W
Potencia nominal del sistema de iluminación	5	W
Nivel de potencia acústica: impulso	66	dB
Nivel de potencia acústica: alto	65	dB
Nivel de potencia acústica: bajo	50	dB
Clase de eficiencia energética	A++	
Consumo de energía anual	27.2	kWh/a
Diámetro de conexión - Mínimo/ Optimo	120/150	mm

THEA 50/ 75 - FUNCIONES

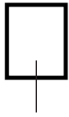

Sensor de gestos



Pantalla de visualización

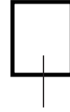

Sensor de gestos



Botón de encendido/apagado - utilizado para encender/apagar el equipo



Botón para incrementar la velocidad - Para configurar el booster, mantenga presionada esta tecla, volverá a la 3a velocidad después de funcionar durante 5 minutos en este modo.



Botón para disminuir la velocidad - Para disminuir la velocidad



Botón Iluminación



Visualización digital - Visualización de la velocidad: "1" para baja velocidad, "2" para velocidad media, "3" para alta velocidad, "B" para booster, "C" para la función de limpieza de aire.

Función Quick Timer: Presionar simultáneamente las teclas **+** y **-** durante un segundo. Se activa la visualización intermitente y el apagado automático del equipo después de 5 minutos. Después de 5 minutos, el motor se detendrá y, si no se activa ninguna otra función, se escuchará una señal acústica durante 5 segundos. Durante la señal acústica, se puede detener presionando cualquier botón. Puede desactivar la función Quick Timer presionando de nuevo las teclas **+** **-** simultáneamente.



Función de limpieza de aire

En el modo de espera, mantenga presionado  durante 3 segundos para ingresar a la función de limpieza de aire; esta función permite que el equipo funcione a baja velocidad durante 5 minutos, después de lo cual se apaga automáticamente durante 55 minutos.

Después de 55 minutos, el equipo se vuelve a encender automáticamente durante 5 minutos y luego se apaga nuevamente durante 55 minutos.





"C" se muestra en la pantalla de visualización durante el funcionamiento a baja velocidad. Una vez activada esta función, sólo se puede desactivar pulsando de nuevo la tecla ON durante un segundo, sin que ello afecte al resto de operaciones normales activadas (la tecla  parpadea al entrar en la función de limpieza de aire).

CONEXIÓN DE CONTROL REMOTO

En el modo de espera, mantenga presionado el botón  durante 3 segundos para ingresar al modo de sincronización del control remoto, la luz indicadora continúa parpadeando. En el modo de sincronización, presione el botón  del control remoto y se escuchará una señal acústica, el control remoto se ha conectado correctamente. Si no se realiza ninguna operación o la sincronización falla, después de 15 segundos, el sistema vuelve al modo de espera.



Uso del control remoto

-  **Botón de encendido/apagado** - Utilizado para encender/apagar el equipo.
-  **Botón para incrementar la velocidad** - Para configurar el "booster", mantenga presionada esta tecla; el ventilador volverá a funcionar en 3a velocidad después de operar durante 5 minutos en modo de "booster".
-  **Botón para disminuir la velocidad**
-  **Botón Iluminación**



Control por gesto

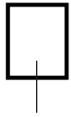

Sensor de gestos



Pantalla de visualización

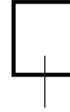

Sensor de gestos

Esta función está disponible si la unidad está en modo de espera.

Los sensores de movimiento se activan pasando la mano de izquierda a derecha o viceversa por el panel de control.

1. Mover la mano de izquierda a derecha aumenta el nivel de velocidad. Desde el modo boost, el mismo movimiento provoca el retorno a la velocidad mínima.
2. Al pasar la mano de derecha a izquierda, función disponible solo cuando el motor de la unidad está encendido, hace que entre en el modo **Quick Timer**, luego de lo cual se detendrá después de 5 minutos. Desde el modo Quick Timer, el mismo movimiento hace que la unidad se detenga inmediatamente.

El nivel de velocidad establecido como resultado del control por gestos se mostrará permanentemente en la pantalla. En el modo de temporizador rápido, el nivel de velocidad se mostrará de forma intermitente.

LIMPIEZA DE SUPERFICIES DE ACERO INOXIDABLE

Para evitar dañar la superficie de acero inoxidable de su electrodoméstico

Limpiar siempre con:

Paños suaves, agua destilada o filtrada, así como detergentes especiales para acero inoxidable.

No limpiar con:

Materiales abrasivos, polvos de limpieza, lejía y otros productos a base de cloro, limpiacristales que contengan amoníaco, agua del grifo, especialmente si tiende a ser agua dura, limpiadores de hornos.

La garantía no cubre los daños a las superficies de acero inoxidable debido al uso de sustancias de limpieza inadecuadas.

RESOLUCIÓN DE PROBLEMAS

Fallo	Causa	Solución
La luz está encendida pero el ventilador no se enciende.	El asa del ventilador está bloqueado.	Apague la unidad y repare sólo con personal de servicio calificado.
	El motor está dañado.	
Ni la luz ni el ventilador funcionan	La bombilla está quemada.	Reemplace la bombilla con una adecuada.
	Pérdidas del cable de alimentación.	Conecte nuevamente a la red.
Vibraciones graves de la unidad	El asa del ventilador está dañado. El motor del ventilador no está bien sujeto.	Apague la unidad y repare sólo con la ayuda del personal de servicio calificado.
	La unidad no está adecuadamente conectada a los soportes.	Baje la unidad y verifique que el soporte esté en una ubicación adecuada.
Rendimiento de succión insatisfactorio	Demasiada distancia entre la unidad y la superficie de succión.	Ajuste nuevamente la distancia a 65-75 cm



De acuerdo con la normativa europea 2012/19 / UE sobre residuos, este símbolo en el producto o en su embalaje indica que el producto no puede ser tratado como residuo doméstico. Por el contrario, se debe llevar al centro de recolección apropiado para el reciclaje de equipos eléctricos y electrónicos. Al asegurarse de que este producto se elimine correctamente, ayudará a prevenir posibles consecuencias negativas sobre el medio ambiente y la salud humana causadas por la manipulación inadecuada de este producto. Para obtener más detallada sobre el reciclaje de este producto, póngase en contacto con su consejo local o con el servicio recolección de residuos domésticos.

Productor

Intax Trading SRL
Calle Ion Creanga 14B, 075100, Otopeni, Ilfov, Romania
office@intaxtrading.com
www.intaxtrading.com

CONSIGNES DE SÉCURITÉ

- Merci d'avoir acheté cette hotte. Lisez attentivement le manuel d'instructions avant d'utiliser la hotte et conservez-la en lieu sûr.
- L'installation doit être effectuée par un électricien qualifié ou une personne compétente. Avant d'utiliser la hotte, assurez-vous que la tension électrique (V) et la fréquence (Hz) indiquées sur la hotte sont exactement les mêmes que la tension électrique (V) et la fréquence (Hz) de votre maison.
- Le fabricant et l'agent ne sont pas responsables des dommages causés par une installation et une utilisation incorrectes de la hotte.
- Ne laissez jamais les enfants manipuler la hotte.
- La hotte est strictement destinée à un usage domestique. Ne convient pas aux grillades, aux fast-foods et à des fins commerciales.
- La hotte et son filtre doivent être nettoyés régulièrement pour la maintenir en bon état de fonctionnement.
- Avant le nettoyage, coupez l'alimentation de la source principale.
- Nettoyez la hotte conformément au manuel d'instructions et éloignez-la du risque de brûlure.
- Il est interdit de ranger la hotte à proximité de la source d'incendie.
- En cas de défaut d'équipement, appelez le service après-vente pour demander à un technicien d'entretien.
- Cet équipement peut être utilisé par des enfants âgés de 8 ans ou plus et par des personnes ayant des capacités physiques, sensorielles et mentales réduites ou sans expérience et connaissances, si elles ont été supervisées ou instruites dans l'utilisation sûre de l'équipement et si elles comprennent les dangers encourus. Les enfants ne sont pas autorisés à jouer avec l'équipement. Le nettoyage et l'entretien ne doivent pas être effectués par des enfants sans surveillance.
- Si le cordon d'alimentation est endommagé, il doit être remplacé par le fabricant, son agent de service ou toute autre personne qualifiée afin d'éviter une situation dangereuse.
- Les instructions indiqueront ce qui suit: il y aura une ventilation adéquate de la pièce lorsque la hotte est utilisée en parallèle avec un équipement à gaz ou autre combustible (ne s'applique pas à l'équipement qui ne rejette que de l'air dans la pièce)
- Ne pas évaser sous le capot. Les parties accessibles peuvent être chauffées lorsqu'elles sont utilisées avec des appareils de cuisson.

Instructions d'installation importantes

- L'air ne doit pas être évacué vers une cheminée utilisée pour évacuer le gaz de l'équipement de gaz de combustion ou d'autres combustibles (ne s'applique pas à l'équipement qui ne rejette que de l'air dans la pièce).
- Les règles d'élimination de l'air doivent être respectées.

Remarques importantes sur la façon d'extraire



ATTENTION

Risque d'empoisonnement par les gaz d'échappement aspirés. N'utilisez jamais l'appareil en mode extraction en même temps qu'un équipement avec un panier de tirage ouvert à moins qu'une circulation d'air adéquate ne soit garantie.

L'équipement de combustion des gaz de combustion à ciel ouvert (par exemple, les appareils de chauffage au gaz, au mazout, au bois ou au charbon de bois, les chauffe-eau instantanés, les chaudières) aspire l'air de combustion de la chambre et le transporte à travers un tuyau d'échappement ou à travers une cheminée à l'extérieur. En mode d'extraction, l'air intérieur est évacué de la cuisine et des pièces adjacentes - sans suffisamment d'air, cela crée un vide. Les gaz toxiques de la cheminée ou du tirage peuvent donc être renvoyés dans les espaces de vie.

- Assurez-vous toujours que suffisamment d'air frais est fourni et qu'il peut circuler.
- Seule une alimentation en air / boîte extracteur ne peut garantir le respect de la valeur limite.

Un fonctionnement sûr n'est possible que lorsque la dépression dans la chambre où se trouve l'équipement ne dépasse pas 4 Pa (0,04 mbar). Ceci peut être réalisé lorsque l'air nécessaire à la combustion peut passer par des trous qui ne peuvent pas être fermés, par exemple des portes, des fenêtres, conjointement avec une alimentation en air / boîte extracteur ou par d'autres moyens techniques. Dans tous les cas, consultez un ramoneur qualifié qui pourra évaluer l'ensemble de la ventilation de votre maison et qui pourra vous proposer des mesures appropriées pour une ventilation adéquate.

Si la hotte est utilisée exclusivement en mode de recirculation, il est possible de fonctionner sans restriction.



ATTENTION

Risque d'incendie par étincelles. N'installez l'équipement sur un foyer à combustible solide (p. Ex. Bois ou charbon de bois) que si un couvercle fermé et non amovible est disponible.

DIMENSIONS

Model No.: THEA - Product Code TH50RCB, TH50RC

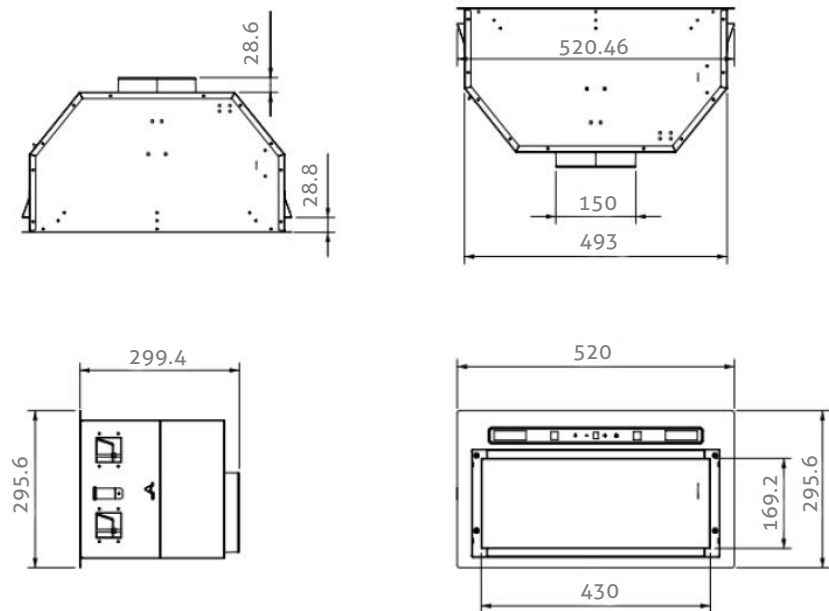

DIMENSIONS

Model No.: THEA 75 - Product Code TH75RCB, TH75RC

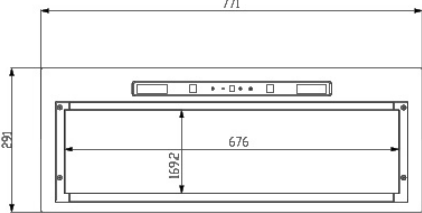
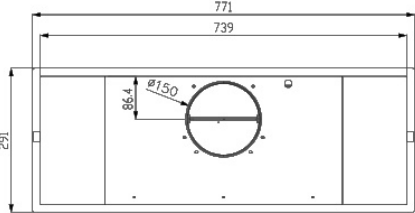
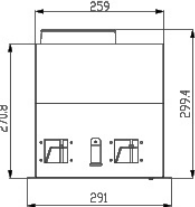
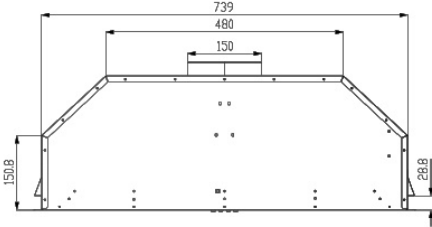

INSTALLATION

Remarque: Lorsque la hotte et l'équipement alimenté par une alimentation non électrique fonctionnent simultanément, la pression négative dans la pièce ne doit pas dépasser 4 Pa (4 x 10⁻⁵ Bar).

Distance minimale requise entre la hotte envers

Anneaux en verre céramique/plaques	65 cm
Cuisinière à gaz	75 cm
Table de cuisson bois / charbon / huile 85 cm	85 cm

ÉTAPES D'INSTALLATION

Remarque: Ne branchez pas le cordon d'alimentation tant que l'installation n'est pas terminée! Appelez une deuxième personne pour aider à l'installation.

1. Découpez un trou dans le mur de l'armoire sous lequel la hotte sera montée. Utilisez les dimensions suivantes comme guide:

MESURES D'ORIFIGATION POUR L'INSTALLATION (mm)

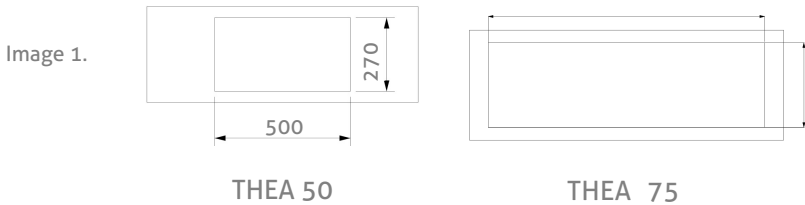

2. Insérez la hotte dans l'armoire. Assurez-vous que les clips élastiques des deux côtés sont fixés à l'armoire.

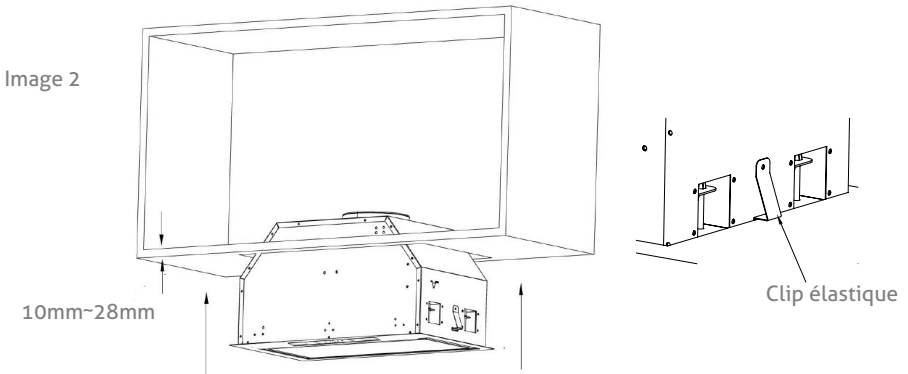

3. Retirez le filtre à graisse métallique

Image 3.

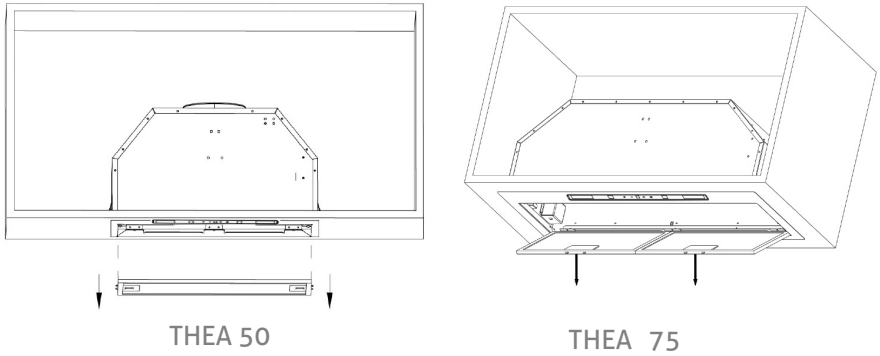

4. Ajustez les vis 1. 2. 3. 4. jusqu'à ce que les brides des deux côtés soient fixées à l'armoire comme dans la Figure 5.

Image 4.

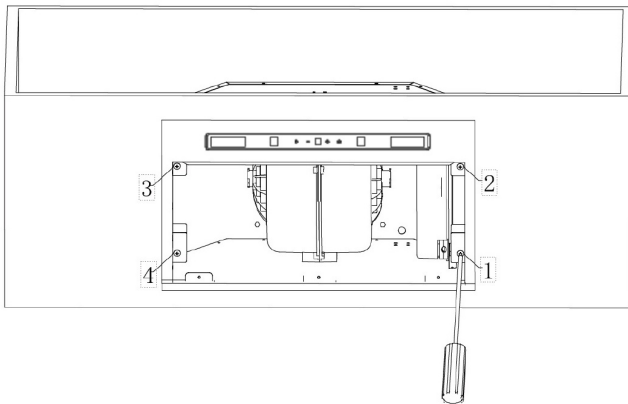
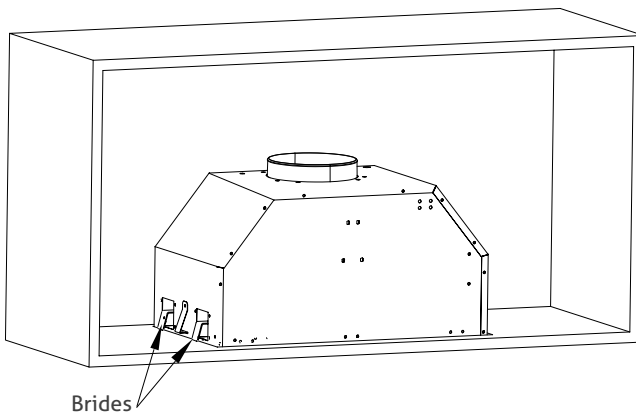

Image 5.



5. Réinstallez le filtre à graisse métallique (Figure 6) et terminez l'installation (Figure 7).

Image 6.

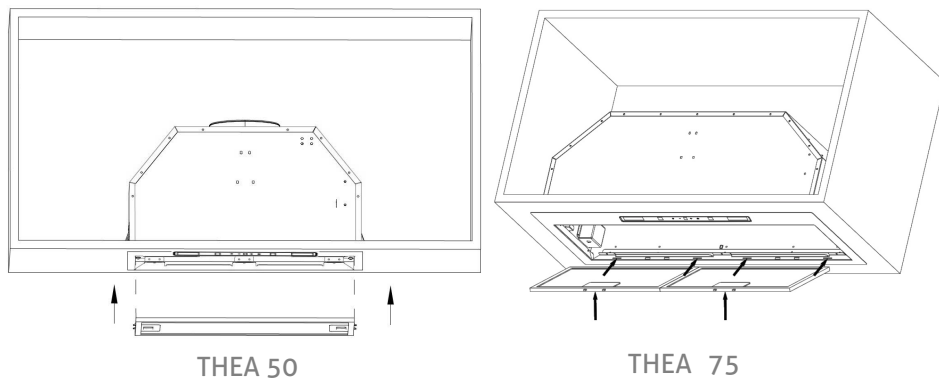
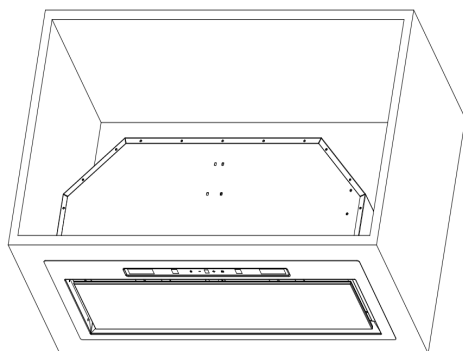
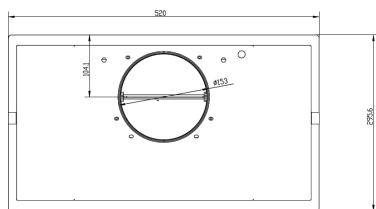

Image 7.



6. La taille de l'alimentation en air.

THEA - Product Code TH50RCB, TH50RC



THEA 75 - Product Code TH75RCB, TH75RC

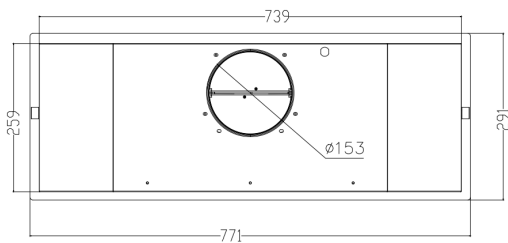

7. Installation de la vanne d'arrêt (figure 8), du tuyau d'aspiration (figure 9) et du raccordement électrique (figure 10).

Model No.: THEA - Product Code TH50RCB, TH50RC

Image 8(1)

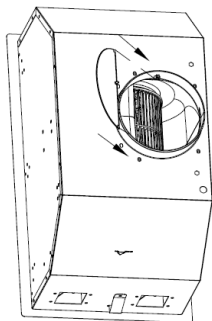

Image 8(2)

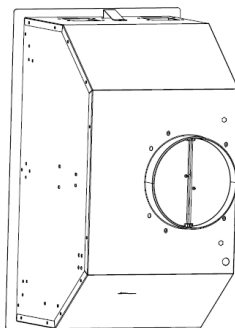

Image 9

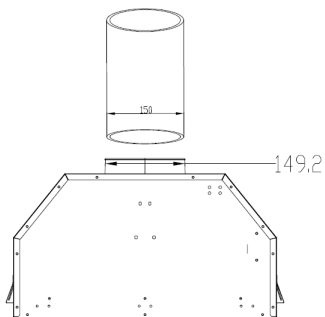
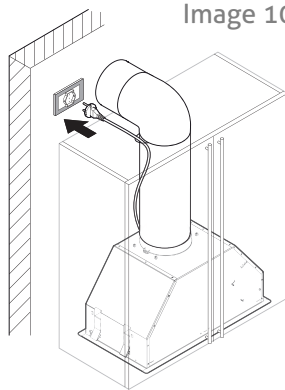
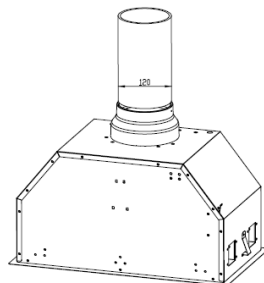
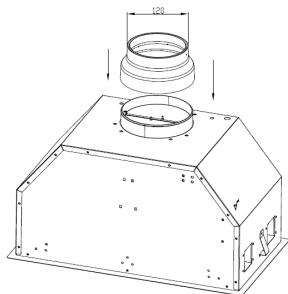

Image 10



8. Installez l'adaptateur d'admission d'air



9. Installation du filtre charbon - **CODE: TCF1** (non inclus)

Model No.: THEA - Product Code TH50RCB, TH50RC

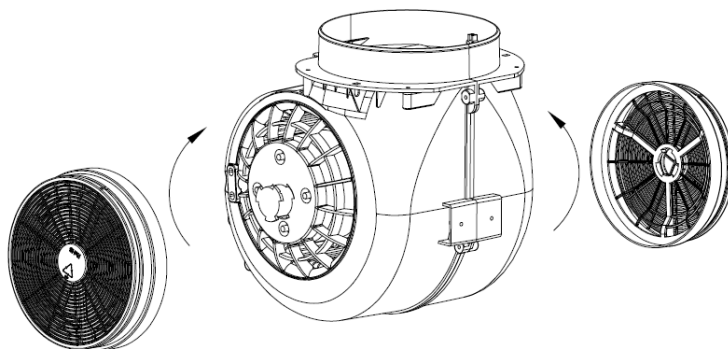

THEA - Product Code TH50RCB, TH50RC

Données techniques

	Valeur	Unité
Capacité du moteur	800	m ³ /h
Débit d'air maximal de la hotte - Boost	607	m ³ /h
Débit d'air de la hotte au point de fonctionnement - élevé	542	m ³ /h
Débit d'air de la hotte au point de fonctionnement - faible	344	m ³ /h
Puissance électrique	124	W
Puissance nominale du système d'éclairage	4	W
Niveau de puissance sonore - boost	67	dB
Niveau de puissance sonore - élevé	65	dB
Niveau de puissance sonore - faible	55	dB
Classe d'efficacité énergétique	A+	
Consommation d'énergie annuelle	23.4	kWh/a
Diamètre de connexion - Minime/ Optimale	120/150	mm

THEA 75 - Product Code TH75RCB, TH75RC

Données techniques

	Valeur	Unité
Capacité du moteur	800	m ³ /h
Débit d'air maximal de la hotte - Boost	692	m ³ /h
Débit d'air de la hotte au point de fonctionnement - élevé	613	m ³ /h
Débit d'air de la hotte au point de fonctionnement - faible	313	m ³ /h
Puissance électrique	125	W
Puissance nominale du système d'éclairage	5	W
Niveau de puissance sonore - boost	66	dB
Niveau de puissance sonore - élevé	65	dB
Niveau de puissance sonore - faible	50	dB
Classe d'efficacité énergétique	A++	
Consommation d'énergie annuelle	27.2	kWh/a
Diamètre de connexion - Minimale/ Optimale	120/150	mm

THEA 50/ 75 - FONCTIONS

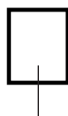

Capteur de gestes



Écran d'affichage



Capteur de gestes



Bouton marche/arrêt - utilisé pour démarrer/arrêter l'appareil



Bouton d'augmentation de la vitesse - Pour ajuster le booster, maintenez cette touche appuyée, l'appareil reviendra à la 3ème vitesse après avoir fonctionné pendant 5 minutes dans ce mode.



Bouton de réduction de la vitesse - Pour réduire la vitesse





Bouton d'éclairage



Affichage numérique - Affichage de la vitesse : "1" pour la basse vitesse, "2" pour la vitesse moyenne, "3" pour la haute vitesse, "B" pour le booster, "C" pour la fonction de nettoyage de l'air.

Fonction Quick Timer: Appuyez simultanément sur les touches **+** et **-** pendant 1 seconde. L'affichage intermittent et l'arrêt automatique de l'appareil sont activés après 5 minutes. Au bout de 5 minutes, le moteur s'arrête et, si aucune autre fonction n'est activée, un signal sonore retentit pendant 5 secondes. Pendant le signal sonore, il peut être arrêté en appuyant sur n'importe quelle touche. Vous pouvez désactiver la fonction Quick Timer en appuyant à nouveau simultanément sur les touches **+** **-**

Fonction de nettoyage de l'air

En mode veille, appuyez longuement sur le bouton  pendant 3 secondes pour accéder à la fonction de nettoyage de l'air ; cette fonction permet à l'appareil de fonctionner à basse vitesse pendant 5 minutes, après quoi il s'éteint automatiquement pendant 55 minutes. Après 55 minutes, l'appareil se rallume automatiquement pendant 5 minutes puis s'éteint à nouveau pendant 55 minutes. "C" s'affiche sur l'écran pendant le fonctionnement à basse vitesse. Une fois cette fonction activée, elle ne peut être désactivée qu'en appuyant à nouveau sur la touche ON pendant 1 seconde, sans affecter les autres opérations normales activées (la touche  clignote lors de l'entrée dans la fonction de nettoyage de l'air).





CONNEXION DE LA TÉLÉCOMMANDE

En mode veille, appuyez longuement sur le bouton  pendant 3 secondes pour entrer dans le mode de synchronisation de la télécommande, le voyant continue de clignoter.

En mode synchronisation, appuyez sur le bouton  de la télécommande et un signal sonore retentira, la télécommande s'est connectée avec succès. Si aucune opération n'est effectuée ou si la synchronisation échoue après 15 secondes, le système revient en mode veille.



Utilisation de la télécommande

-  **Bouton marche/arrêt** - Utilisé pour démarrer/arrêter l'appareil.
-  **Bouton d'augmentation de la vitesse** - Pour ajuster "le booster", maintenez cette touche appuyée ; le ventilateur se remettra en marche en 3ème vitesse après avoir fonctionné pendant 5 minutes en mode "booster".
-  **Bouton de réduction de la vitesse** - Pour réduire la vitesse
-  **Buton d'éclairage**



Contrôle par des gestes

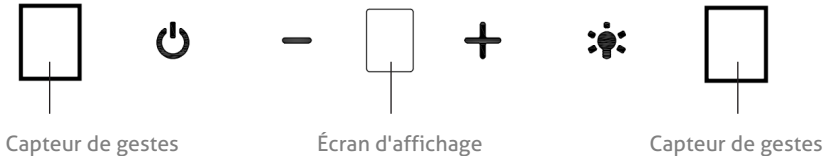

Cette fonction est disponible si l'appareil est en mode veille.

Les détecteurs de mouvement sont activés en passant la main de gauche à droite ou vice versa à travers le panneau de commande.

- Déplacer la main de gauche à droite augmente le niveau de vitesse. A partir du mode boost, le même mouvement provoque le retour à la vitesse minimale.
- Le passage de la main de droite à gauche, fonction disponible uniquement lorsque le moteur de l'appareil est allumé, le fait entrer en mode **Quick Timer**, après quoi il s'arrêtera au bout de 5 minutes. A partir du mode Quick Timer, le même mouvement provoque l'arrêt immédiat de l'appareil.

Le niveau de vitesse réglé suite à la commande gestuelle sera affiché en permanence sur l'afficheur. En mode Quick Timer, le niveau de vitesse sera affiché par intermittence.

NETTOYER LES SURFACES EN ACIER INOXYDABLE

Pour éviter d'endommager la surface en acier inoxydable de votre appareil

Nettoyez toujours avec :

Chiffons doux, eau distillée ou filtrée, ainsi que détergents spécialement conçus pour l'inox.

Ne pas nettoyer avec :

Matériaux abrasifs, poudres de nettoyage, eau de Javel et autres produits à base de chlore, nettoyeurs pour vitres contenant de l'ammoniac, eau du robinet, surtout si elle a tendance à être dure, nettoyeurs pour four.

Les dommages aux surfaces en acier inoxydable dus à l'utilisation de produits de nettoyage inappropriés ne sont pas couverts par la garantie.

DÉPANNAGE

Echec	Cause	Solution
La luce è accesa, ma la ventola non funziona.	La ventola è inceppata.	Spegnere l'unità e farla riparare solo da un tecnico qualificato.
	Il motore è danneggiato.	
Ni la lumière ni le ventilateur ne fonctionnent.	Ampoule brûle.	Remplacez l'ampoule par une ampoule appropriée.
	Le cordon d'alimentation fuit.	Remettez le courant sous tension.
Graves vibrations de l'appareil	La pale du ventilateur est endommagée.	Éteignez l'appareil et réparez uniquement avec du personnel qualifié.
	Le moteur du ventilateur n'est pas solidement fixé.	Abaissez l'unité et vérifiez que le support est dans un endroit approprié.
Performances d'aspiration insatisfaisantes	Trop de distance entre l'appareil et la surface de cuisson.	Ajustez à nouveau la distance à 65-75 cm.



Conformément à la réglementation européenne sur les déchets 2012/19 / UE, ce symbole sur le produit ou sur son emballage indique que le produit ne peut pas être traité comme déchet ménager. Au contraire, il doit être acheminé vers le centre de collecte approprié pour le recyclage des équipements électriques et électroniques. En vous assurant que ce produit est mis au rebut correctement, vous contribuerez à éviter les effets néfastes sur l'environnement et la santé humaine causés par une mauvaise manipulation de ce produit. Pour plus d'informations sur le recyclage de ce produit, veuillez contacter votre mairie ou votre service d'élimination des déchets ménagers.

Producteur

Intax Trading SRL
Ion Creanga 14B, 075100, Otopeni, Ilfov, Romania
office@intaxtrading.com
www.intaxtrading.com

ISTRUZIONI DI SICUREZZA

- Grazie per aver acquistato questa cappa aspirante. Si prega di leggere attentamente il manuale di istruzioni prima di utilizzare la cappa aspirante e conservarla in un luogo sicuro.
- I lavori di installazione devono essere eseguiti da un elettricista qualificato o da una persona competente. Prima di utilizzare la cappa, assicurarsi che la tensione (V) e la frequenza (Hz) indicate sulla cappa sono esattamente gli stessi della tensione (V) e la frequenza (Hz) in casa.
- Il produttore e l'agente non si assumono alcuna responsabilità per i danni causati da installazione e utilizzo inappropriati.
- Non permettere mai ai bambini di utilizzare la cappa aspirante.
- Utilizzare la cappa aspirante esclusivamente per il normale uso domestico. Non è adatta per barbecue, roast shop e uso commerciale.
- La cappa aspirante e la sua rete filtrante devono essere pulite regolarmente per mantenerla in buone condizioni di lavoro.
- Prima di effettuare pulizia, disinserire obbligatoriamente l'alimentazione elettrica (estrarre il cavo di alimentazione dalla presa elettrica).
- Pulire la cappa secondo il manuale di istruzioni e proteggerla dal pericolo di incendio.
- Non posizionare la cappa vicino al fuoco.
- In caso di guasti all'apparecchio, contattare il servizio di assistenza per richiedere l'aiuto di un tecnico.
- Questo apparecchio può essere utilizzato da bambini di età pari o superiore a 8 anni e da persone con capacità fisiche, sensoriali o mentali ridotte o senza esperienza e conoscenza se sono stati sottoposti a supervisione o istruzione relative all'uso dell'apparecchio in modo sicuro e comprendono pericoli coinvolti. I bambini non devono giocare con l'apparecchio. La pulizia e la manutenzione dell'unità non devono essere eseguite da bambini.
- Se il cavo di alimentazione è danneggiato, deve essere sostituito dal produttore, dal suo agente di servizi o da persone analogamente qualificate per evitare pericoli
- Le istruzioni devono indicare la sostanza di quanto segue: deve esserci un'adeguata ventilazione nella stanza quando la cappa viene utilizzata contemporaneamente ad apparecchi a gas o altri combustibili (non applicabile agli apparecchi che solo scaricano l'aria nella stanza).
- Non fiammeggiare sotto la cappa. Le parti accessibili possono surriscaldarsi se utilizzate con apparecchi di cottura.

Suggerimenti importanti per l'installazione

- L'aria non deve essere scaricata in una canna fumaria utilizzata per scaricare i fumi dagli apparecchi che bruciano gas o altri combustibili (non applicabile agli apparecchi che scaricano l'aria nella stanza).
- Devono essere rispettate le norme relative allo scarico dell'aria.

Note importanti sulla modalità di estrazione



Rischio di avvelenamento derivante dai gas di scarico rilasciati nella stanza. Non mettere mai in funzione il dispositivo in modalità di estrazione contemporaneamente a un apparecchio a camino aperto quando non è garantito un flusso d'aria adeguato.

Le apparecchiature a gas a camera aperta (ad esempio scaldabagni a gas, a petrolio, a legna o a carbone, scaldabagni senza serbatoio, scaldabagni) aspirano l'aria di combustione dalla stanza e la fanno passare attraverso un tubo di scarico o un camino verso l'esterno. Nella modalità di estrazione, l'aria interna viene rimossa dalla cucina e dalle stanze adiacenti – senza una presa d'aria sufficiente questo crea un vuoto. I gas tossici provenienti dal camino o dalla canna fumaria di estrazione possono quindi essere rilasciati negli spazi abitativi.

- Assicurarsi sempre che sia garantita una quantità sufficiente di aria fresca e che possa circolare.
- Una sola scatola di alimentazione / estrazione dell'aria non garantisce il rispetto del valore limite.

Il funzionamento sicuro è possibile solo quando la pressione negativa nella stanza in cui si trova l'apparecchio non supera i 4 Pa (0,04 mbar). Ciò può essere ottenuto quando l'aria necessaria per la combustione può fluire attraverso aperture non richiudibili, ad esempio porte, finestre, insieme a una scatola di alimentazione / estrazione dell'aria o attraverso altri sistemi tecnici. In ogni caso, consultare uno spazzacamino qualificato in grado di valutare l'intera ventilazione della propria casa e proporre misure appropriate per un'adeguata ventilazione. Se la cappa viene utilizzata esclusivamente in modalità di ricircolo, è possibile l'operazione senza restrizioni.



AVVERTIMENTO

Pericolo di incendio a causa di scintille. Installare l'apparecchiatura su un caminetto per combustibili solidi (ad esempio legna o carbone), solo se è disponibile una copertura chiusa non rimovibile.

DIMENSIONI

Model No.: THEA - Product Code TH50RCB, TH50RC

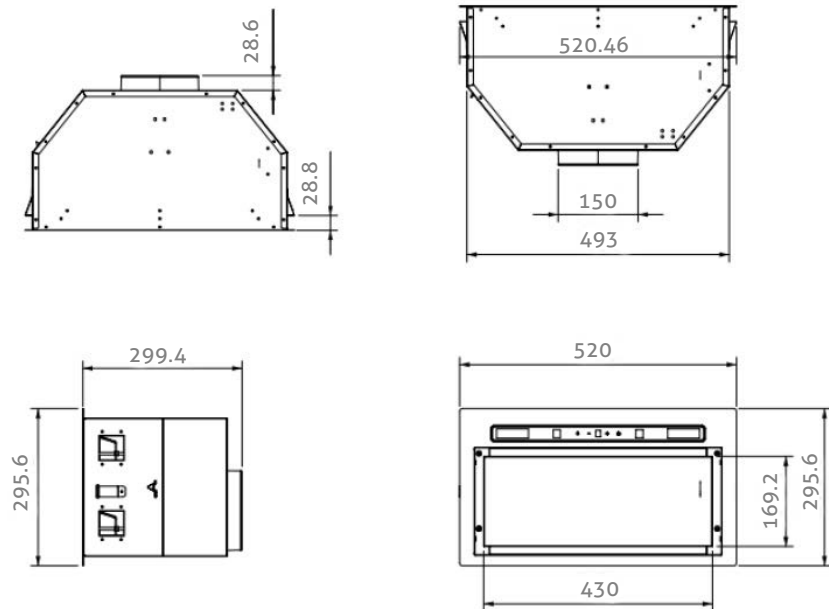

DIMENSIONI

Model No.: THEA 75 - Product Code TH75RCB, TH75RC

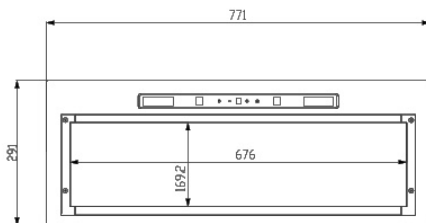
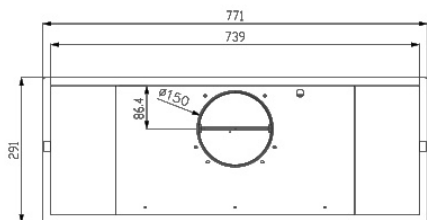
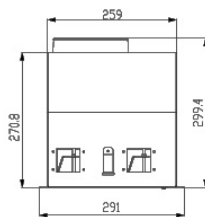
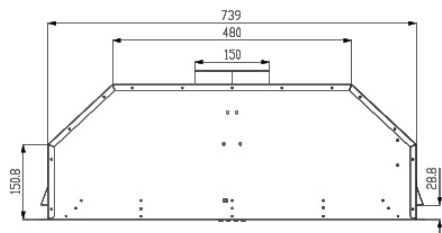

INSTALLAZIONE

Nota: quando la cappa e l'apparecchio alimentati con energia diversa dall'elettricità sono contemporaneamente in funzione, la pressione negativa nella stanza non deve superare i 4 Pa (4×10^{-5} Bar).

Distanza minima necessaria tra la cappa e:

Anelli / piastre di cottura in vetroceramica	65 cm
Fornello a gas	75 cm
Stufa a legna / carbone / petrolio	85 cm

Procedura di installazione

Nota: non collegare il cavo di alimentazione fino al completamento dell'installazione! Ottieni una seconda persona che ti aiuti con l'installazione. Chiedi a un'altra persona di aiutarti con l'installazione.

1. Segna un'apertura nel pensile sotto il quale deve essere montata la cappa. Utilizzare le seguenti dimensioni come guida:

DIMENSIONE E POSIZIONE DEI FORI NECESSARI PER L'INSTALLAZIONE (mm)

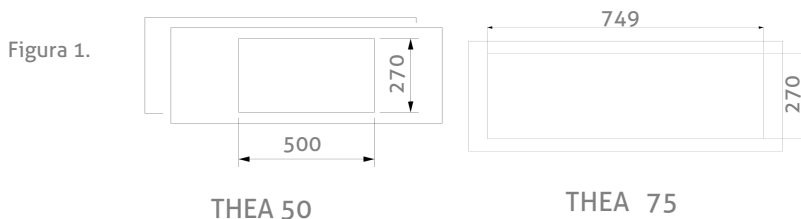

2. Inserire la cappa nel pensile. Assicurarsi che i perni elastici di entrambi i lati siano fissati sul pensile.

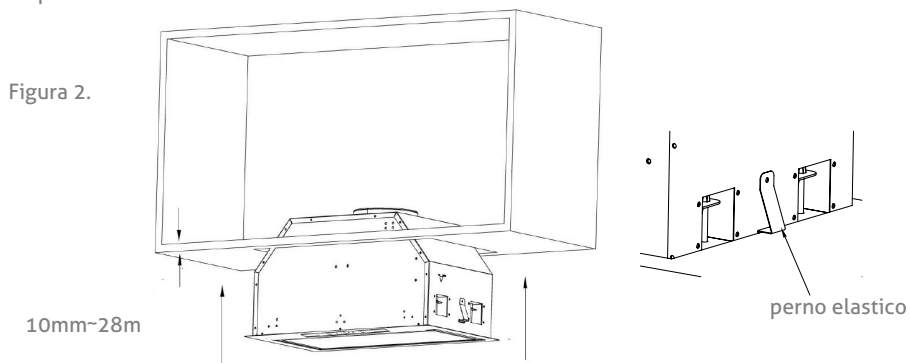

3. Filtro antigrasso metallico

Figura 3.

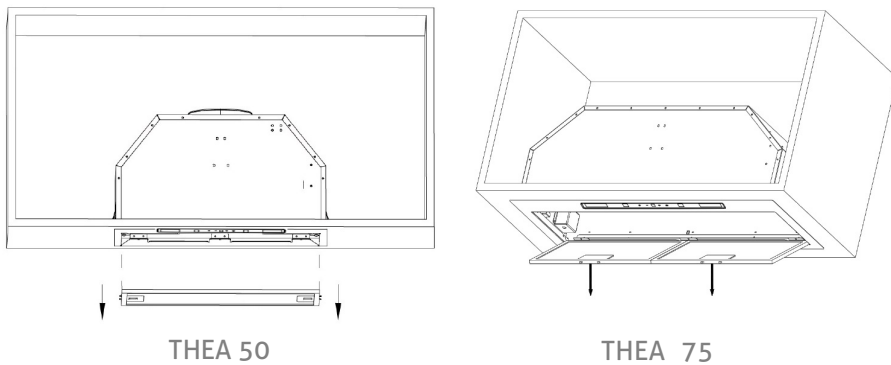

4. Regolare le viti 1. 2. 3. 4. fino a quando le flange di entrambi i lati sono fissate sul pensile come mostrato nella figura 5.

Figura 4.



Figura 5.



5. Reinstallare il filtro antigrasso metallico (Figura 6) e completare l'installazione (Figura 7).

Figura 6.

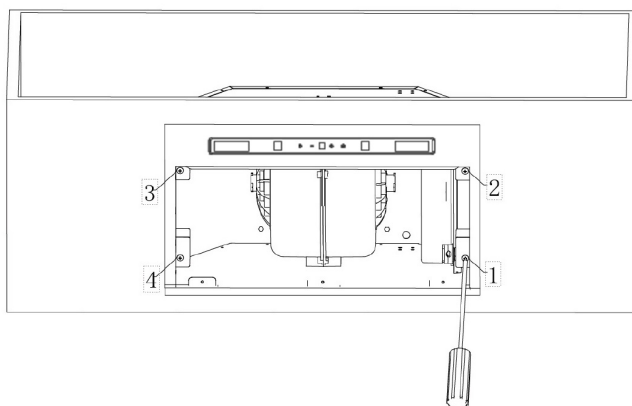
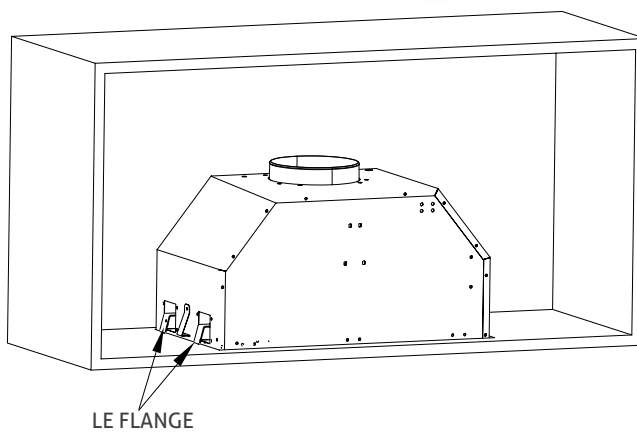

Figura 7.



6. La dimensione del condotto

THEA - Product Code TH50RCB, TH50RC

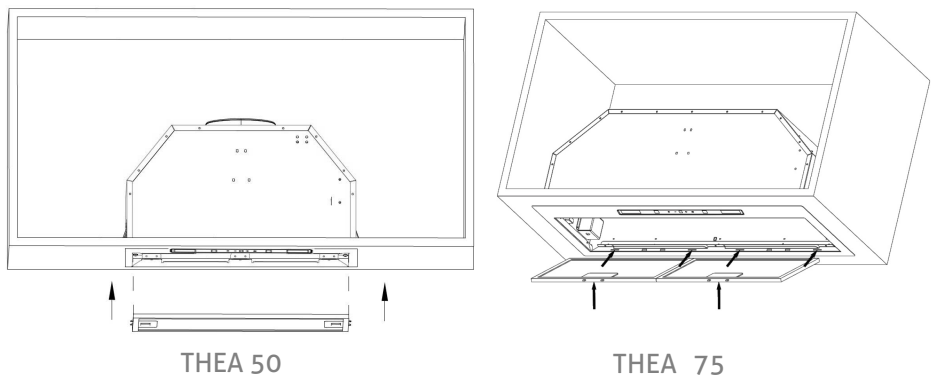
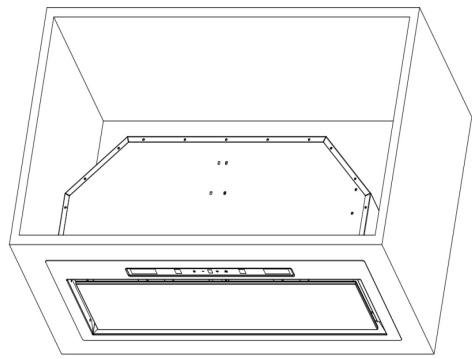
THEA 75 - Product Code TH75RCB, TH75RC

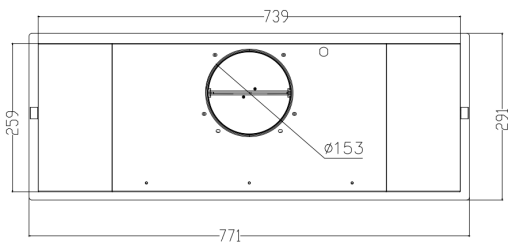
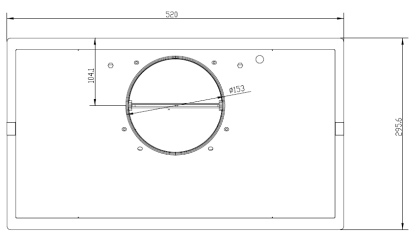

7. Installazione di valvola di ritegno (Figura 8), tubo di aspirazione, (Figura 9) e collegamento elettrico (Figura 10)

Model No.: THEA - Product Code TH50RCB, TH50RC

Figura 8(1).



Figura 8(2).



Figura 9.

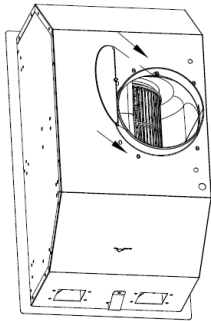

Figura 10.

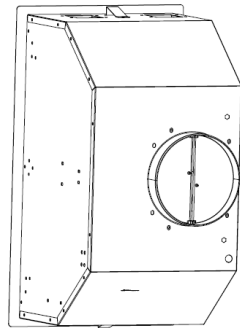

8. Installazione dell'adattatore per condotto

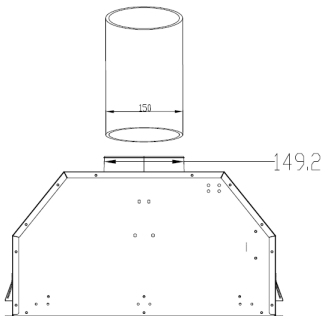
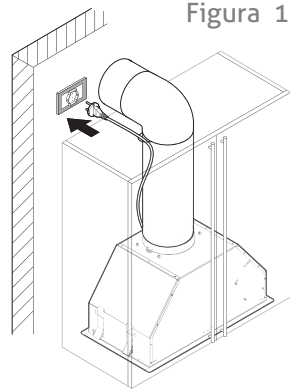
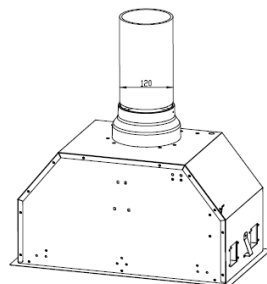
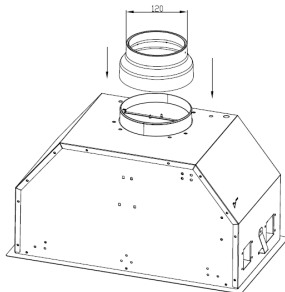

9. Installazione del filtro a carbone - **Code: TCF1** (non incluso).

Model No.: THEA 50/ 50 BLACK - product Code TH50RCB, TH50RC

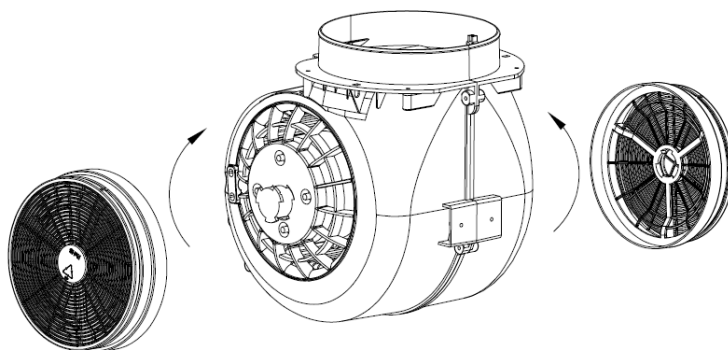

THEA - Product Code TH50RCB, TH50RC

Dati tecnici

	Valore	Unità
Capacità del motore	800	m ³ /h
Massimo flusso d'aria della cappa - boost	607	m ³ /h
Flusso d'aria della cappa nel punto di lavoro - alto	542	m ³ /h
Flusso d'aria della cappa nel punto di lavoro - basso	344	m ³ /h
Potenza elettrica assorbita	124	W
Potenza nominale del sistema di illuminazione	4	W
Livello di potenza sonora - boost	67	dB
Livello di potenza sonora - alto	65	dB
Livello di potenza sonora - basso	55	dB
Classe di efficienza energetica	A+	
Consumo energetico annuale	23.4	kWh/a
Diametro di connessione - Minimo/ Ottimo	120/ 150	mm

THEA 75 - Product Code TH75RCB, TH75RC

Dati tecnici

	Valore	Unità
Capacità del motore	800	m ³ /h
Massimo flusso d'aria della cappa - boost	692	m ³ /h
Flusso d'aria della cappa nel punto di lavoro - alto	613	m ³ /h
Flusso d'aria della cappa nel punto di lavoro - basso	313	m ³ /h
Potenza elettrica assorbita	125	W
Potenza nominale del sistema di illuminazione	5	W
Livello di potenza sonora - boost	66	dB
Livello di potenza sonora - alto	65	dB
Livello di potenza sonora - basso	50	dB
Classe di efficienza energetica	A++	
Consumo energetico annuale	27.2	kWh/a
Diametro di connessione - Minimo/ Ottimo	120/150	mm

THEA 50/ 75 - FUNZIONI

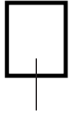

Sensore gesti



Schermo di visualizzazione

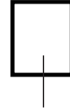

Sensore gesti



Pulsante On/Off - utilizzato per avvio/arresto unità



Pulsante incremento velocità - Per l'impostazione booster premere a lungo questo pulsante, ritornerà a velocità 3 dopo aver funzionato in questo modo per 5 minuti.



Pulsante decremento velocità - Per ridurre la velocità



Pulsante illuminazione





Schermo digitale - Visualizzazione velocità: "1" per velocità ridotta, "2" per velocità media, "3" per velocità alta, "B" per booster, "C" per la funzione di pulizia dell'aria.

Funzione Quick Timer

Premere simultaneamente i pulsanti più **+** e meno **-** per 1 secondo. La visualizzazione intermittente e l'arresto automatico dell'unità vengono attivati dopo 5 minuti. Dopo 5 minuti, il motore si arresterà, e se non verrà attivata un'altra funzione, si sentirà un segnale acustico per 5 secondi. Durante il funzionamento del segnale acustico, lo stesso può essere spento premendo qualsiasi pulsante. La funzione Quick Timer può essere disattivata premendo nuovamente i pulsanti **+** **-**

Funzione per la pulizia dell'aria

Nella modalità standby premere a lungo  per 3 secondi per accedere alla funzione di pulizia dell'aria; questa funzione permette il funzionamento dell'unità a velocità ridotta per 5 minuti, dopodiché si arresta automaticamente per 55 minuti. Dopo 55 minuti, l'unità si avvia automaticamente per altri 5 minuti dopodiché si arresta di nuovo per 55 minuti.

Durante il funzionamento a velocità ridotta, sullo schermo, viene visualizzato "C". Dopo l'avvio di questa funzione, la stessa può essere arrestata soltanto premendo di nuovo il pulsante ON per 1 secondo, senza incidere su altre operazioni normali attivate (il tasto  lampeggia all'avvio della funzione di pulizia dell'aria).





COLLEGAMENTO TELECOMANDO

Nella modalità standby premere a lungo il pulsante  per 3 secondi per accedere alla modalità di sincronizzazione del telecomando, la lampada indicante continua a lampeggiare.

Nella modalità sincronizzazione, premere il pulsante  del telecomando; scatterà un segnale acustico, indicando che il telecomando è stato collegato con successo. Se non viene effettuata nessuna operazione o se la sincronizzazione fallisce, dopo 15 secondi, il sistema ritorna allo stato di standby.



Utilizzo del telecomando

-  **Pulsante On/Off (avvio/arresto)** - Utilizzato per avvio/arresto unità.
-  **Pulsante incremento velocità** - Per l'impostazione "booster" premere a lungo questo tasto; il ventilatore ritornerà a funzionare in terza velocità dopo aver funzionato per 5 minuti nella modalità "booster".
-  **Pulsante decremento velocità** - Per ridurre la velocità
-  **Pulsante illuminazione**

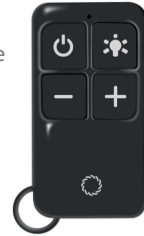

Controllo tramite gesti

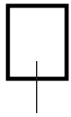

Sensore gesti

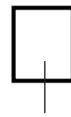

Schermo di visualizzazione

Sensore gesti

Questa funzione è disponibile se l'unità è in modalità standby.

I sensori di movimento si attivano passando la mano da sinistra a destra o viceversa attraverso il pannello di controllo.

1. Muovendo la mano da sinistra a destra aumenta il livello di velocità. Dalla modalità boost, lo stesso movimento provoca il ritorno alla velocità minima.
2. Passando la lancetta da destra a sinistra, funzione disponibile solo a motore acceso, l'unità entra in modalità **Quick Timer**, dopodiché si arresta dopo 5 minuti. Dalla modalità Quick Timer, lo stesso movimento provoca l'arresto immediato dell'unità.

Il livello di velocità impostato come risultato del controllo gestuale verrà visualizzato in modo permanente sul display. In modalità Quick Timer, il livello di velocità verrà visualizzato in modo intermittente.

PULIZIA DELLE SUPERFICI IN ACCIAIO INOX

Per evitare di danneggiare la superficie in acciaio inossidabile del vostro apparecchio

Pulisci sempre con:

Panni morbidi, acqua distillata o filtrata, nonché detersivi specifici per acciaio inossidabile.

Non pulire con:

Materiali abrasivi, polveri detergenti, candeggina e altri prodotti a base di cloro, detergenti per vetri contenenti ammoniaca, acqua del rubinetto soprattutto se tendenzialmente dura, detergenti per forni

I danni alle superfici in acciaio inossidabile dovuti all'uso di detergenti impropri non sono coperti dalla garanzia.

RISOLUZIONE DEI PROBLEMI

Guasto	Causa	Soluzione
La luce è accesa, ma la ventola non funziona.	La ventola è inceppata.	Spegnerne l'unità e farla riparare solo da un tecnico qualificato.
	Il motore è danneggiato.	
Sia la luce che la ventola non funzionano.	La lampadina è bruciata.	Sostituire la lampadina con una nuova con le stesse caratteristiche.
	Il cavo di alimentazione non è inserito correttamente.	Inserire nuovamente il cavo di alimentazione correttamente.
L'unità vibra fortemente	La pala della ventola è danneggiata. Il motore del ventilatore non è fissato saldamente.	Spegnerne l'unità e farla riparare solo da un tecnico qualificato
	L'unità non è fissata correttamente alla staffa.	Smontare l'unità e verificare se la staffa è in una posizione corretta.
Le prestazioni di aspirazione sono scarse	Distanza troppo lunga tra l'unità e il piano di cottura	Regolare la distanza 65-75cm

SUGGERIMENTI SULLO SMALTIMENTO



In conformità alla Direttiva Europea 2012/19/UE il simbolo sul prodotto o sulla documentazione di accompagnamento indica che questo prodotto non deve essere trattato come rifiuto domestico, ma deve essere consegnato presso l'idoneo punto di raccolta per il riciclaggio di apparecchiature elettriche ed elettroniche. Provvedendo al corretto smaltimento del prodotto si contribuirà ad evitare potenziali effetti negativi sull'ambiente e sulla salute umana. Per ulteriori informazioni sul trattamento, il recupero e il riciclaggio degli elettrodomestici, contattare l'ufficio locale competente, il servizio di raccolta dei rifiuti domestici o il negozio presso il quale il prodotto è stato acquistato.

Produttore

Intax Trading SRL
Via Ion Creanga 14B, 075100, Otopeni, Ilfov, Romania
office@intaxtrading.com
www.intaxtrading.com

