

UPUTSTVO ZA MONTIRANJE
ASSEMBLING INSTRUCTION
MONTAGEANLEITUNG
INSTRUCTIONS D'ASSEMBLAGE
INSTRUCCIONES DE MONTAJE

ISTRUZIONI PER L'INSTALLAZIONE
ИНСТРУКЦИЯ ПО МОНТАЖУ
MONTÁŽNÍ NÁVOD
ΟΔΗΓΙΕΣ ΣΥΝΑΡΜΟΛΟΓΗΣΗΣ
INSTRUCCIUNI DE MONTAJ

ИНСТРУКЦИЯ ЗА МОНТАЖ
SZERELÉSI UTASÍTÁS
NAVODILA ZA MONTAŽO
UPUTE ZA MONTAŽU
UPUTSTVO ZA MONTIRANJE

УПАТСТВО ЗА МОНТИРАЊЕ
UDHËZIMET PËR MONTIM
INSTRUKCJA MONTAŻU
INSTRUÇÕES DE MONTAGEM

DALILA 120

CODE: UP 01082
Version: 01-19032020

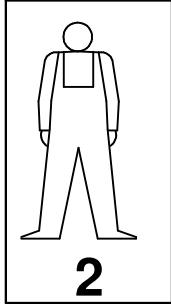

2

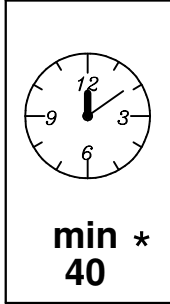

min *
40

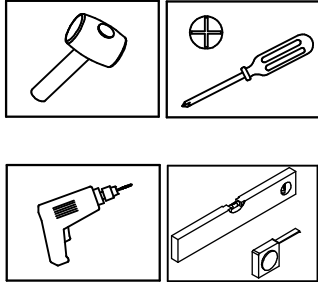

* **RS ME** Naznačeno vreme montaže važi za stručno obučena lica (profesionalne montažere)/**UK** The specified installation time applies to professionally trained persons (professional installers)/**DE AT CH** Die bezeichnete Zeit der Montage gilt für fachlich geschulte Personen (professionelle Monteure) / **FR CH** Le temps d'installation spécifié s'applique aux personnes formées professionnellement (installateurs professionnels) / **ES** El tiempo de instalación especificado se refiere a personas profesionalmente capacitadas (instaladores profesionales) / **IT CH** tempo di installazione indicato vale per le persone professionalmente preparate (installatori professionali) / **RUS** Приведённое время монтажа действительно для специально обученных лиц (профессиональных монтажников) / **CZ** Uvedená doba montáže se vztahuje na odborné zručné osoby (profesionální montér) / **EL** Ο αναφερόμενος χρόνος εγκατάστασης ισχύει για εκπαιδευμένα άτομα (επαγγελματίες εγκαταστάτες) / **RO** Timpul de instalare specificat se aplică persoanelor instruite profesional (instalatori profesioniști) / **BG** Посоченото време за монтаж се отнася за професионално обучени лица (професионални монтажници) / **HU** Az összeszerelés megjelölt ideje a szakképzett személyekre vonatkozik (hivatásos összeszerelők) / **SL** Navedeni čas namestitve (montaže) velja za strokovno usposobljene osebe (strokovne monterje) / **HR** Navedeno vrijeme montaže odnosi se na stručno osposobljene osobe (profesionalne montažere) / **BIH** Naznačeno vrijeme montaže važi za stručno obučena lica (profesionalne montažere) / **MK** Назначено време за монтажа важи за стручно обучени лица (професионални монтажери) / **AL** Koha e specifikuar e instalimit zbatohet në rast të personave me trajnim profesional (instalues profesionistë) / **PL** Znacznony czas montażu dotyczy przeszkolonych zawodowo osób (profesjonalnych monterów). / **PT** O tempo de montagem indicado aplica-se a pessoas profissionalmente treinadas (instaladores profissionais)

RS ME PRE POČETKA MONTIRANJA OBAVEZNO PROČITAJTE UPUTSTVO ZA MONTAŽU / **UK** BEFORE STARTING, REFER TO THE ASSEMBLING ADVICE IN ANNEX / **DE AT CH** VOR DER MONTAGE BITTE BEILIEGENDE ANWEISUNGEN LESEN / **FR CH** AVANT LE DÉBUT DE L'ASSEMBLAGE, S'IL VOUS PLAÎT, LISEZ L'INSTRUCTION D'ASSEMBLAGE / **ES** ANTES DE EMPEZAR EL MONTAJE, LEER CUIDADOSAMENTE LAS INSTRUCCIONES DEL ANEXO / **IT CH** PRIMA DI INIZIARE L'INSTALLAZIONE SI RACCOMANDA DI LEGGERE LE ISTRUZIONI DI INSTALLAZIONE / **RUS** ДО НАЧАЛА МОНТАЖА ОЗНАКОМЬТЕСЬ С ИНСТРУКЦИЕЙ / **CZ** SEZNAMTE SE S NÁVODEM PŘED MONTÁŽÍ NÁBYTKU / **EL** ΠΡΙΝ ΞΕΚΙΝΗΣΕΤΕ ΤΗ ΣΥΝΑΡΜΟΛΟΓΗΣΗ, ΟΠΩΣΔΗΠΟΤΕ ΔΙΑΒΑΣΤΕ ΤΙΣ ΟΔΗΓΙΕΣ ΣΥΝΑΡΜΟΛΟΓΗΣΗΣ / **RO** ÎNAINTE DE ÎNCERPEA MONTAJULUI ESTE OBLIGATORIE CITIREA INSTRUCȚIUNILOR / **BG** ПРЕДИ МОНТИРАНЕ НЕ ЗАБРАВЯЙТЕ ДА СК ЧЕТЕ ИНСТРУКЦИИ ЗА МОНТАЖ / **HU** SZERELÉS ELŐTT OKVETLENŰL OLVASSA EL A HASZNÁLATI UTASÍTÁST / **SL** PRED ZAČETKOM MONTAŽE OBAVEZNO PREBERITE NAVODILA / **HR** PRIJE MONTAŽE UPOZNATI SE SA UPUTSTVOM / **BIH** PRE POČETKA MONTIRANJA OBAVEZNO PROČITAJTE UPUTSTVO ZA MONTAŽU / **MK** ПРЕД ПОЧЕТОК НА МОНТИРАЊЕ ЗАДОЛЖИТЕЛНО ДА СЕ ПРОЧИТА УПАТСТВОТО ЗА МОНТИРАЊЕ / **AL** PËR Fillimit të montimit lexoni patjetër udhëzimin për montim / **PL** PRZED ROZPOCZĘCIEM MONTAŻU PROSZĘ ZAPOZNAĆ SIĘ Z INSTRUKCJĄ / **PT** ANTES DE INICIAR A MONTAGEM, CERTIFIQUE-SE DE LER AS INSTRUÇÕES DE MONTAGEM

Var "A"

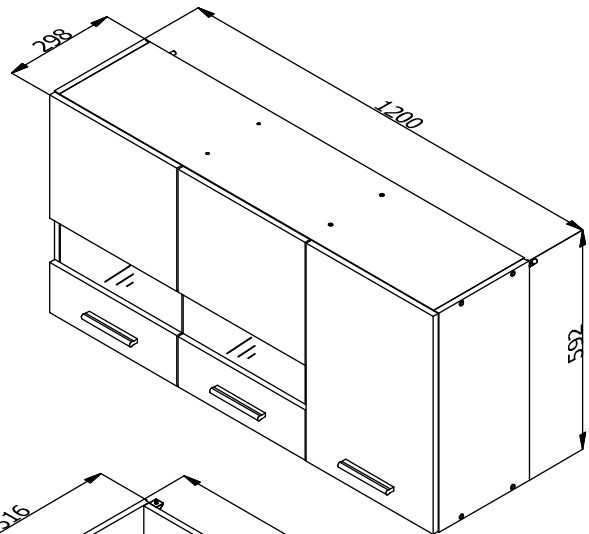
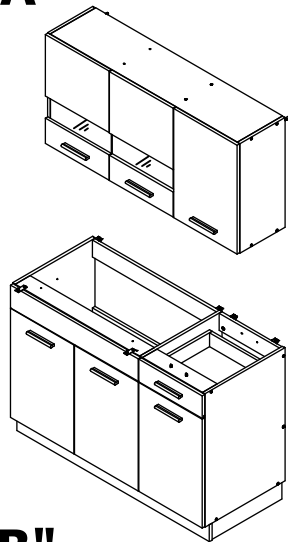

Var "B"

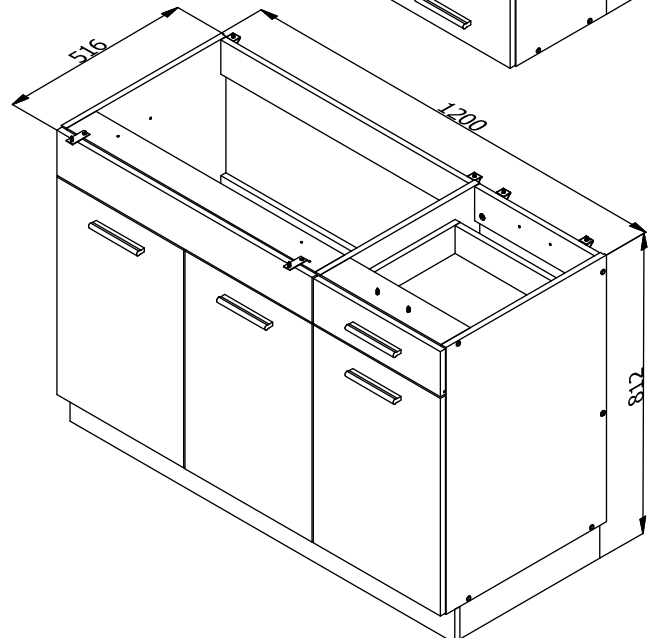
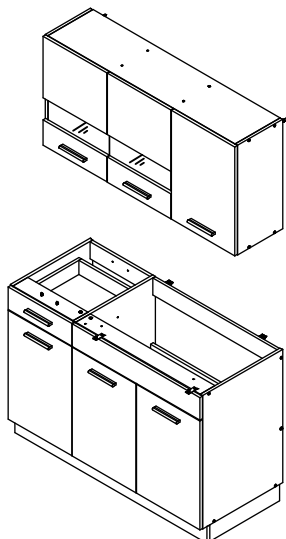

28794	1200 mm	92 mm	16 mm	1	31374	560 mm	279 mm	16 mm	1	Package 1/3	
28795	440 mm	92 mm	16 mm	2	31375	592 mm	282 mm	16 mm	2	28794	1
28800	1168 mm	497 mm	16 mm	1	31376	767 mm	242 mm	16 mm	1	28795	2
28803	330 mm	792 mm	3 mm	1	31377	242 mm	383 mm	16 mm	1	28800	1
28804	393 mm	660 mm	3 mm	1	31378	720 mm	500 mm	16 mm	1	28803	1
28823	375 mm	400 mm	16 mm	1	31379	720 mm	500 mm	16 mm	1	28804	1
29116	396 mm	122 mm	16 mm	1	31380	704 mm	497 mm	16 mm	1	28823	1
29117	312 mm	76 mm	16 mm	1	31420	396 mm	332 mm	16 mm	1	29116	1
29118	588 mm	396 mm	16 mm	4	31421	396 mm	332 mm	16 mm	1	29117	1
29122	405 mm	342 mm	3 mm	1	31422	396 mm	136 mm	16 mm	1	29118	2
31217	400 mm	76 mm	16 mm	2	31423	396 mm	136 mm	16 mm	1	29122	1
31368	376 mm	92 mm	16 mm	2	31424	578 mm	401 mm	3 mm	1	31217	2
31370	776 mm	92 mm	16 mm	1	31427	784 mm	578 mm	3 mm	1	31368	2
31372	1168 mm	282 mm	16 mm	2	31428	796 mm	122 mm	16 mm	1	31370	1

31430	776 mm	92 mm	16 mm	2	31378	720 mm	500 mm	16 mm	1	31378	1
31011501	380 mm	160 mm	4 mm	2	31379	720 mm	500 mm	16 mm	1	31379	1

31380	704 mm	497 mm	16 mm	1	31380	704 mm	497 mm	16 mm	1	31380	1
31424	578 mm	401 mm	3 mm	1	31424	578 mm	401 mm	3 mm	1	31424	1
31428	796 mm	122 mm	16 mm	1	31428	796 mm	122 mm	16 mm	1	31428	1
31430	776 mm	92 mm	16 mm	2	31430	776 mm	92 mm	16 mm	2	31430	2





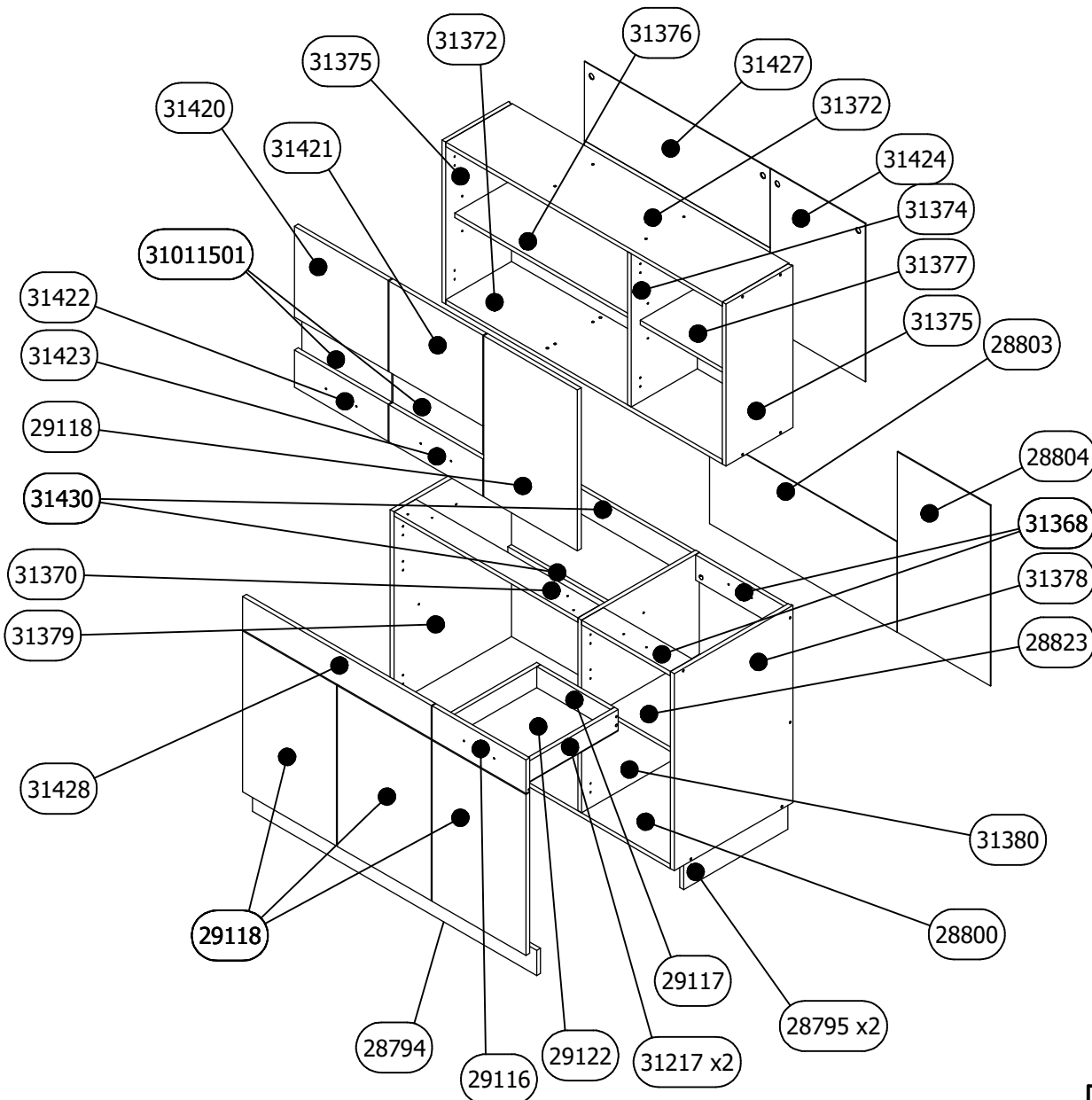



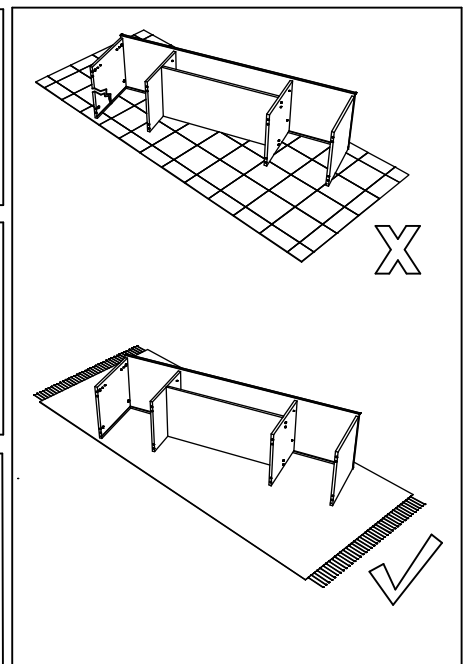
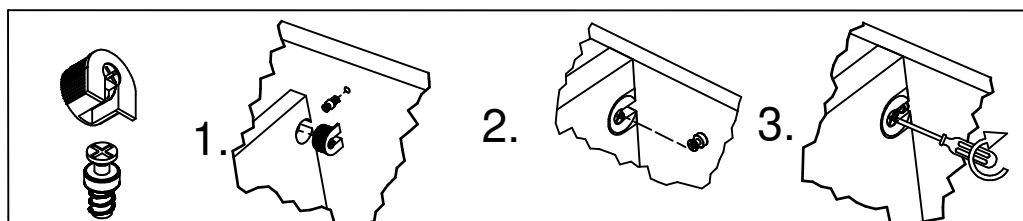
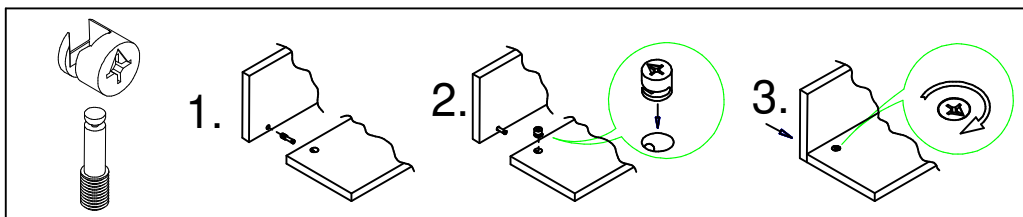
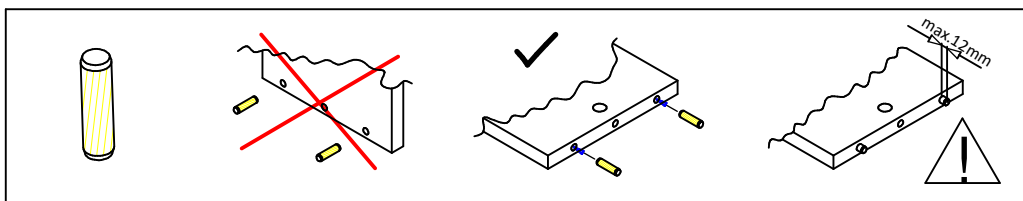













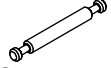



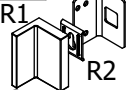









Package 2/3	
31372	2
31374	1
31375	2
31376	1
31377	1
31427	1

Package 3/3	
29118	2
31421	1
31422	1
31420	1
31423	1
31011501	2



<p>RS ME</p> <p>1. Montažu obavljati na čistoj i mekoj podlozi (karton, tkanina...)</p> <p>2. Da bi izbegli oštećenja elemenata pridržavati se datih instrukcija.</p> <p>3. Prilikom prijave reklamacije koristiti date oznake elemenata.</p>	<p>FR CH</p> <p>1. Effectuer l'assemblage sur une surface propre et douce (carton, tissu...)</p> <p>2. Afin d'éviter l'endommagement des éléments, respectez les instructions données.</p> <p>3. Lors de l'application de réclamation, utiliser les désignations données des éléments.</p>
<p>DE AT CH</p> <p>1. Die Montage soll auf sauberer, weicher Fläche durchgeführt werden (Karton, Stoff)</p> <p>2. Um die Beschädigung der Elemente zu vermeiden, befolgen Sie bitte die angegebenen Instruktionen</p> <p>3. Bei Reklamationsmeldungen benutzen Sie bitte die angegebenen Kennzeichen der Elemente</p>	<p>UK</p> <p>1. Assembly of the product should be done on a clean and soft surface (cardboard, fabric)</p> <p>2. To prevent damage of the product, it is necessary to adhere to the assembly instructions</p> <p>3. While reporting defective products, please quote codes in manual</p>
<p>ES</p> <p>1. Realizar el montaje sobre una superficie limpia y suave (cartón, paño)</p> <p>2. Para evitar daños del producto, atenerse a las instrucciones de montaje</p> <p>3. Para reportar productos defectuosos, refiérase por favor a los códigos del manual</p>	<p>IT CH</p> <p>1. Eseguire l'installazione su una base morbida (cartone, tessuto).</p> <p>2. Seguire le istruzioni per evitare di causare danni agli elementi.</p> <p>3. In caso della presentazione di reclamo si utilizzano relative indicazioni degli elementi.</p>
<p>RO</p> <p>1. Montarea se efectueaza pe o suprafata moale și curată (carton, material..)</p> <p>2. Respectați instrucțiunile pentru a evita deteriorarea pieselor</p> <p>3. La transmiterea reclamațiilor a se folosi inscripțiile date ale pieselor</p>	<p>CZ SK</p> <p>1. Montáž provádět na čistém a měkkém podkladu (lepenka, látka)</p> <p>2. Dodržujte příložené instrukce, abyste předešli poškození součástí</p> <p>3. Při reklamaci používejte přiložené označení element</p>
<p>EL</p> <p>1. Η συναρμολόγηση του προϊόντος πρέπει να γίνει σε καθαρή και μαλακή επιφάνεια (χαρτόνι, ύφασμα).</p> <p>2. Για να μην φθαρούν τα στοιχεία, συμμορφωθείτε με τις οδηγίες που παρέχονται.</p> <p>3. Κατά τη δήλωση ελαττωματικού προϊόντος, αναφέρετε τους κώδικες των στοιχείων όπως αναφέρονται στο εγχειρίδιο.</p>	<p>RUS BLR</p> <p>1. Монтаж изделия выполнять на чистой и мягкой поверхности (картон, ткань)</p> <p>2. Для предотвращения порчи изделий необходимо придерживаться правил монтажа</p> <p>3. В случае предъявления претензии использовать данные обозначения элементов.</p>
<p>BG</p> <p>1. Монтажът трябва да бъде извършен върху чиста и мека основа /karton, тъкан/</p> <p>2. За да избегнете оцетяване на елементи, спазвайте дадените инструкции</p> <p>3. При наличие на рекламация, използвайте дадените кодове на елементи</p>	<p>HU</p> <p>1. A szerelés tisztaság és puha felületen (karton, anyag) kell végrehajtani.</p> <p>2. Károsodásnak elkerülése érdekében, tartsa be a megadott utasításokat.</p> <p>3. Reklamáció esetén hivatkozzon a bútor alkatrészein megadott jelekre.</p>
<p>SL</p> <p>1. Montažo opravimo na čisti in mehki podlogi (karton, tkanina)</p> <p>2. Da bi se ozognili poškodbam elementov, upoštevajte navodila.</p> <p>3. Pri reklamaciji uporabimo oznake elementov</p>	<p>BIH HR</p> <p>1. Montažu obavljati na čistoj i mekoj podlozi (karton, tkanina)</p> <p>2. Da bi izbegli oštećenja elemenata pridržavati se datih instrukcija</p> <p>3. Prilikom prijave reklamacije koristiti date oznake elemenata</p>
<p>MK</p> <p>1. Монтажа да се врши на чиста и мека подлога (karton, ткаенина)</p> <p>2. За да се избегне оштетување на елементите придржувајте се на дадените инструкции</p> <p>3. За пријава на рекламации користете ги дадените ознаки на елементите</p>	<p>AL</p> <p>1. Montimi të bëhet në sipërfaqe të pastër dhe të butë (karton, pëlhurë)</p> <p>2. Që t'u shmangeni dëmtimit të elementeve, përmbahuni instrukcioneve të dhëna</p> <p>3. Me rastin e reklamimit përdorni shenjat e dhëna të elementit</p>
<p>PL</p> <p>1. Montować należy na czystej i miękkiej powierzchni (karton, tkanina)</p> <p>2. Aby uniknąć uszkodzenia elementów należy postępować ściśle według instrukcji.</p> <p>3. Przy zgłaszaniu reklamacji należy posługiwać się załączonymi oznaczeniami elementów.</p>	<p>HR</p> <p>1. Pažljivo pročitajte upute za montažu</p> <p>2. Pripremite sve dijelove namještaja</p> <p>3. Prikupite i provjerite okove za montažu</p> <p>4. Pripremite potreban alat</p> <p>5. Pripremite prostor za montažu</p> <p>6. Počnite montirati</p> <p>7. Sačuvajte ove ove upute</p> <p>8. Proizvod je namjenjen isključivo za kućnu uporabu</p>
<p>PT</p> <p>1. A montagem deve ser feita em uma superfície limpa e macia (papelão, tecido...)</p> <p>2. Para evitar danos nos elementos, siga as instruções fornecidas.</p> <p>3. Durante a apresentação de reclamação usar os rótulos dos elementos fornecidos.</p>	



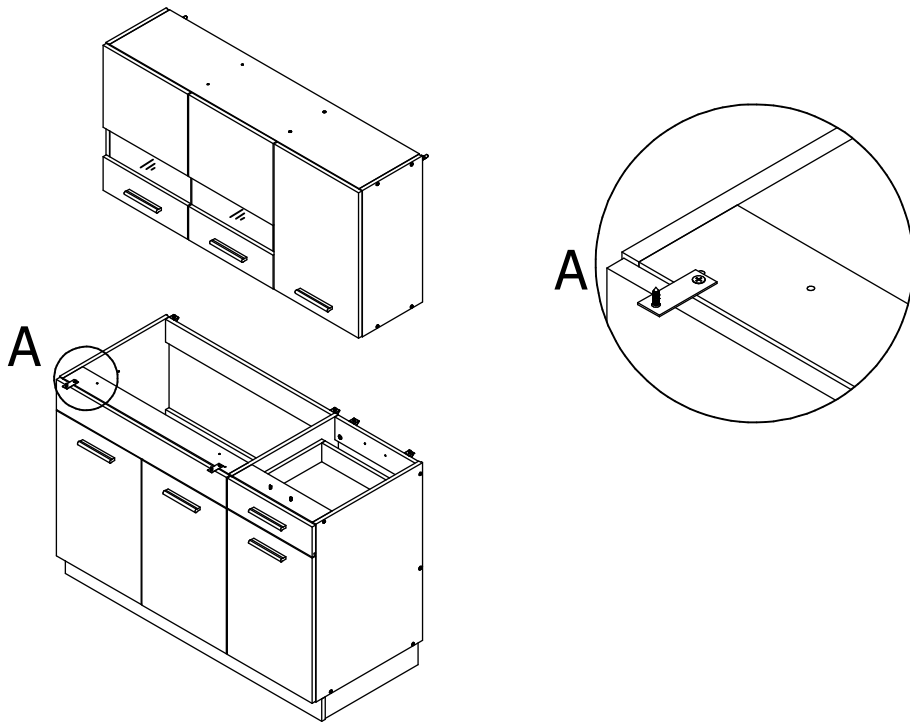

A Ø8x30 x28 	B Ø7x50 x25 	C Ø7 x10 	D Ø8 x6 	E x12 	F x1 	G Ø6.3x10 x8 	H x12 	I x4 	J 6x16 x2 
K x7 	L Ø8x50 x2 	M x2 	N 4x16 x50 	O x7 	P 4x30 x16 	Q x10 	R R3 x2 	S 6x60 x2 	T x2 
U x3 	V 3x25 x6 	W 1.6 x 25 x50 	X x5 	Y x4 	Z x19 	Aa x4 	Ab 3.5x16 x15 	Ac x4 	Ad 4x30 x2 
Ae x6 	Af x2 	Ag x2 	Ah x8 	Ai x2 	Aj x2 	Ak 4x16 x8 	Al	Am	An

Var "1"



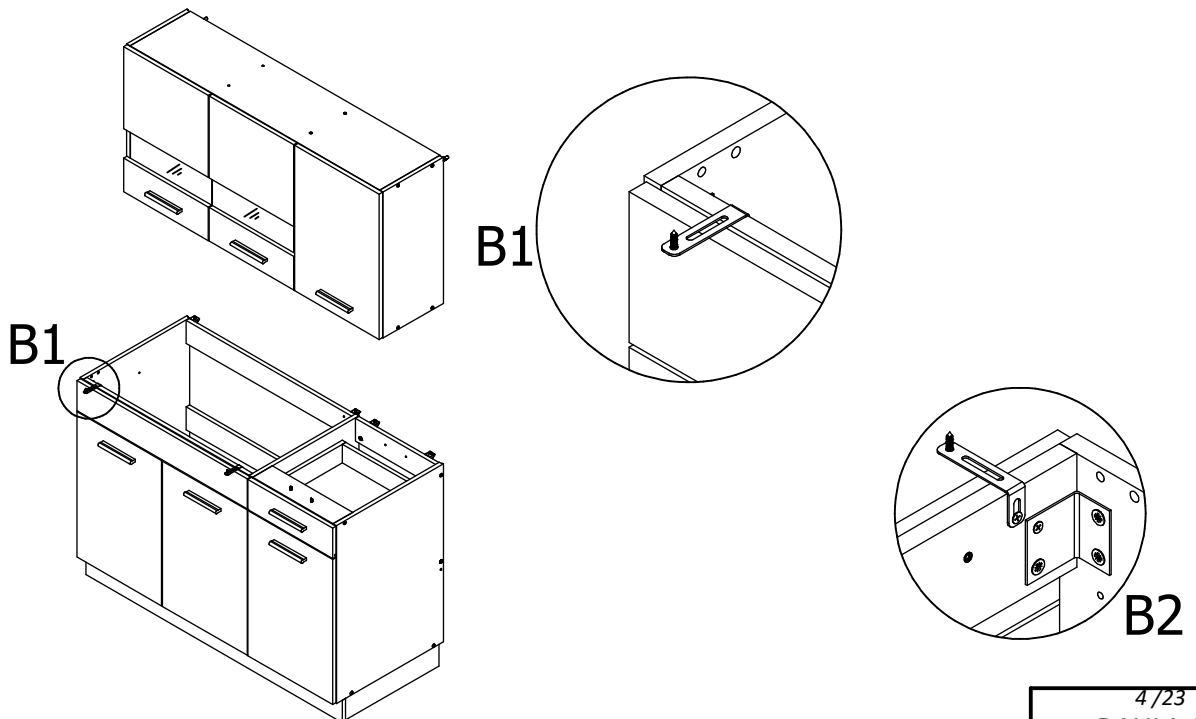

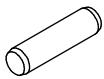
Var "2"

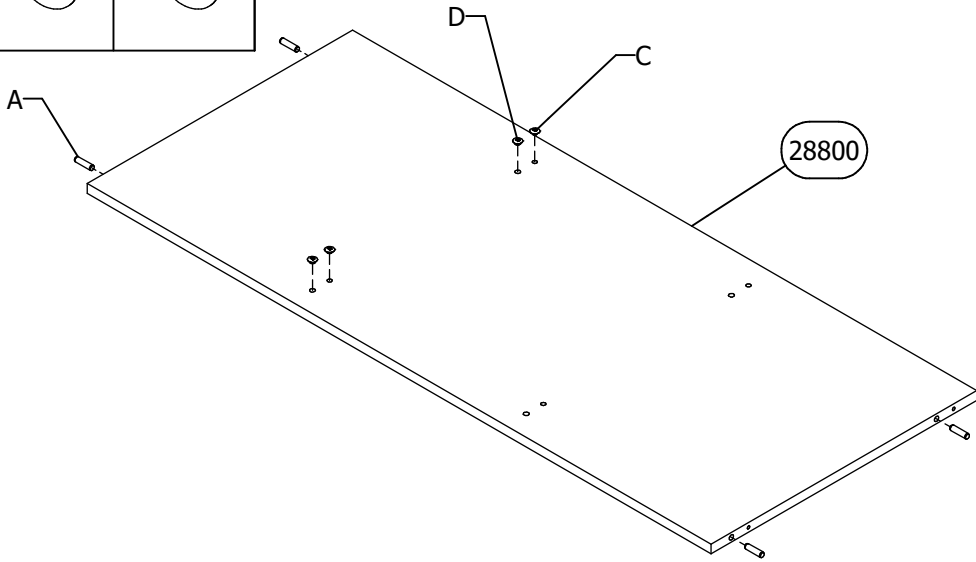

1	A x 4  Ø8x30	C x 2 	D x 2 
----------	--	---	---

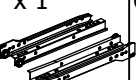

2	E x 2 	F x 1 F2 	G x 2 Ø6.3x10 	H x 2 
----------	--	--	---	--

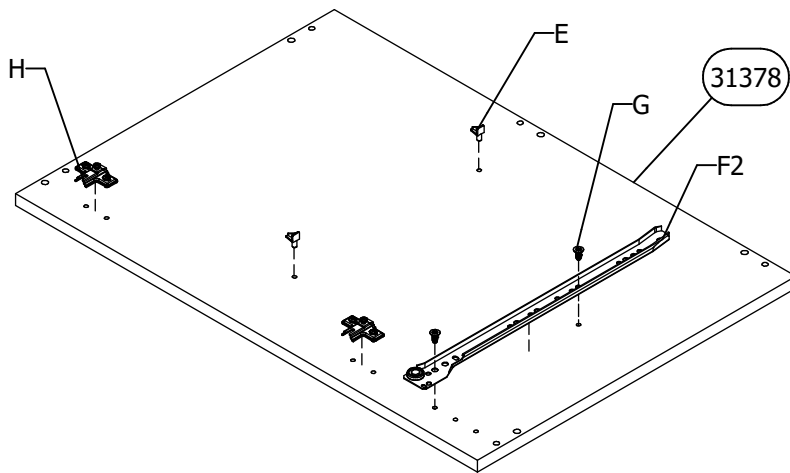

3	H x 2 
----------	--

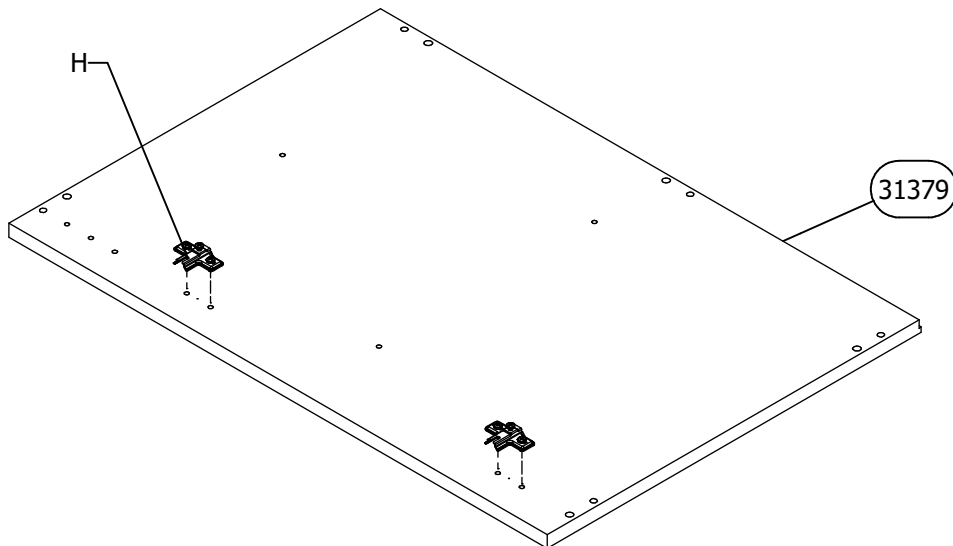

4	A x 2 Ø8x30	E x 2	F x 1 F1	I x 4	J x 2 6x16
----------	----------------	-------	-------------	-------	---------------

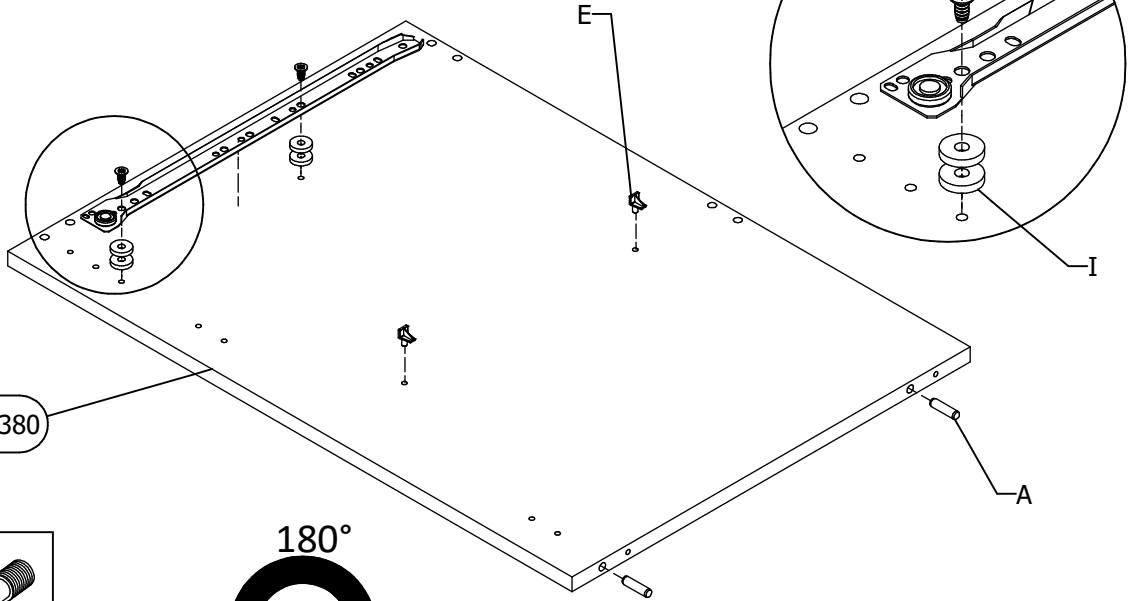

5	H x 2	Aa x 1
----------	-------	--------

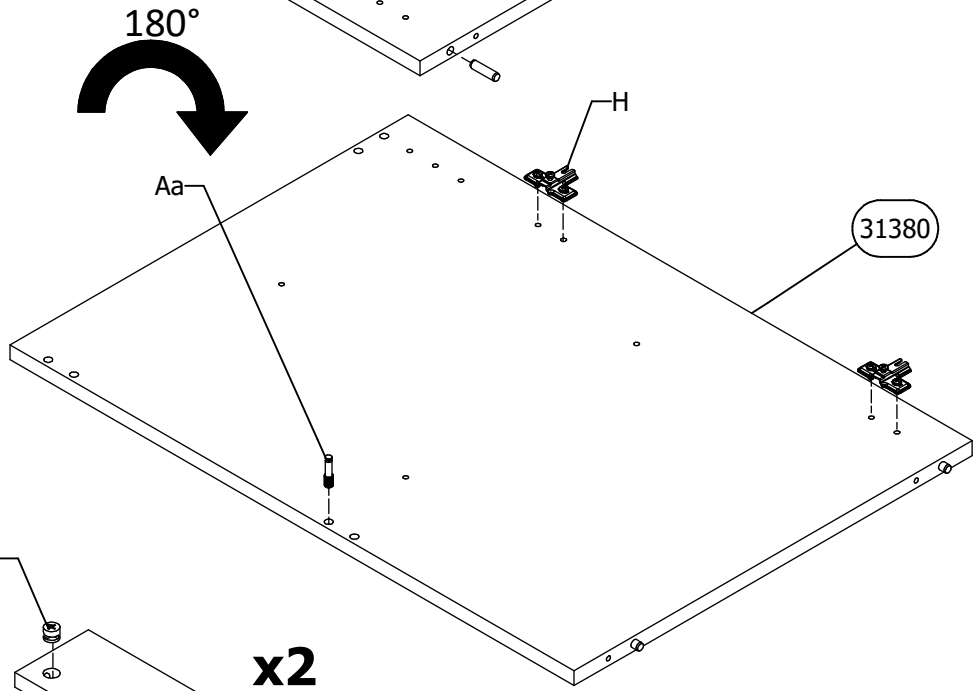

6	A x 2 Ø8x30	K x 2
----------	----------------	-------

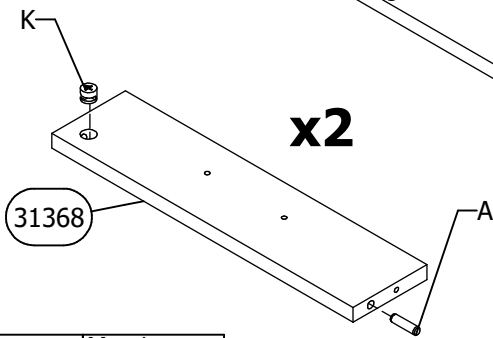

7 V1	A x 1 Ø8x30	L x 1 Ø8x50	K x 1	M x 1
----------------	----------------	----------------	-------	-------

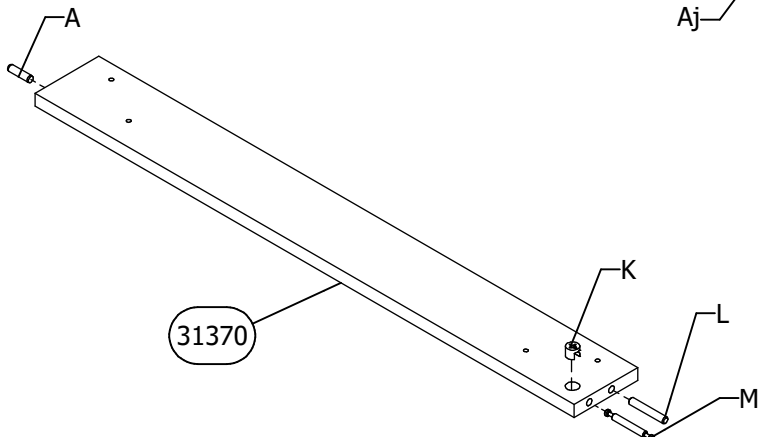

7 V2	G x 2 Ø6.3x10	Aj x 2
----------------	------------------	--------

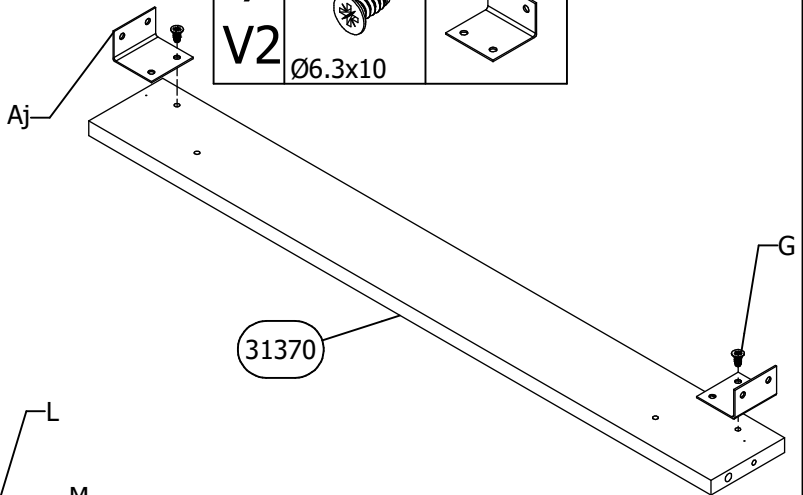

8

A x 3

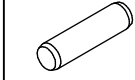

Ø8x30

K x 2



L x 1

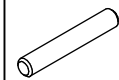

Ø8x50

M x 1

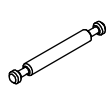

A

31430

K

31430

M

L

9

Ae x 2



Y x 2



N x 4



4x16

Ae

N

Y

N

28795

28795

10

B x 2



Ø7x50

28800

B

31380

11
V1

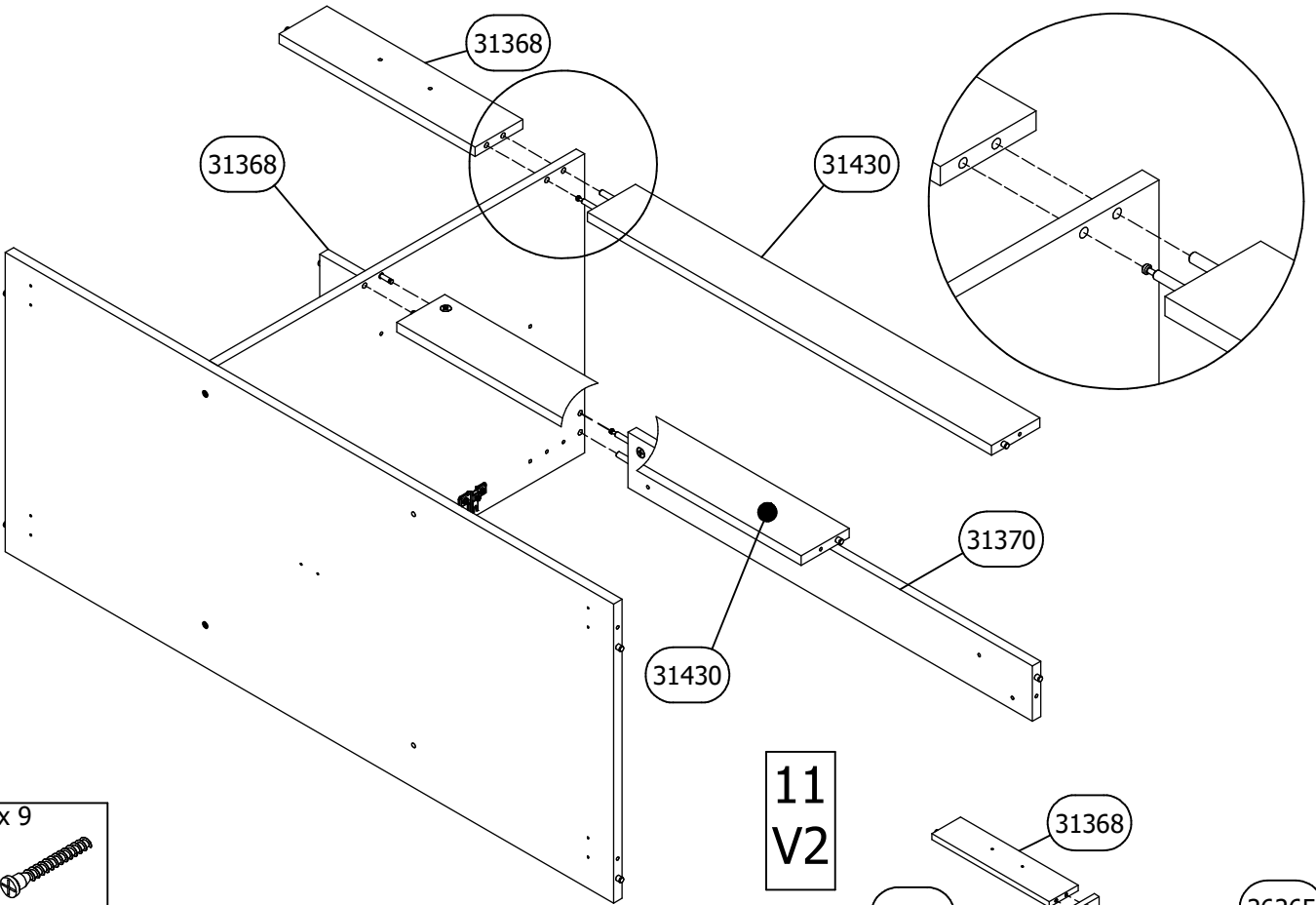



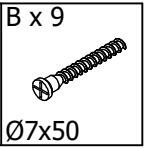

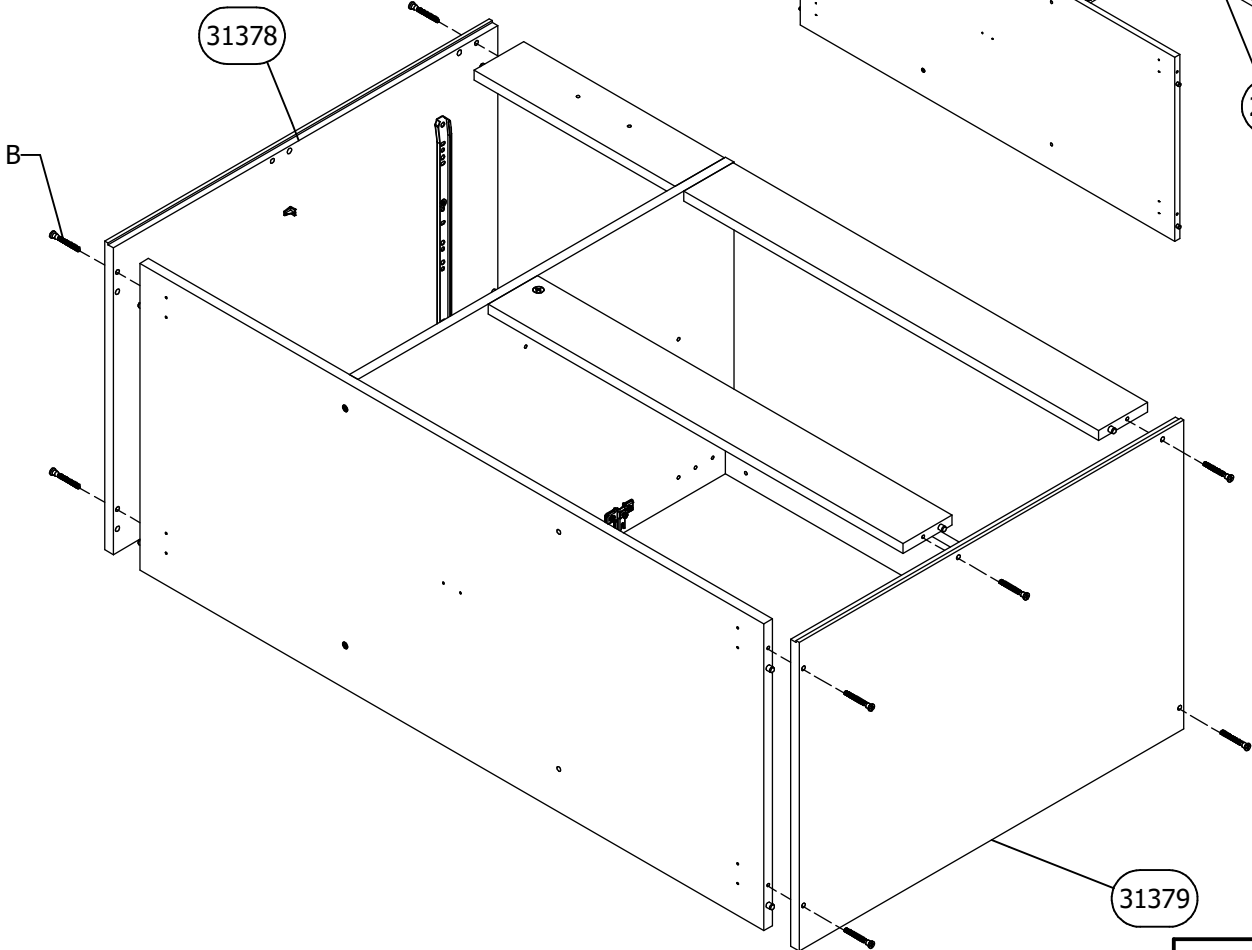
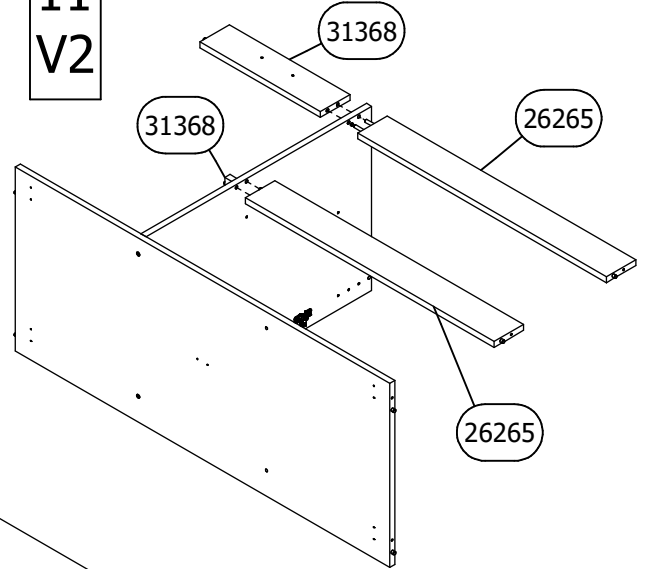

12







11
V2

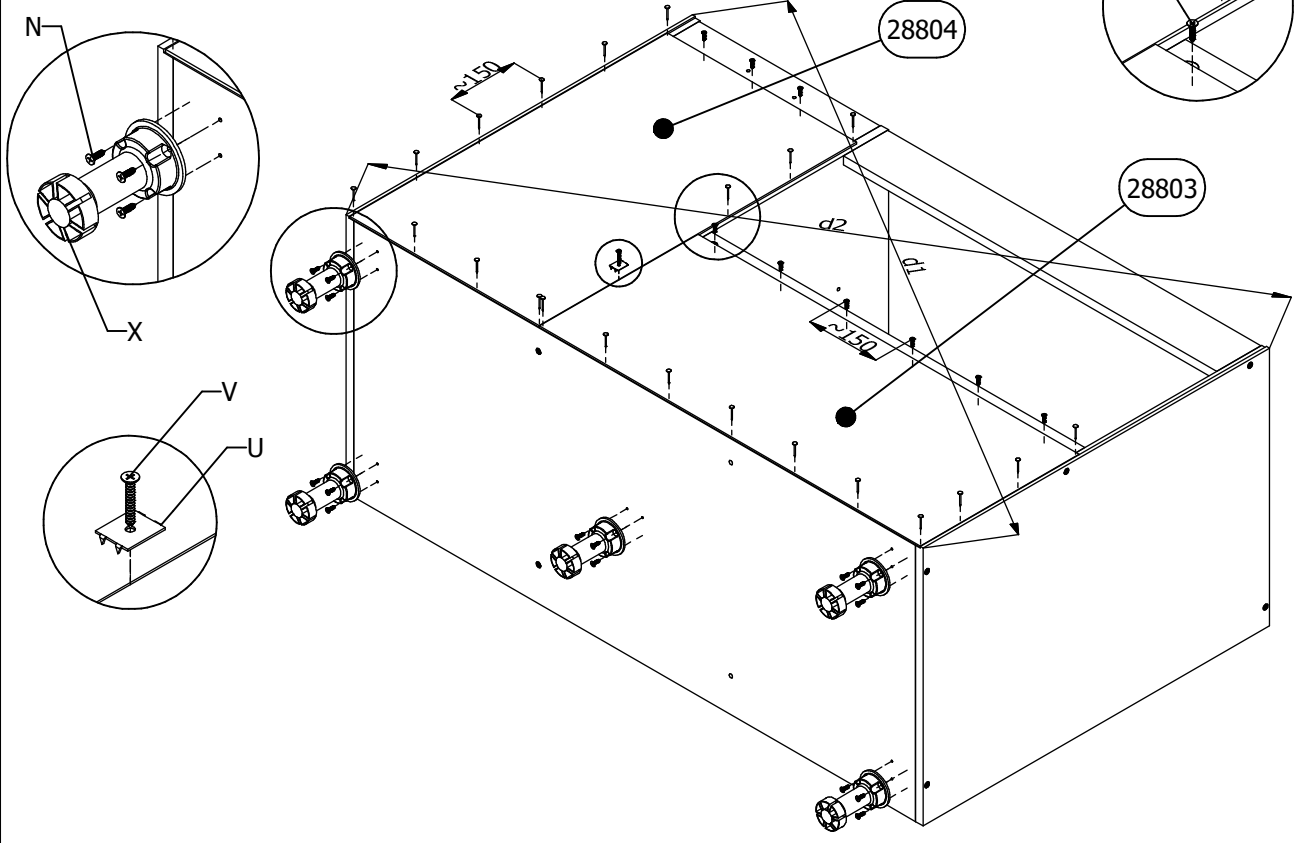
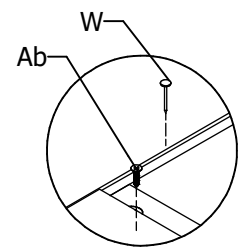

- | | | | | | | |
|-----------|---|--|--|--|---|---|
| 13 | X x 5
 | N x 20

4x16 | W x 22

1.6 x 25 | Ab x 9

3.5x16 | U x 1
 | V x 1

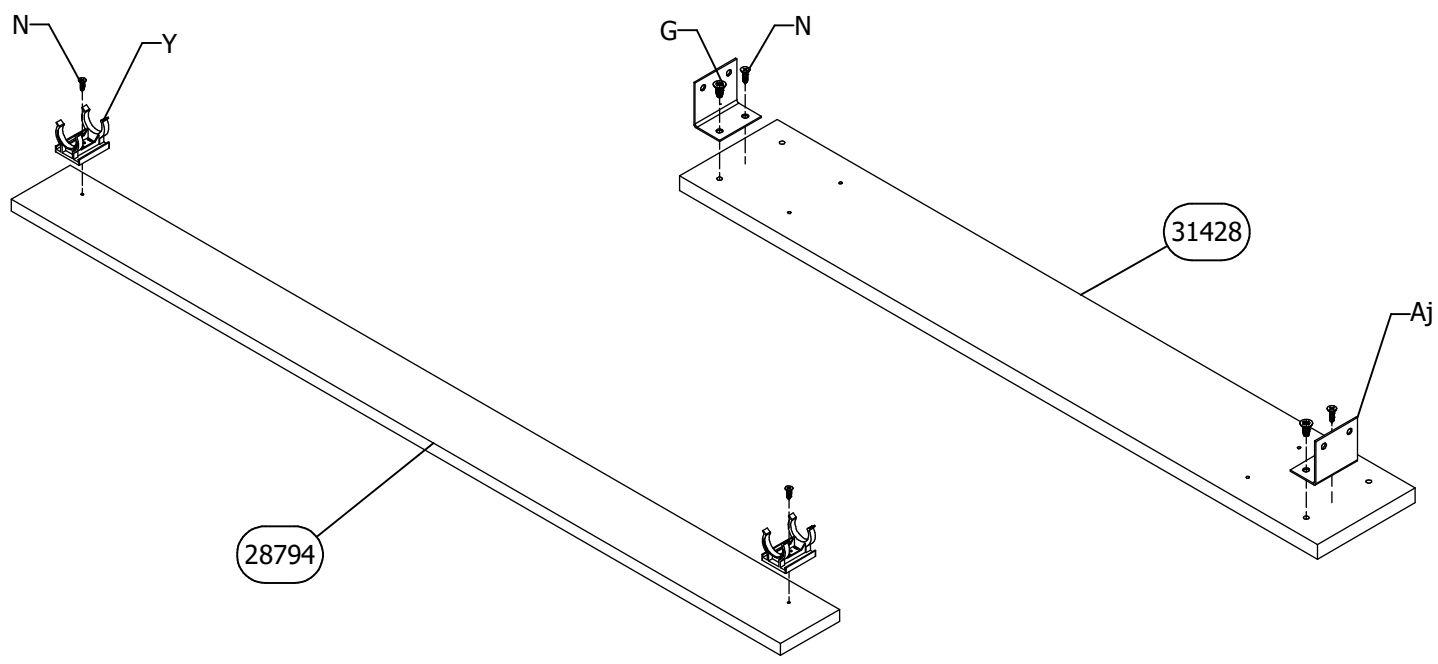
3x25 |
|-----------|---|--|--|--|---|---|





- | | | |
|-----------|--|--|
| 14 | Y x 2
 | N x 2

4x16 |
|-----------|--|--|

- | | | | |
|-----------|--|--|---|
| 15 | G x 2
 | N x 2

4x16 | Aj x 2
 |
| V1 | $\varnothing 6.3 \times 10$ | | |



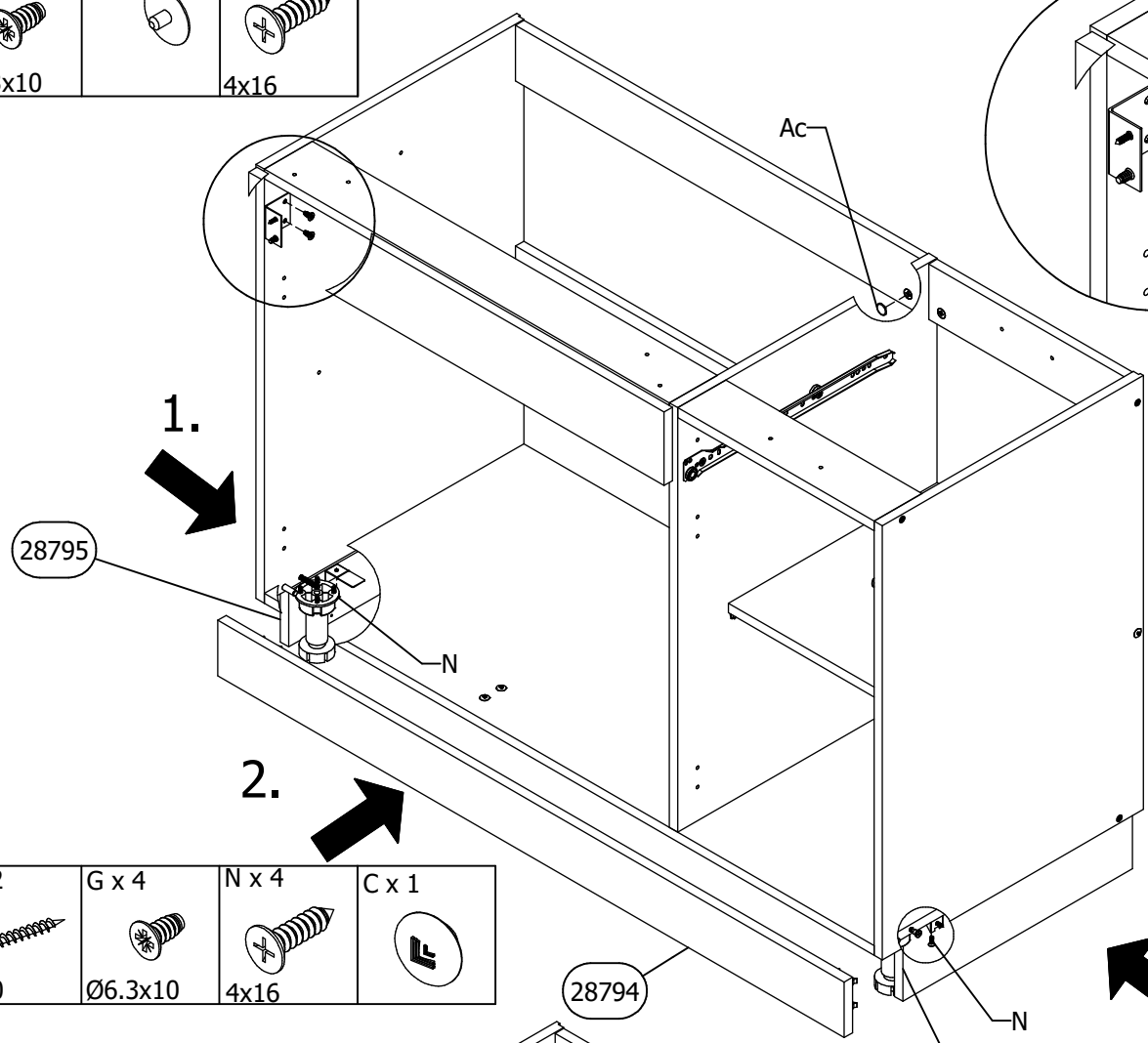
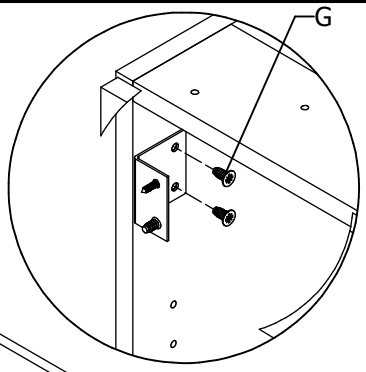



16
V1

G x 4 	Ac x 2 	N x 2 
Ø6.3x10		4x16



16
V2

P x 2 	G x 4 	N x 4 	C x 1 
4x30	Ø6.3x10	4x16	

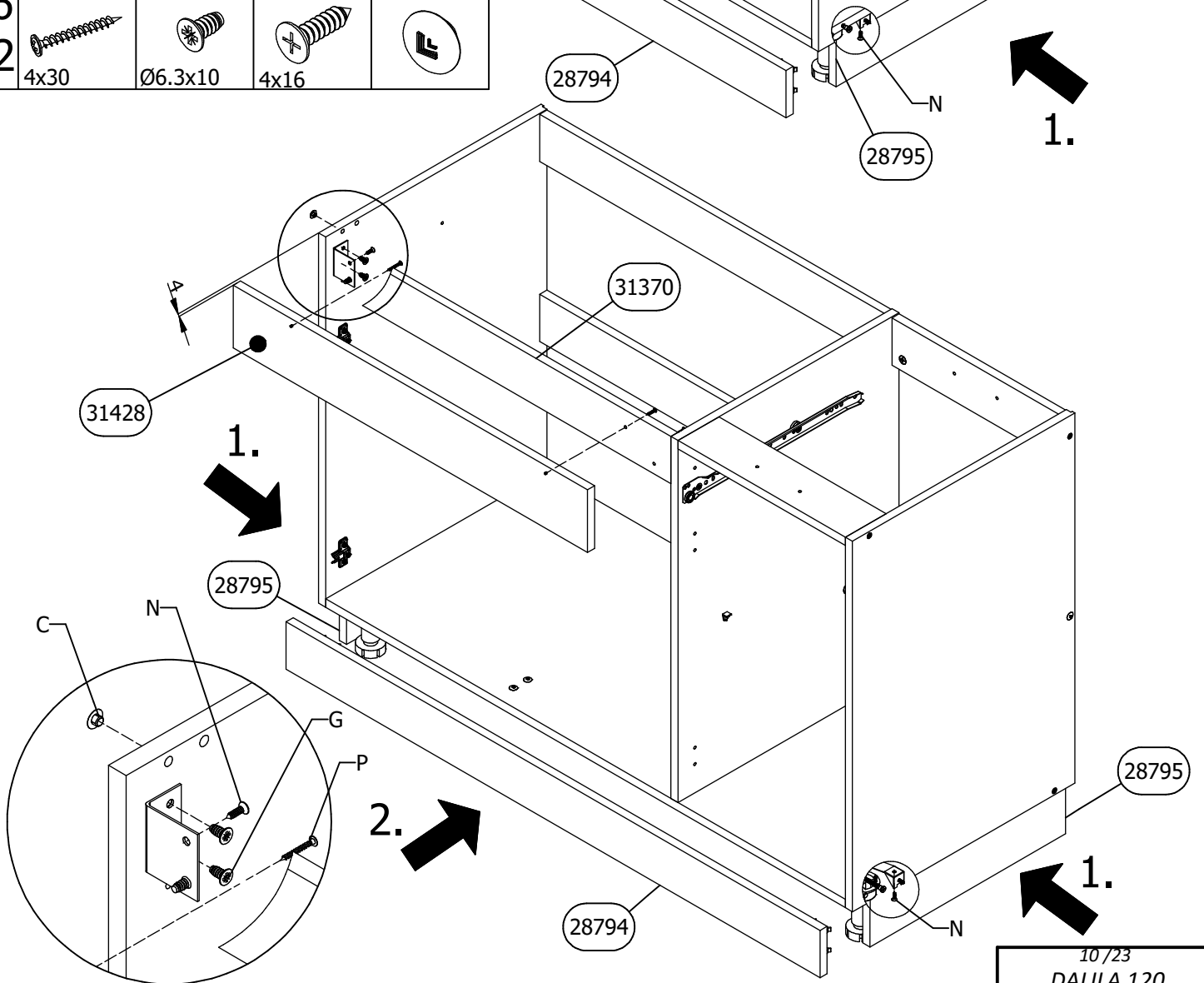

17

K x 2	A x 2
	Ø8x30

18

A x 2
Ø8x30

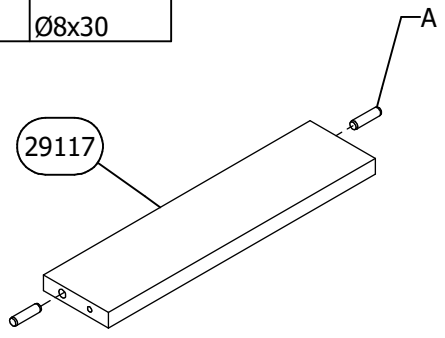
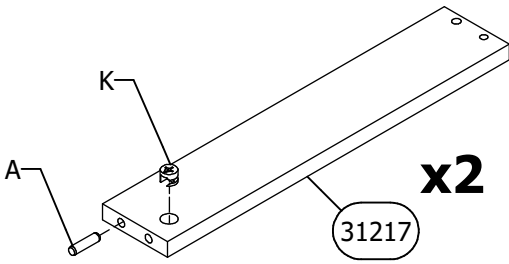

19

Aa x 2

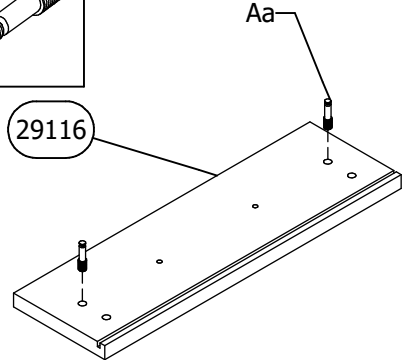

20

B x 2
Ø7x50

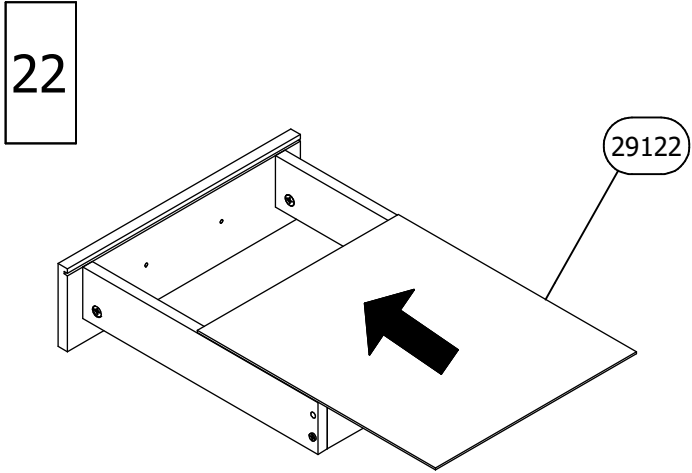
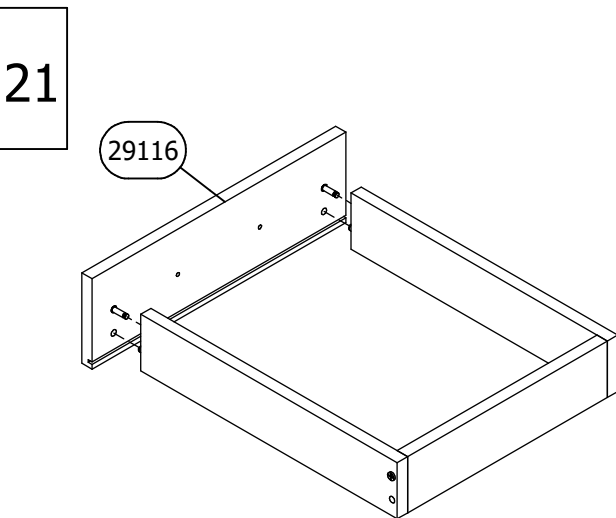
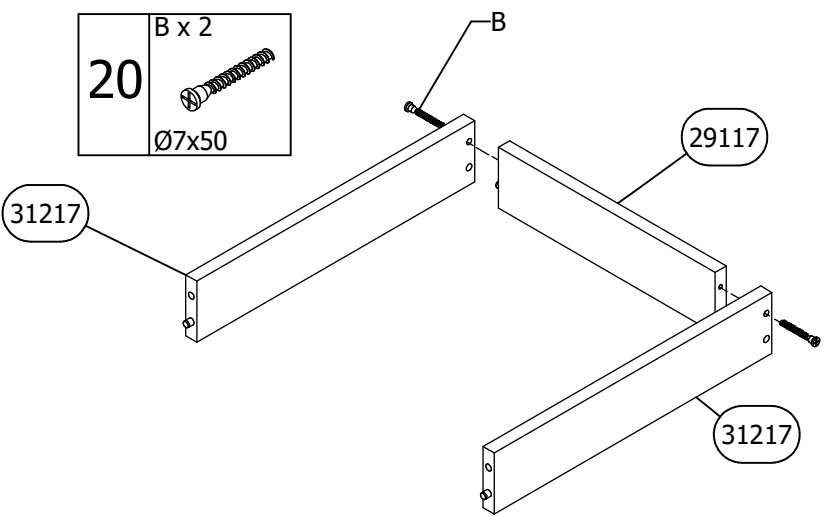

23

F x 2	F3	Ab x 6	V x 3
F4	3.5x16		3x25

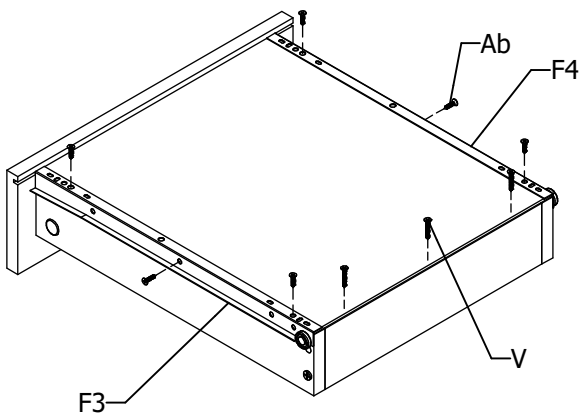



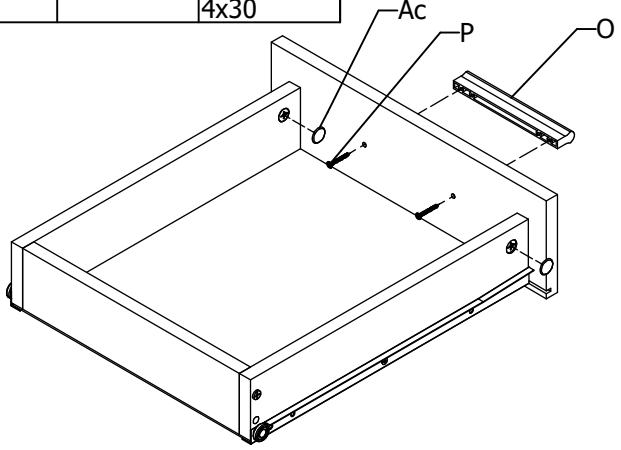

24

Ac x 2	O x 1	P x 2
		4x30

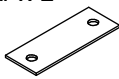

25
V1

C x 1 	Z x 9 	Ae x 4 	N x 6 4x16 	Af x 2 
---	---	--	---	--

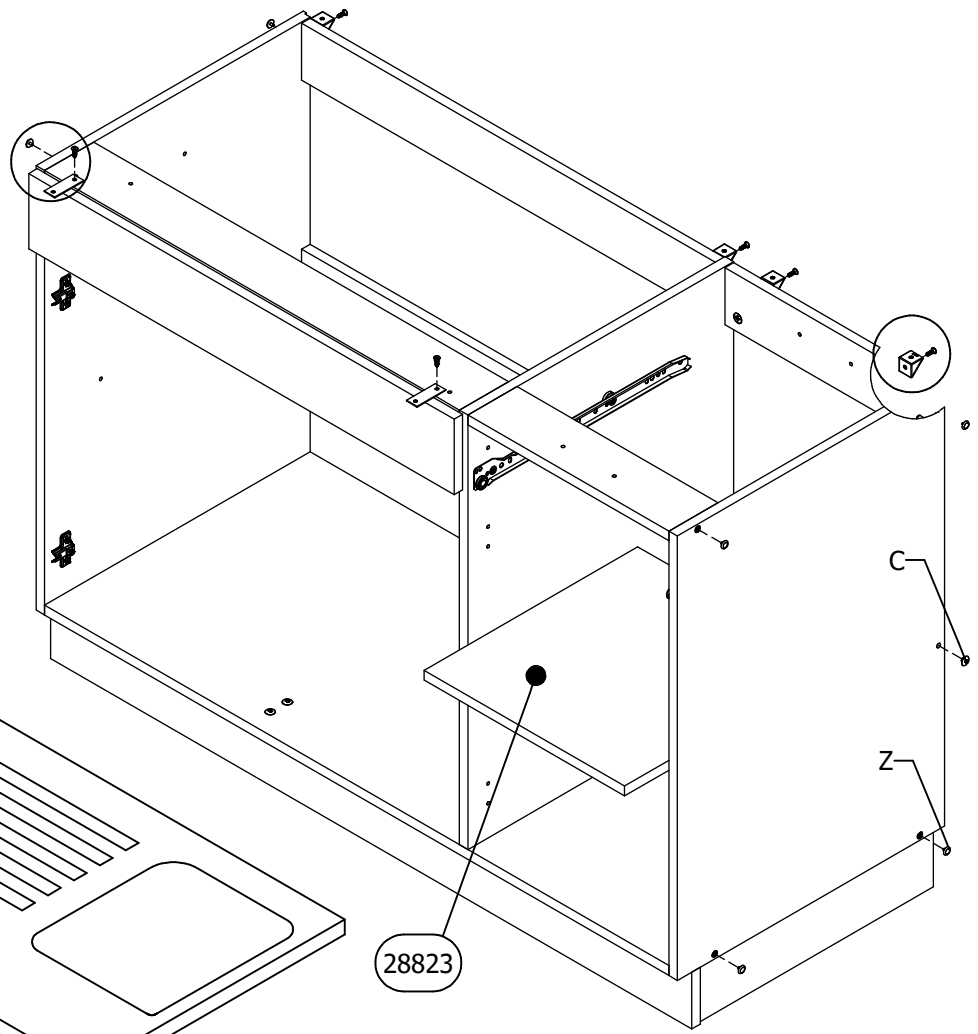
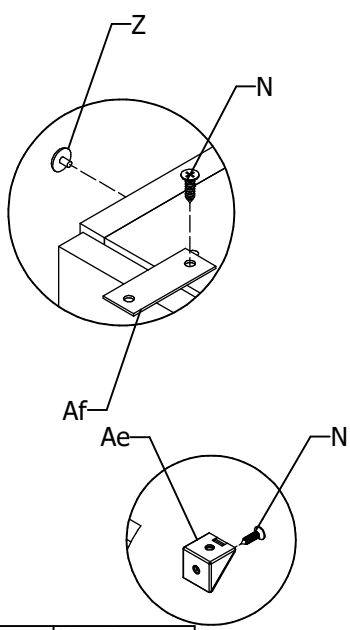

26
V1

N x 4 4x16 
--

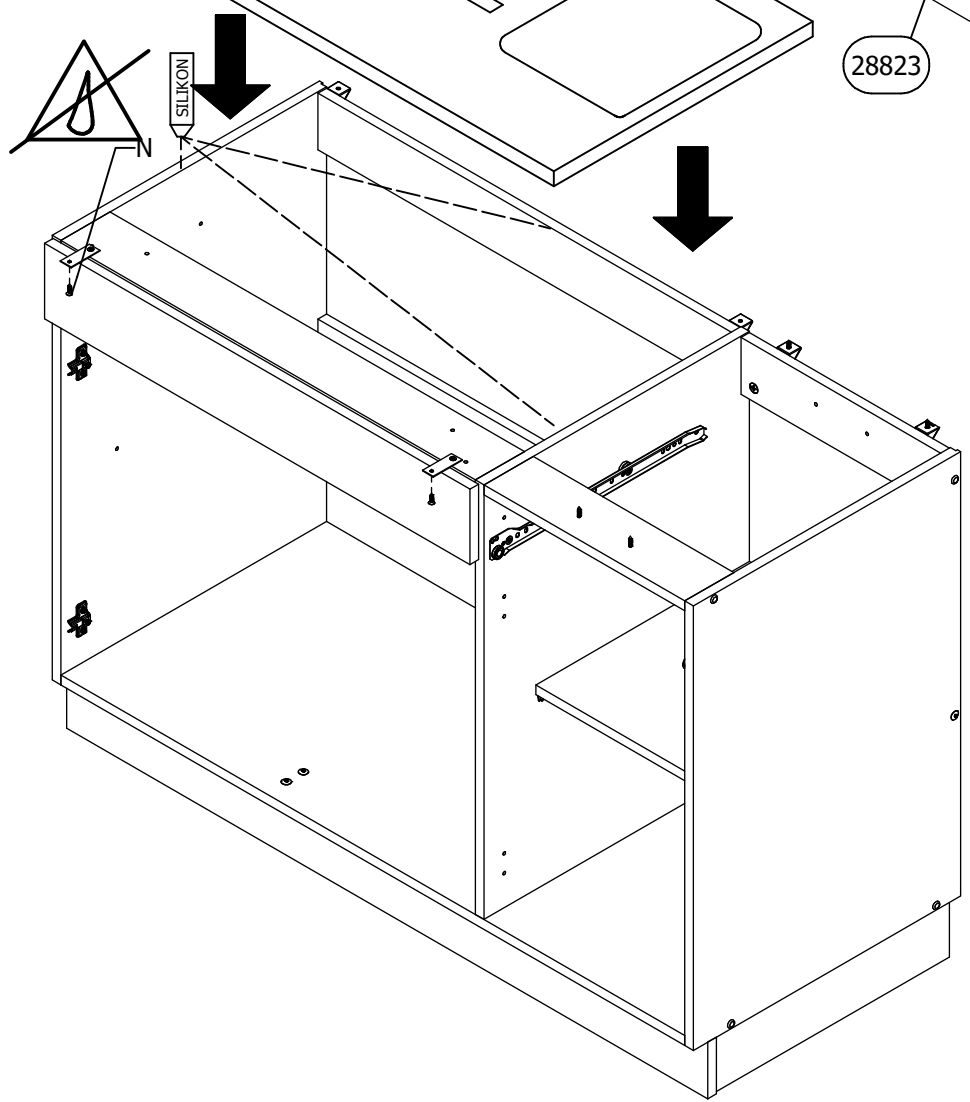

- 25 V2 C x 1
- Aa x 1
- Z x 8
- Ai x 2
- Ae x 4
- N x 10

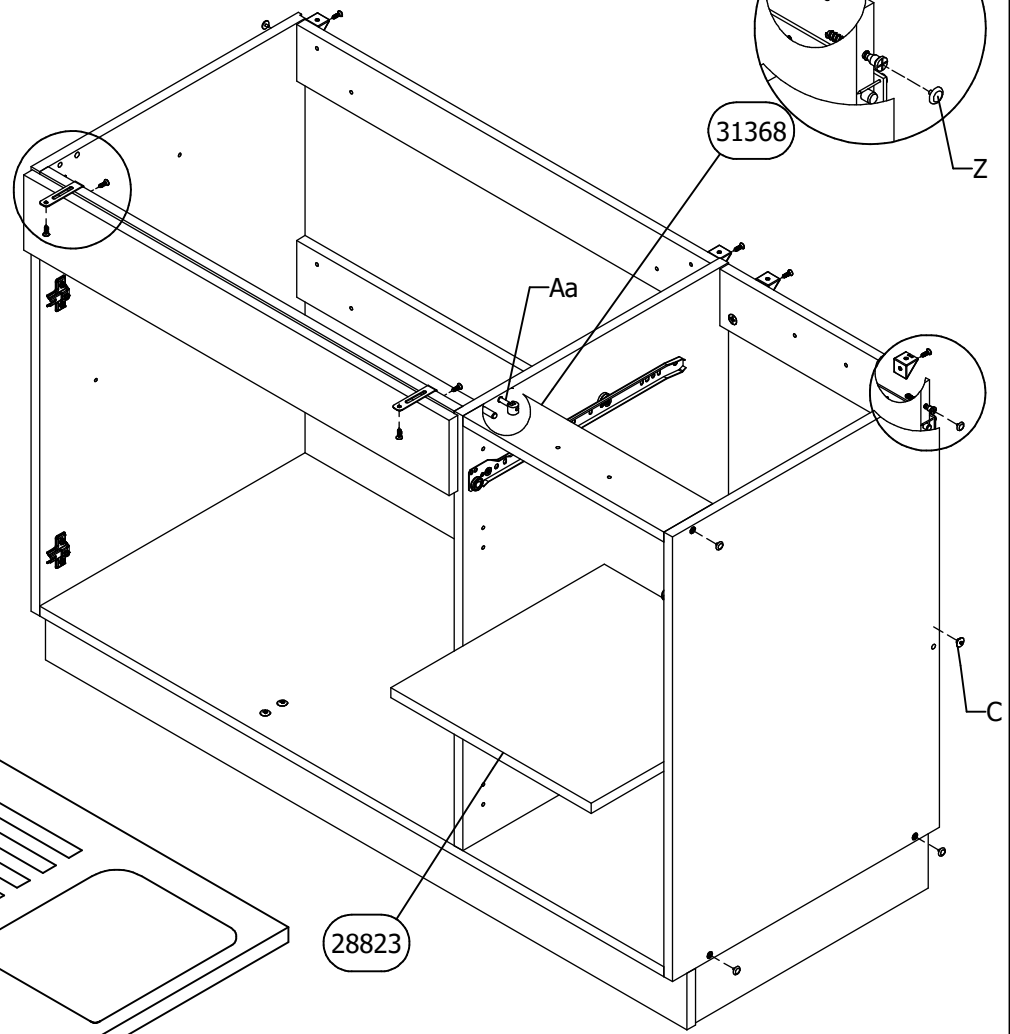
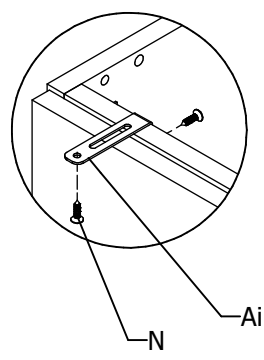
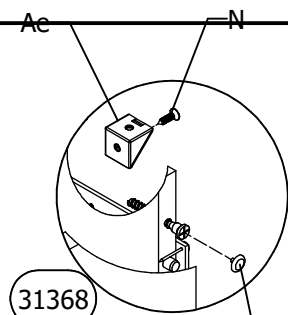

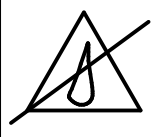

26 V2



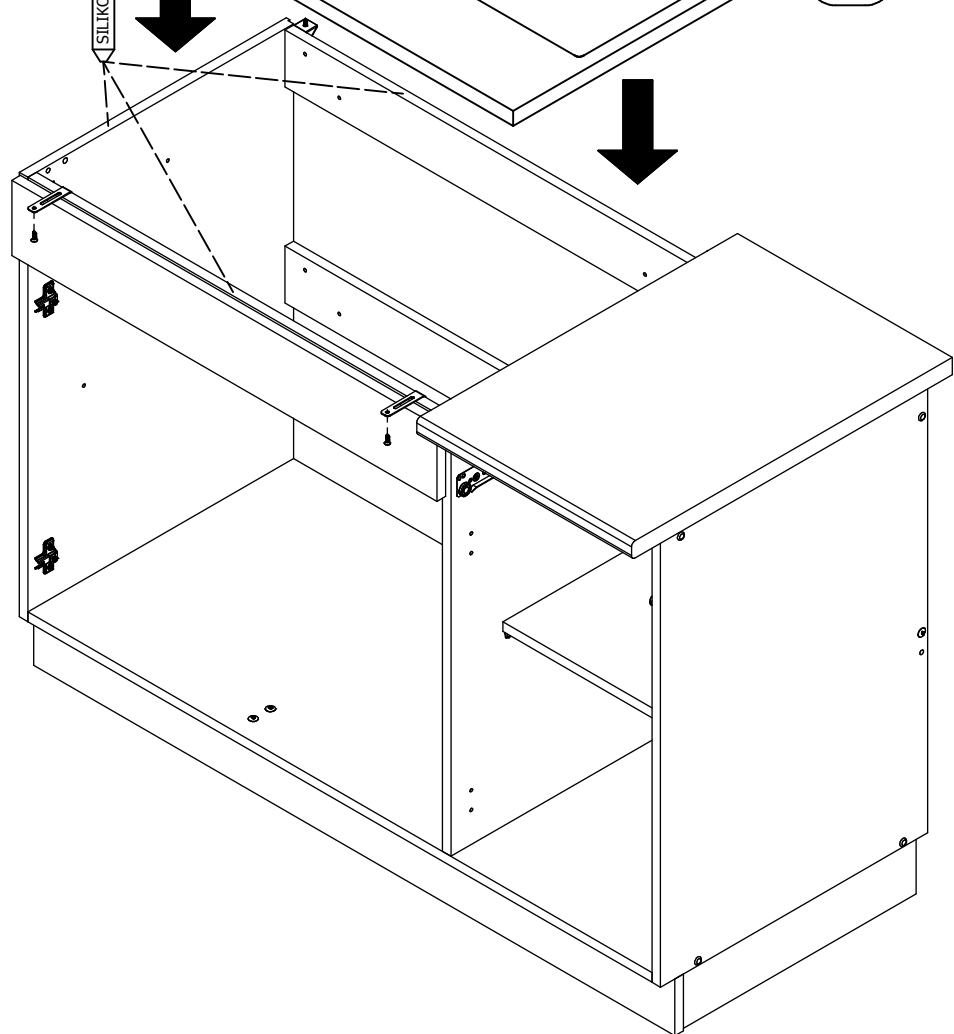
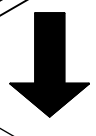
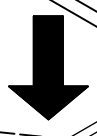

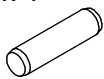
SILIKON



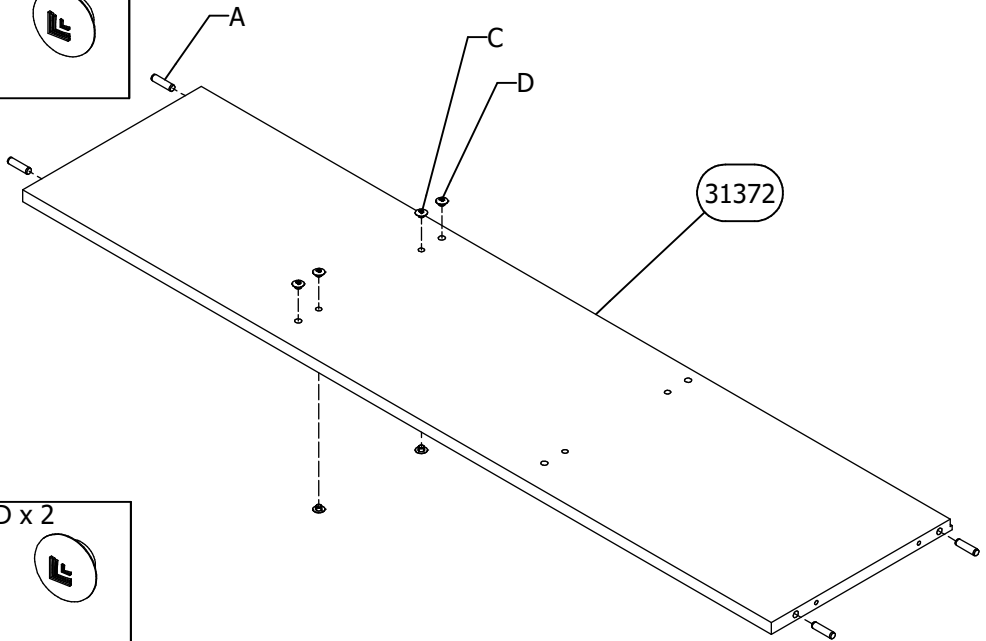

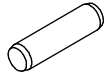

27	A x 4  Ø8x30	C x 4 	D x 2 
-----------	--	---	---

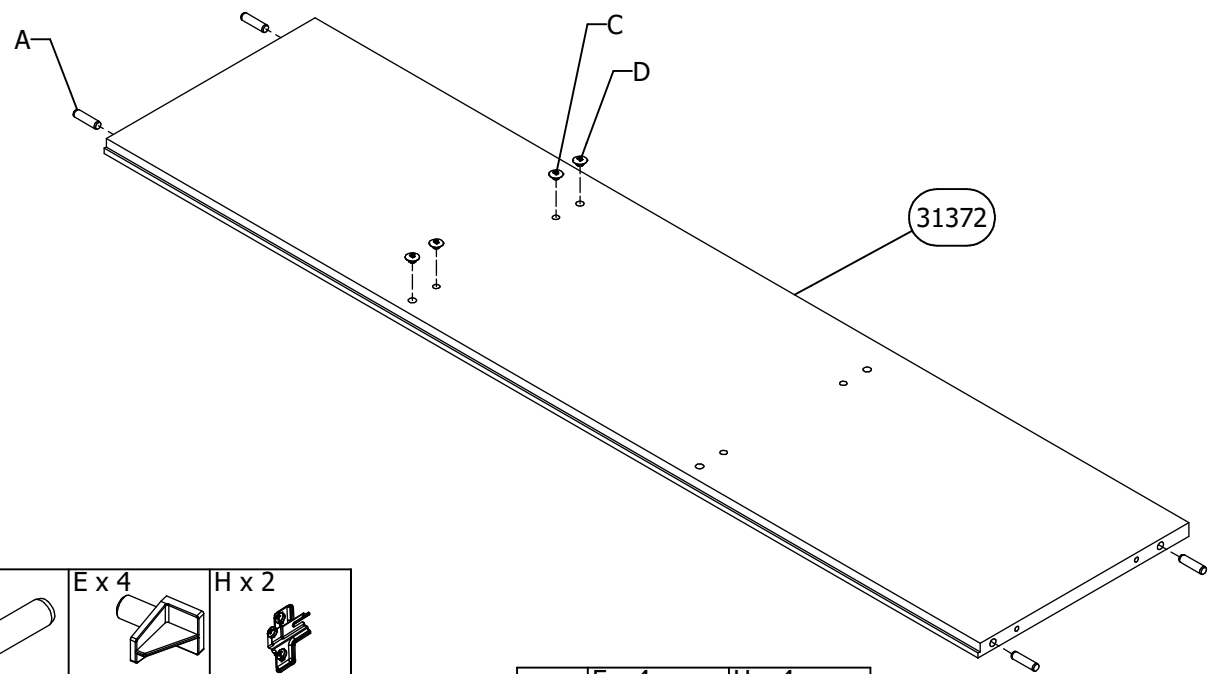

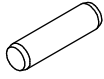

28	A x 4  Ø8x30	C x 2 	D x 2 
-----------	---	--	--



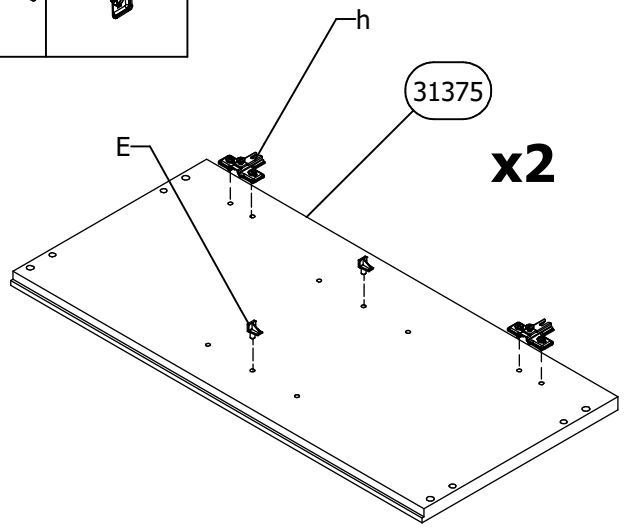
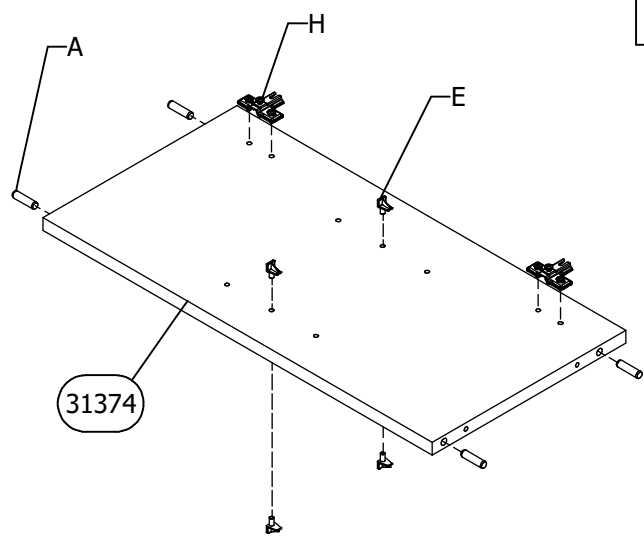

29	A x 4  Ø8x30	E x 4 	H x 2 
-----------	---	--	--

30	E x 4 	H x 4 
-----------	--	---

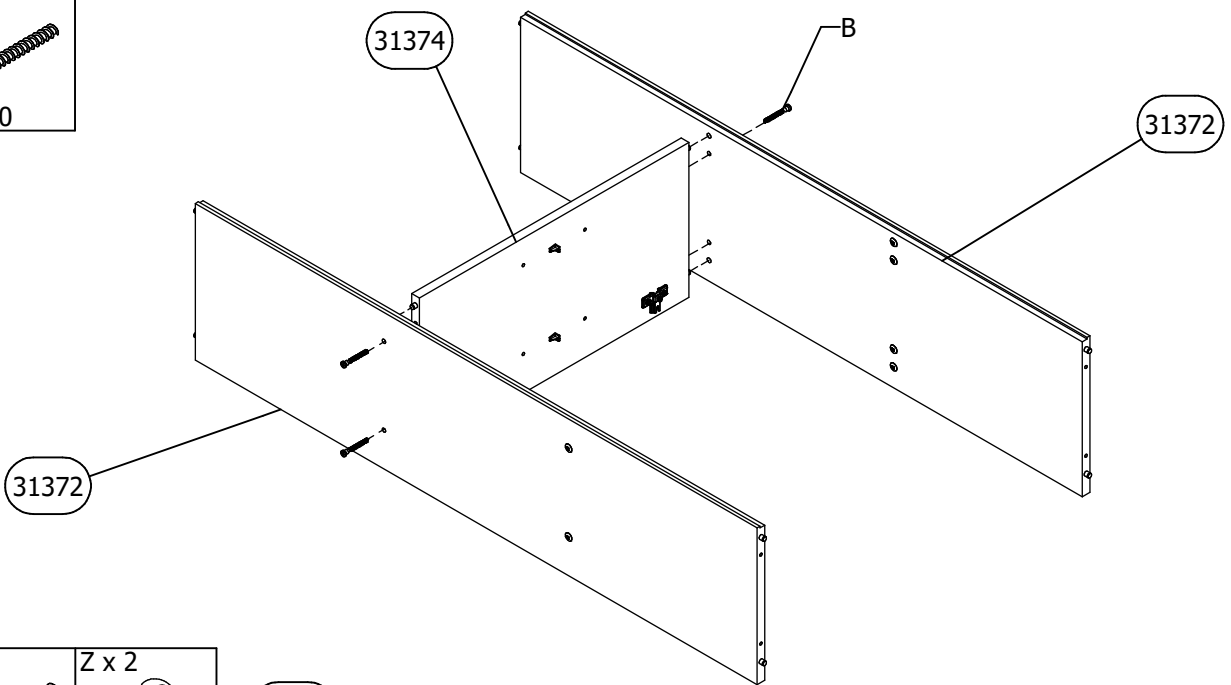

31 B x 4

 Ø7x50

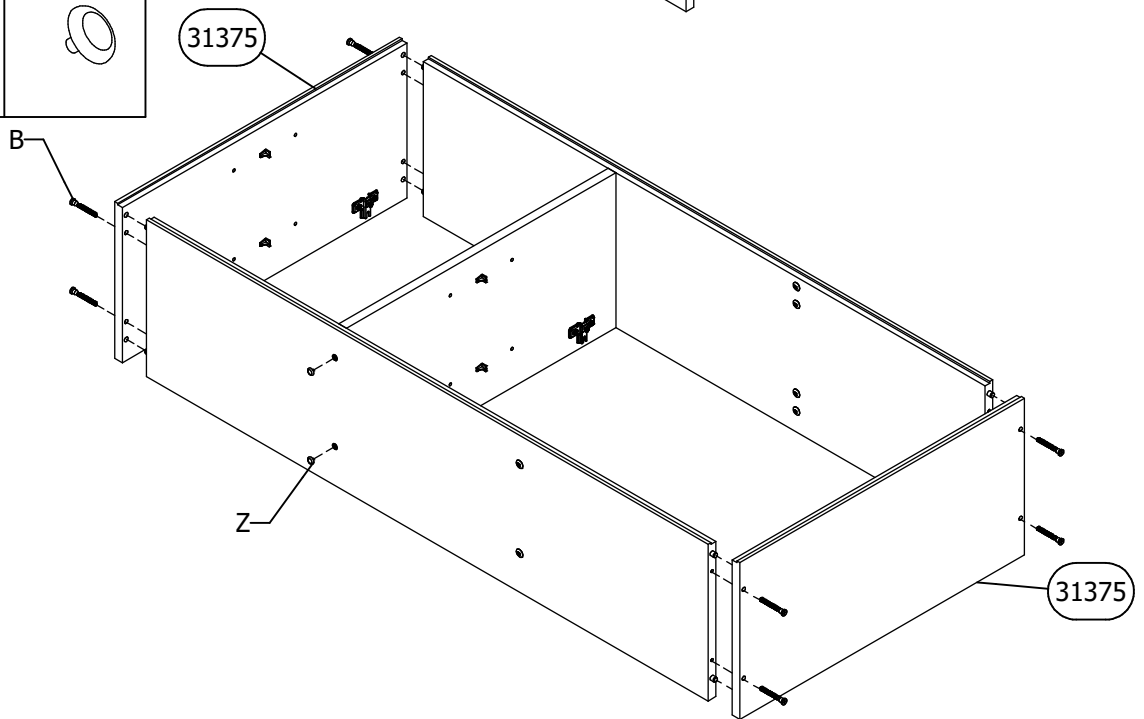

32 B x 8 Z x 2

 Ø7x50



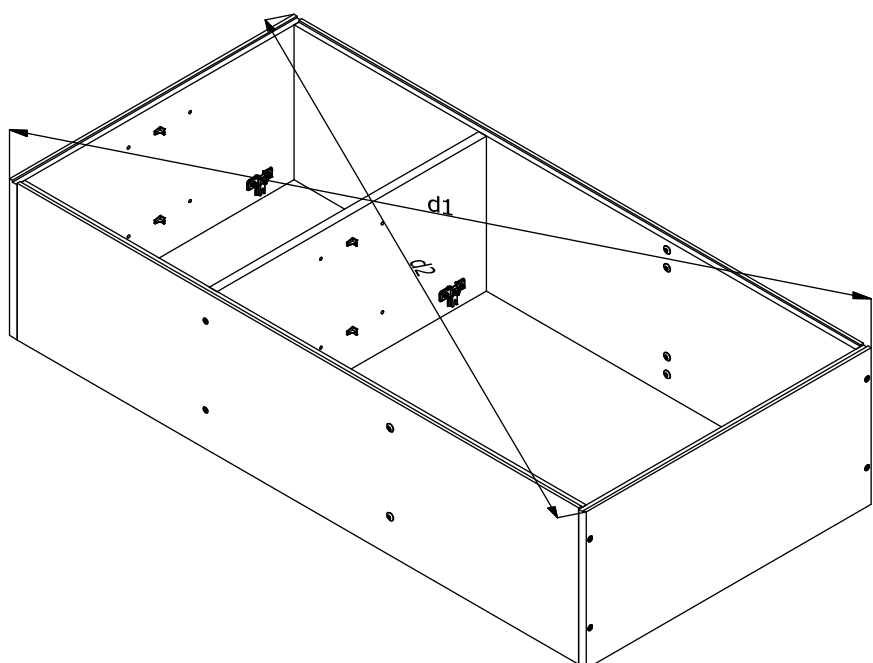

33

 d1 = d2



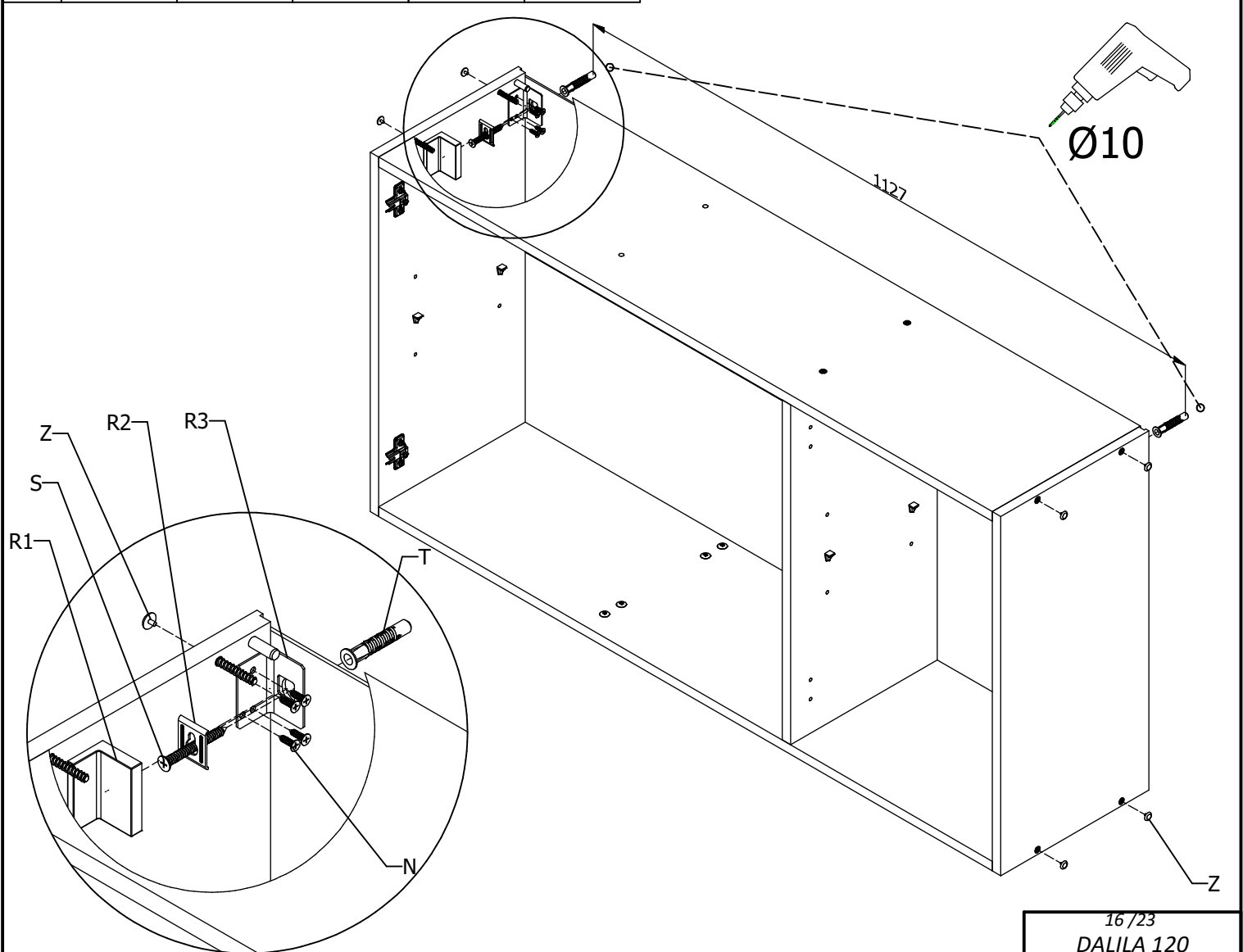
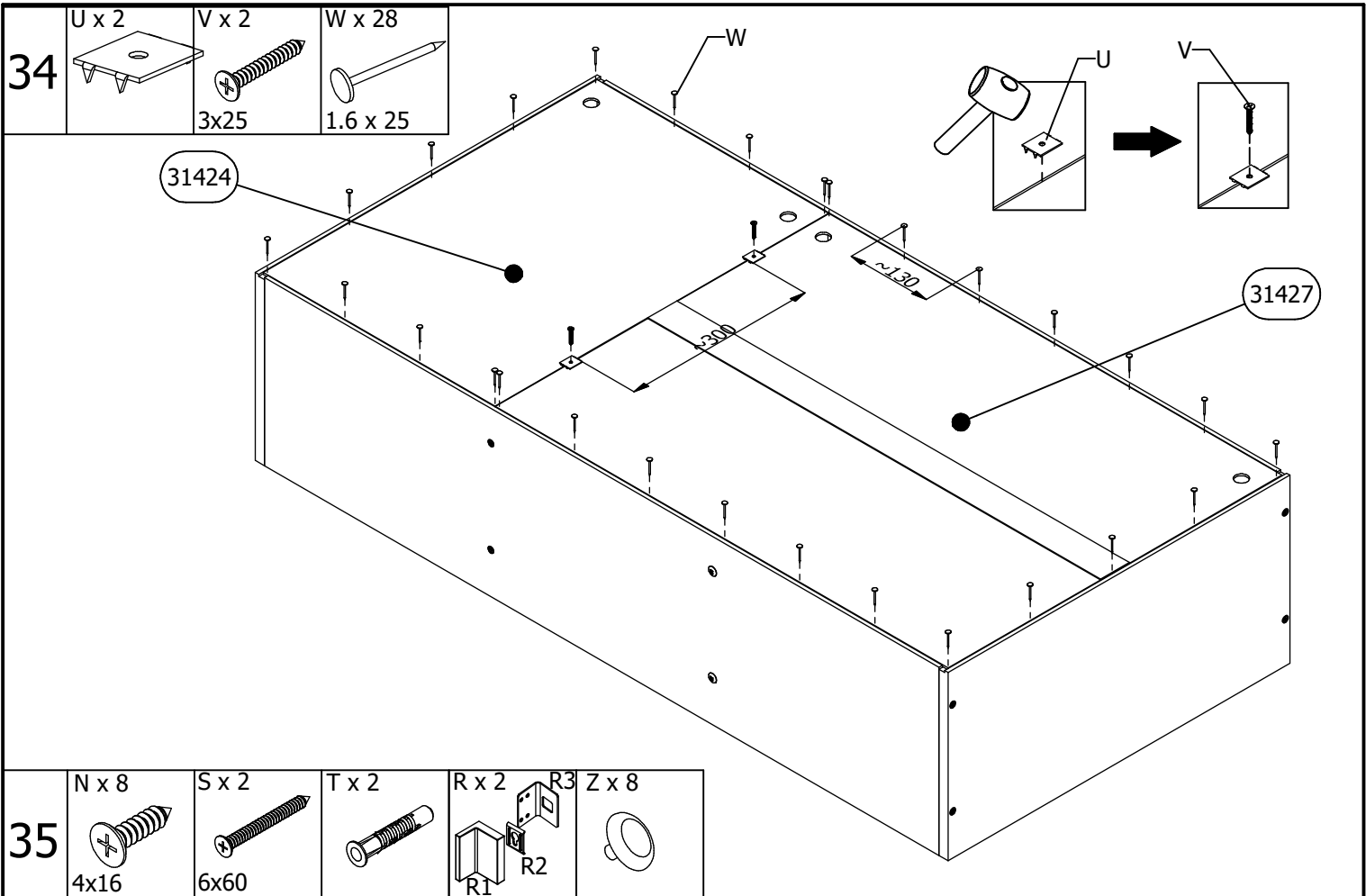

36

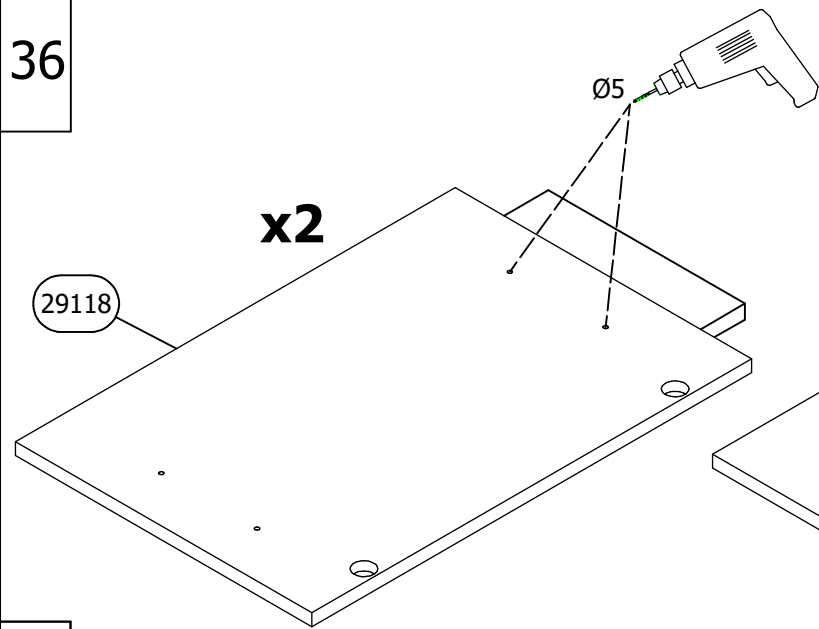

37

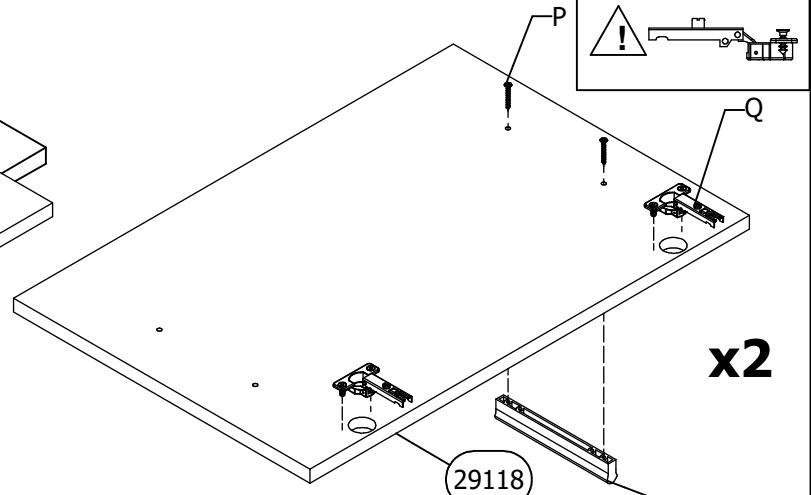
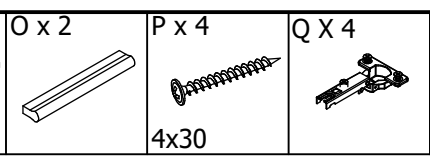

38

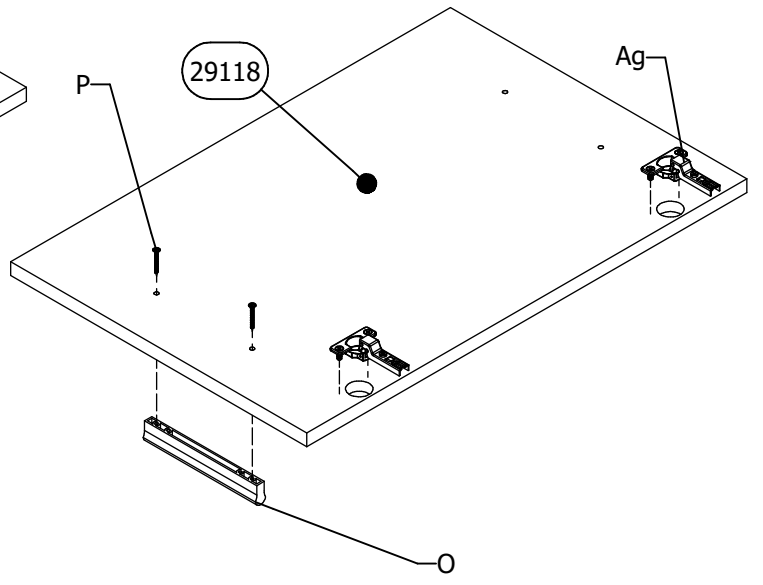
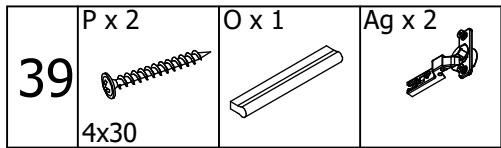
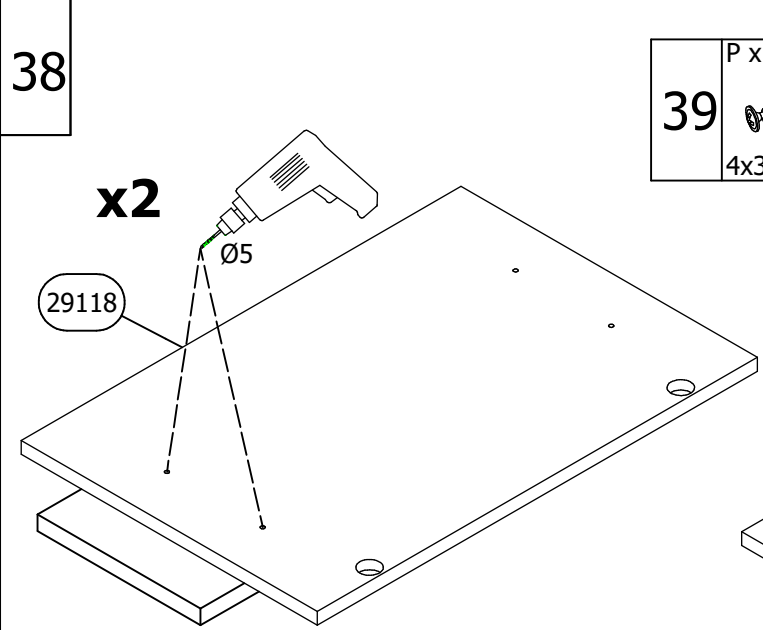

40

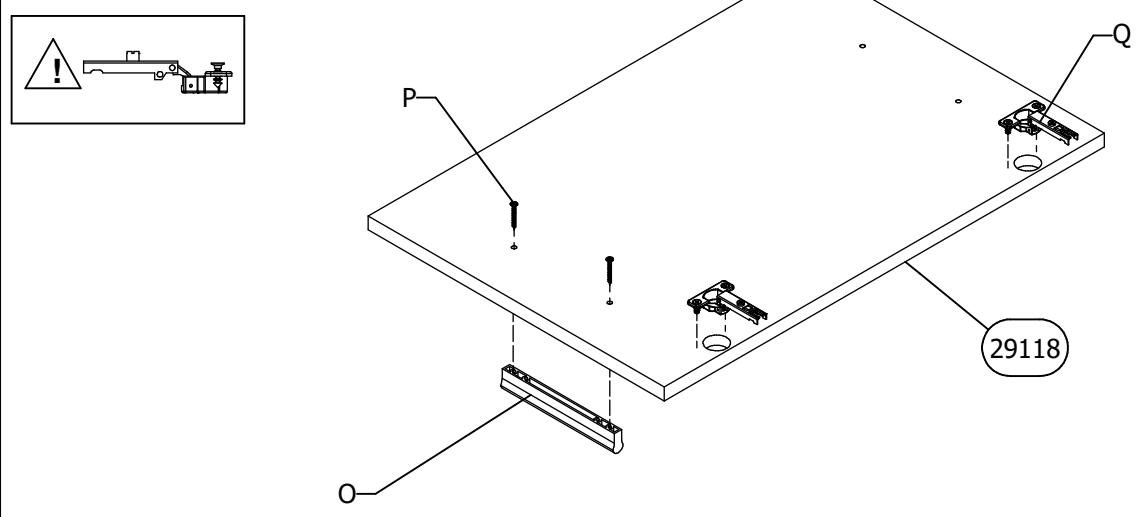
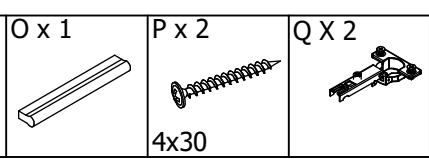

41 Ah x 4 Ak x 4

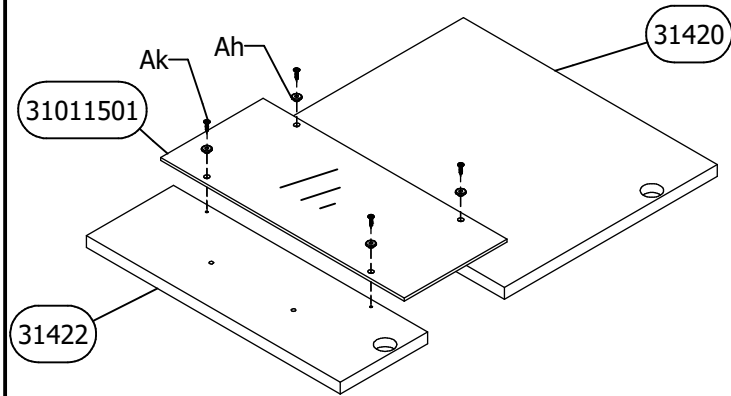

42 P x 2 O x 1 Q x 2
4x30

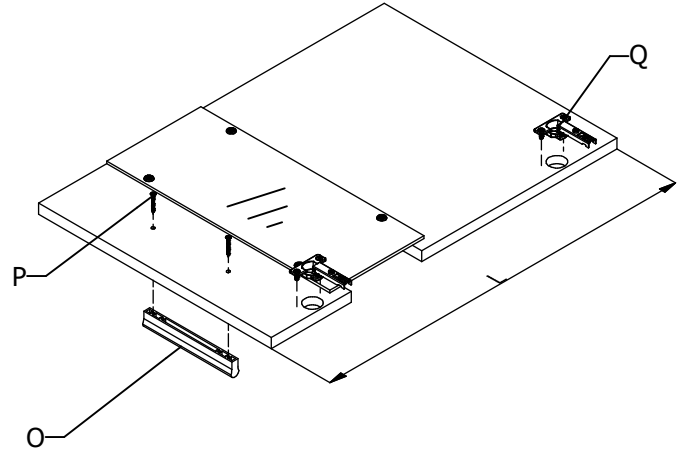
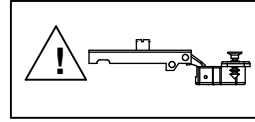

43 Ah x 4 Ak x 4

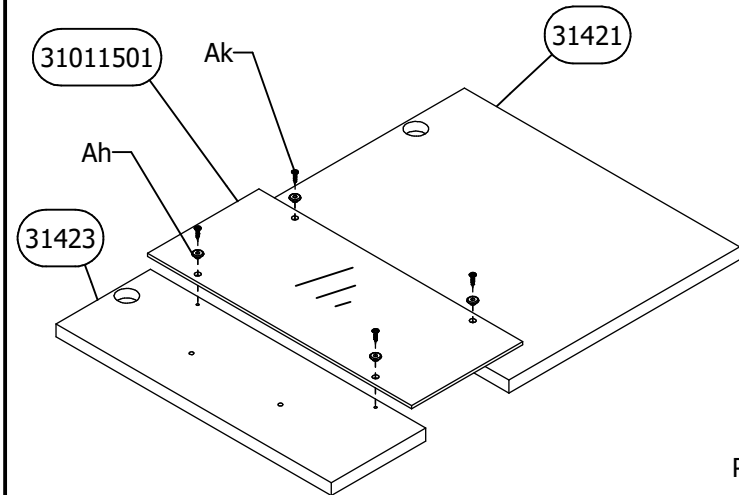

44 O x 1 P x 2 Q x 2
4x30

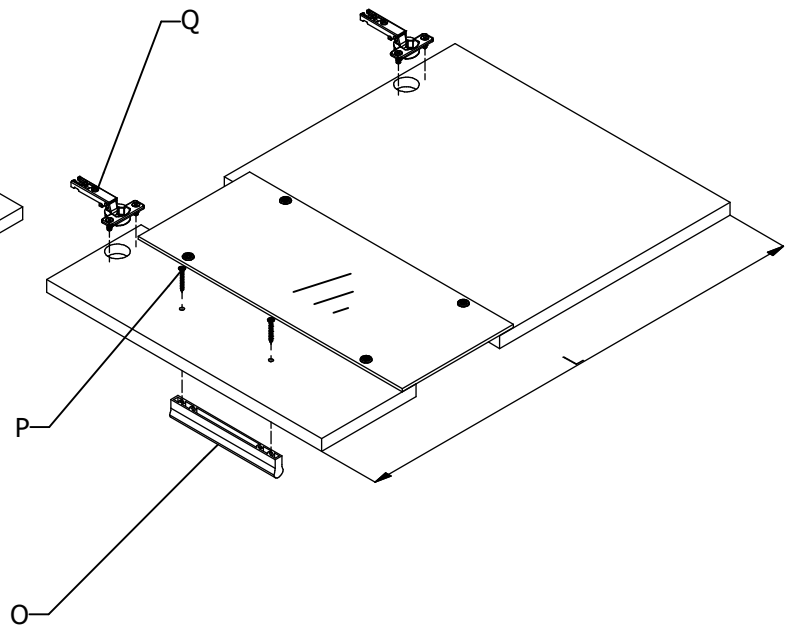
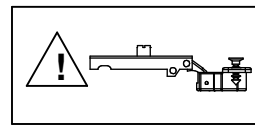

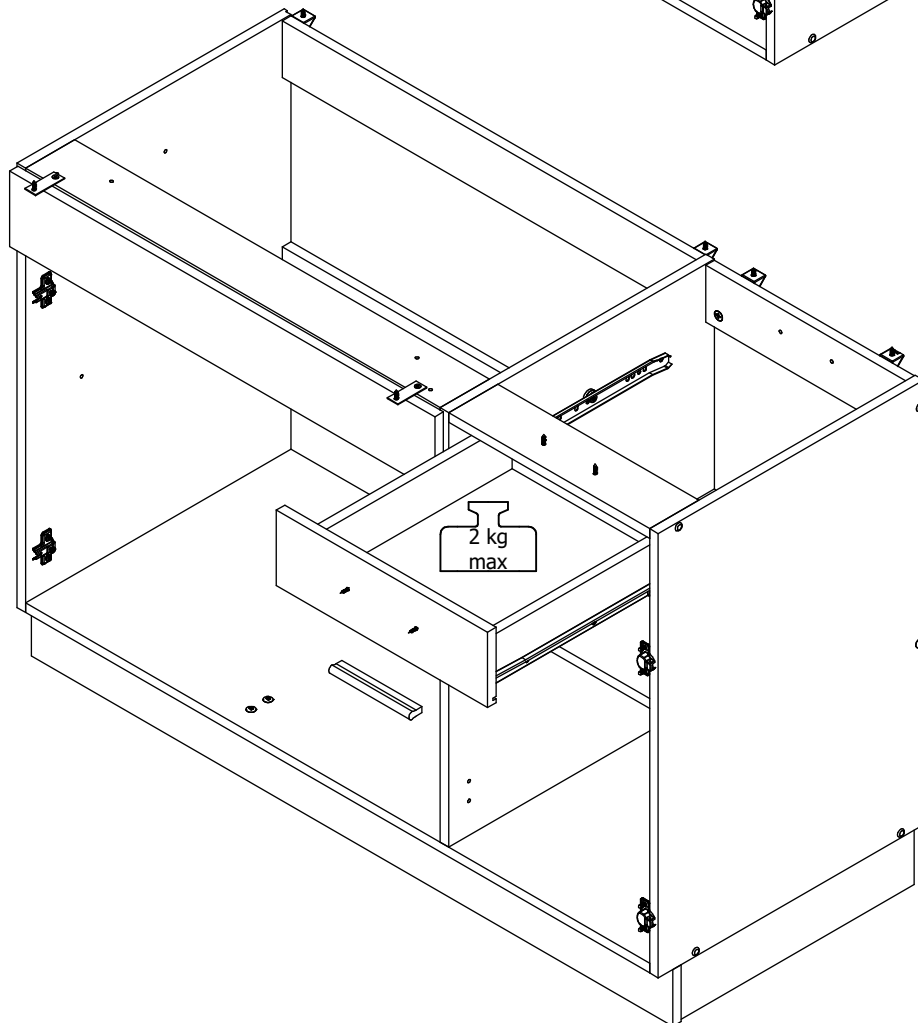
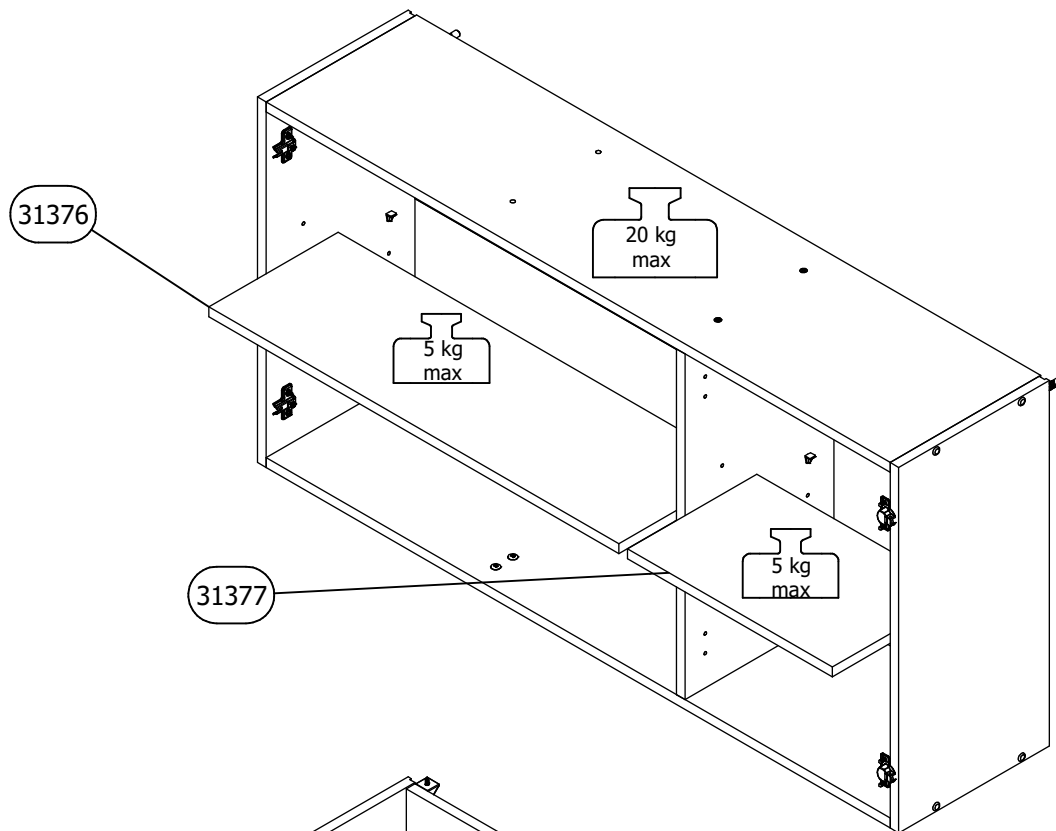

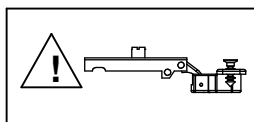
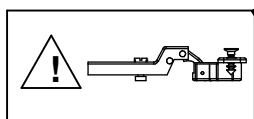
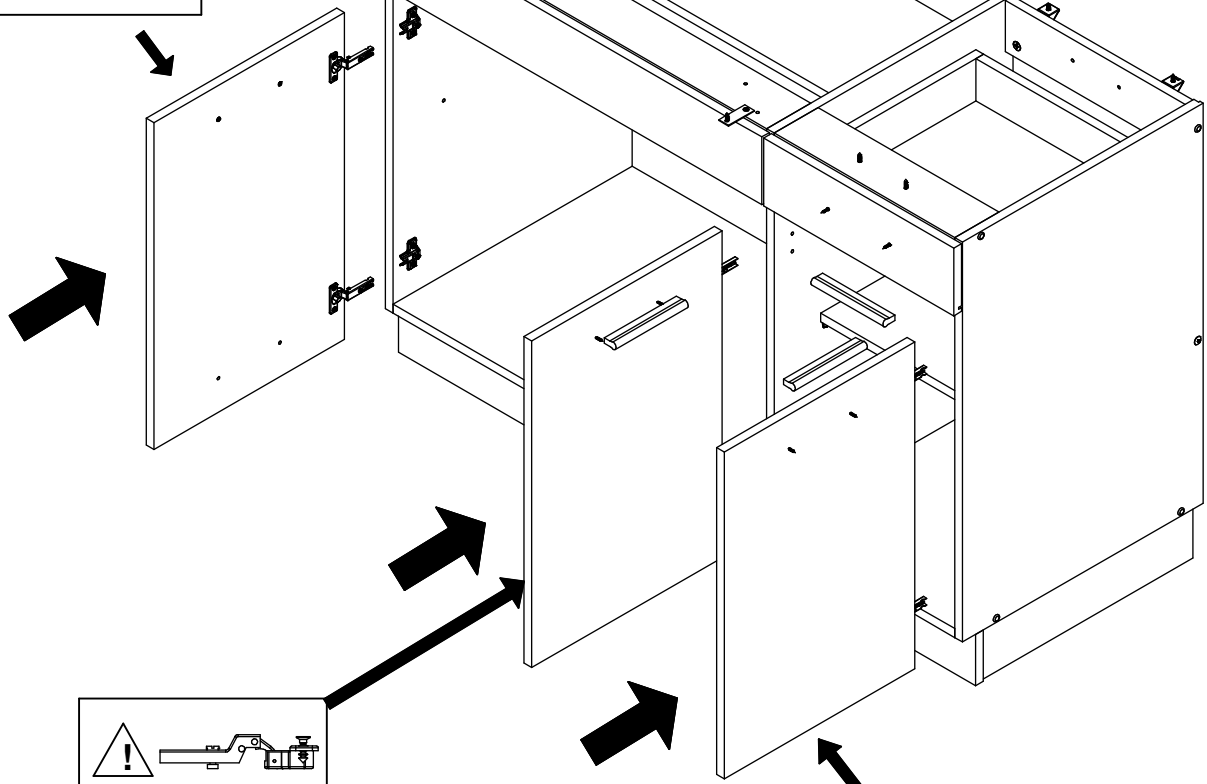
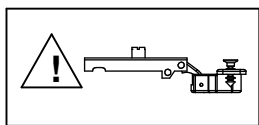
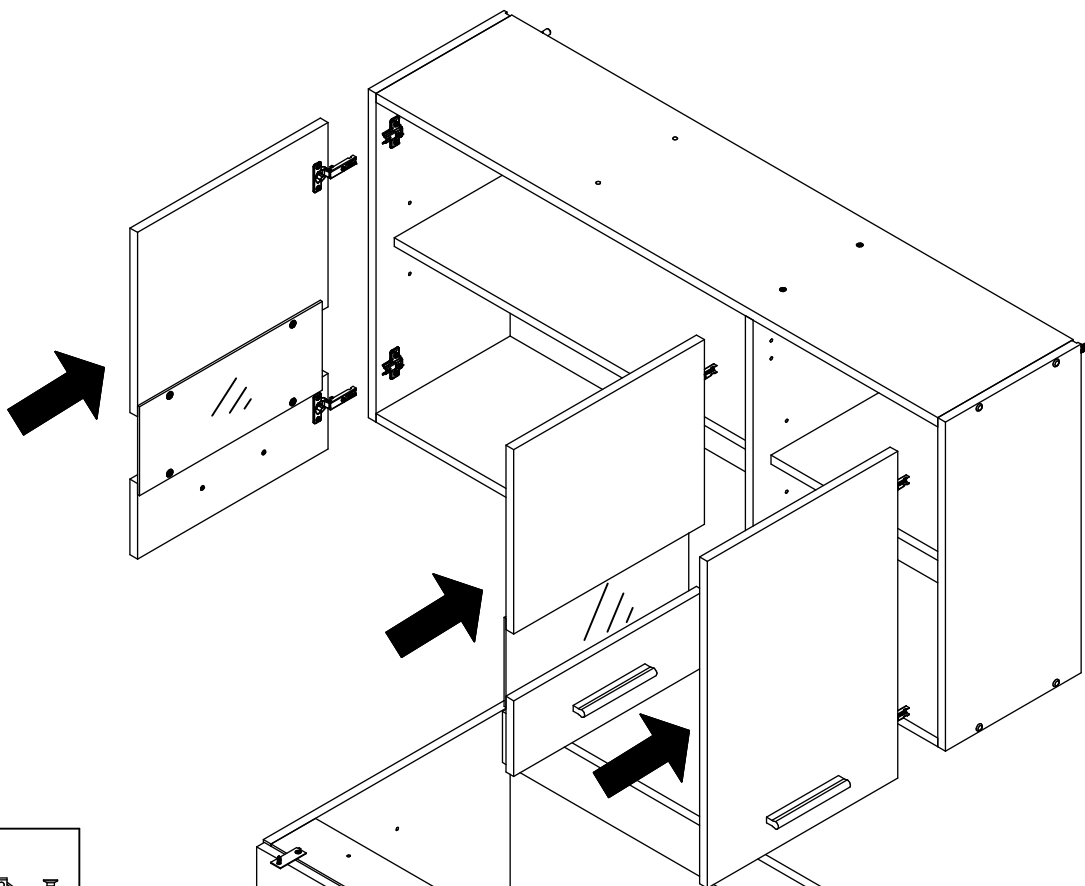

DALILA 120

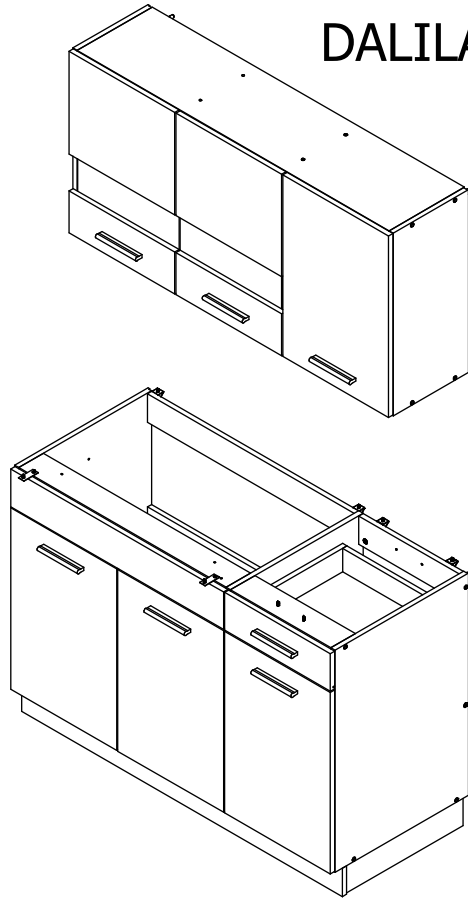

DALILA 200

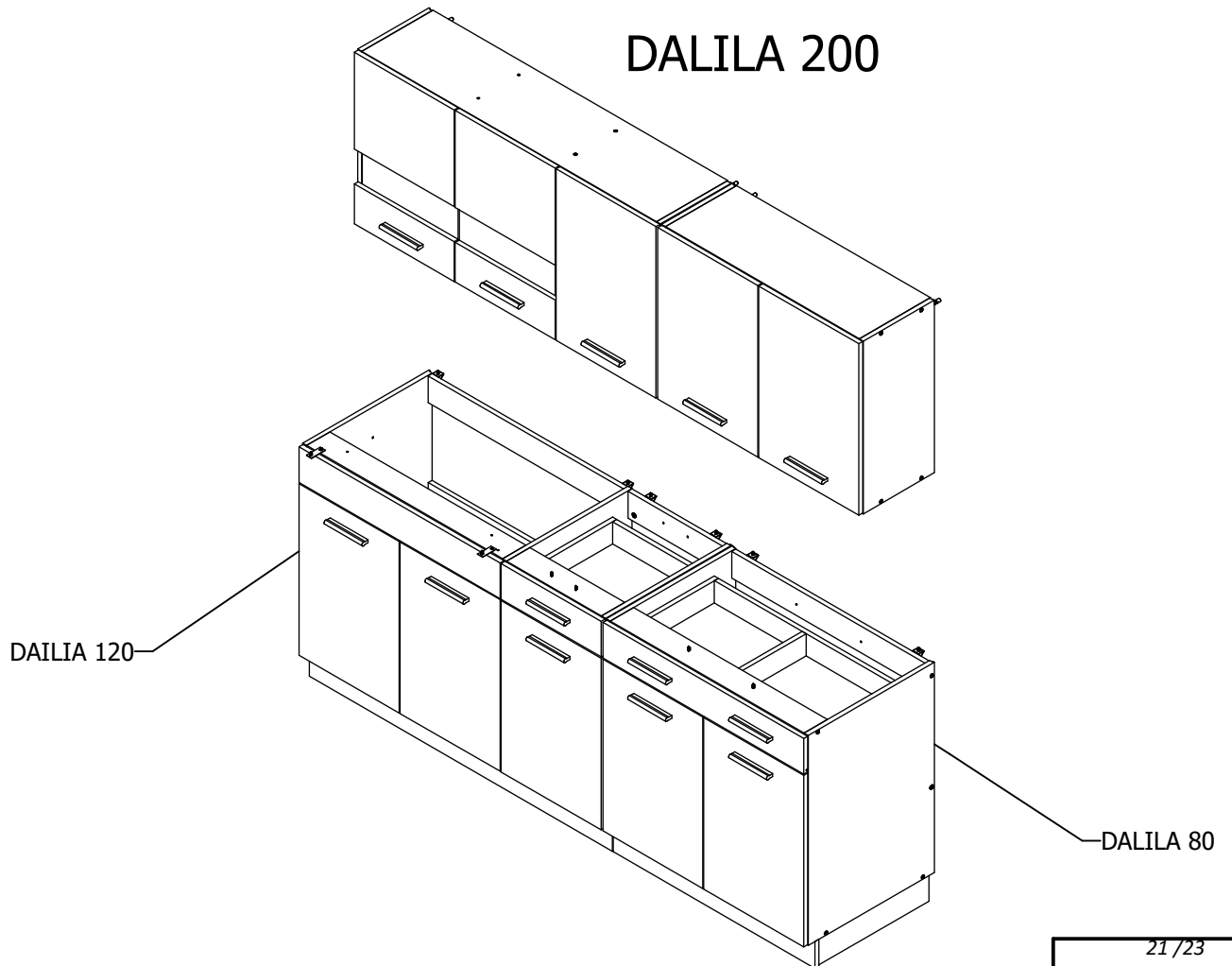

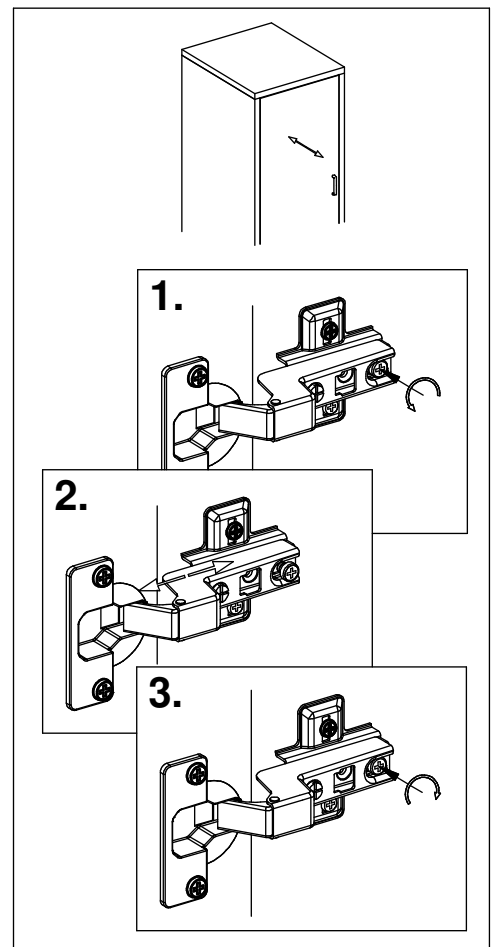
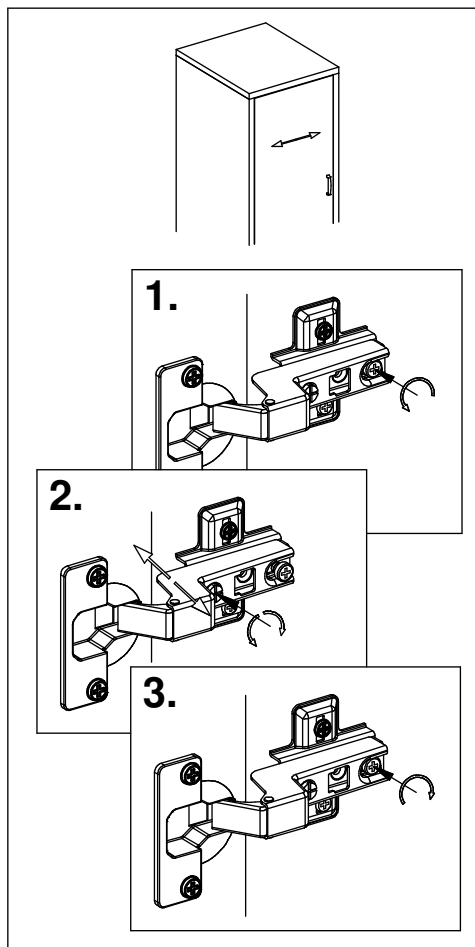
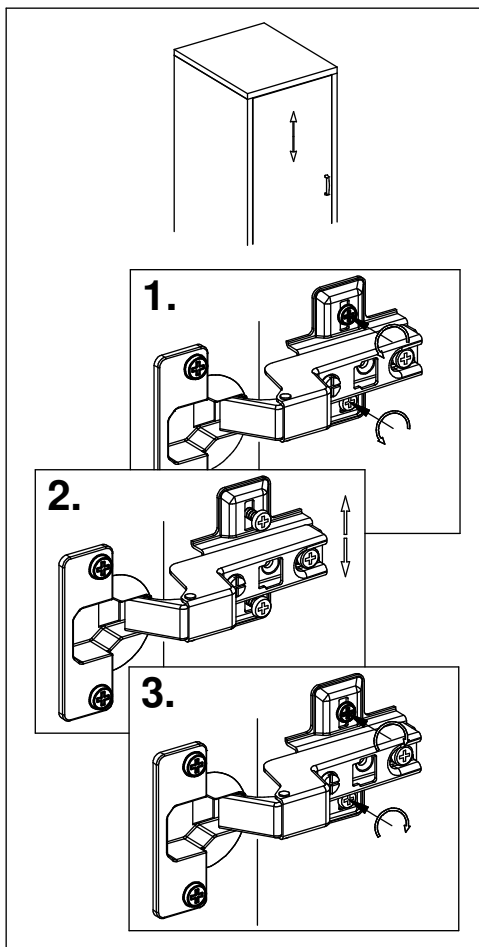
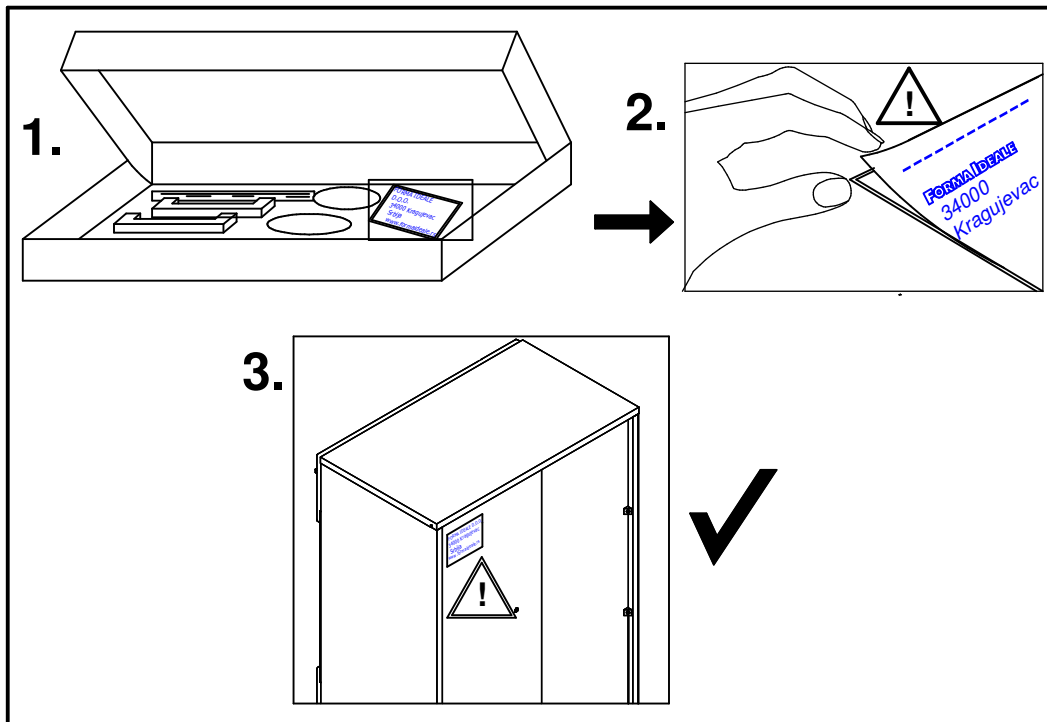



RS ME - UPOZORENJE! Poštovani kupci, kako bi izbegli moguće štete i povrede usled pada proizvoda, molimo Vas da se pridržavate uputstva za pričvršćivanje proizvoda za zid.

UK - ATTENTION! Dear customers, in order to avoid possible damages and injuries due to the fall of the product, please observe the assembly instructions for fixing the products to the wall.

DE AT CH - KIPPSICHERUNG! Sehr geehrte Kunden, um mögliche Schäden und Verletzungen durch den Fall des Produktes zu vermeiden, beachten Sie bitte die Montageanleitung zur Befestigung der Produkte an der Wand.

CZ - UPOZORNĚNÍ! Vážení kupci, abyste předešli možnému poškození a zranění v důsledku pádu výrobku, prosíme, dodržujte pokyny pro upevnění výrobku na zeď.

ES - ATENCIÓN! Estimados clientes, a fin de evitar posibles daños y lesiones debido a la caída del producto, le rogamos que siga las instrucciones para fijar el producto a la pared.

RUS BLR - ВНИМАНИЕ! Уважаемые покупатели, во избежание возможного ущерба и повреждения вследствие падения продукта просим Вас соблюдать инструкцию по приклеплению продуктов к стене.

EL - ΠΡΟΣΟΧΗ! Αξιότιμοι πελάτες, προκειμένου να αποφύγετε τυχόν ζημιές και τραυματισμούς από την πτώση του προϊόντος, σας παρακαλούμε να ακολουθήσετε τις οδηγίες για στερέωση του προϊόντος στον τοίχο.

BG - ВНИМАНИЕ! Уважаеми клиенти, за да избегнете евентуални повреди и наранявания, причинени от падането на продукта, спазвайте инструкциите за закрепване на продукта към стената.

SL - POZOR! Spoštovani kupci, da bi se izognili morebitnim škodam in poškodbam zaradi padca izdelka, vas prosimo, da upoštevate navodila za pritrditev izdelka na steno.

МК - ВНИМАНИЕ! Почитувани купувачи, за да ги избегнете можните штети и повреди предизвикани од пад на производот, Ве молиме да ги почитувате упатствата за прицврстување на производот на ѕид.

PL - UWAGA! Szanowni Klienci, w celu uniknięcia ewentualnych obrażeń ciała spowodowanych spadającymi przedmiotami, należy przestrzegać instrukcji mocowania produktu do ściany.

IT - ATTENZIONE! Gentili clienti, al fine di evitare eventuali danni o incidenti causati dalla caduta dei prodotti, siete pregati di seguire le istruzioni in merito alle modalità di affissione del prodotto sul muro.

SK - POZOR! Vážení zákazníci, aby ste predišli možnému poškodeniu a poraneniám v dôsledku spadnutia výrobku, dodržiavajte prosíme Vas pokyny na upevnenie výrobku na stenu.

RO - ATENȚIE! Dragi clienți, pentru a evita posibile pagube și vătămări datorită căderii produsului, vă rugăm să respectați instrucțiunile pentru fixarea produsului pe perete.

HR BIH - OPREZ! Poštovani kupci, kako bi se izbjegle moguće štete i ozljede uslijed pada proizvoda, pridržavajte se uputa za pričvršćivanje proizvoda na zid.

HU - FIGYELEM! Tisztelt vásárlók, a termék leesése következtében keletkező esetleges károk és sérülések elkerülése érdekében, kérjük, tartsák be a termék falra erősítésére szolgáló utasításokat.

AL - KUJDES! Klientë të dashur, me qëllim për të parandaluar dëmtime dhe lëndime të mundshme si pasojë e rënies së produktit, ju lutemi që të respektoni udhëzimet për fiksimin e produktit në mur.

PT - ATENÇÃO! Estimados clientes, Para evitar possíveis danos e ferimentos devido à queda do produto, siga as instruções para fixar o produto na parede.



RS ME
Dostavljeni plastični tiplovi su namenjeni za ugradnju na standardan zid od cigle.
Pre ugradnje korisnik je dužan da provjeri da li dos tavljeni tiplovi odgovaraju vrsti zida na koji je predviđena ugradnja.
Ukoliko tiplovi ne odgovaraju zidu kupac je u obavezi da u specijalizovanoj radnji sam nabavi odgovarajuće tiplove.

DE AT CH
Die gelieferten Plastikdübel sind zum Einbau in die standardmäßige Ziegelwand bestimmt.
Vor dem Einbau ist der Benutzer verpflichtet zu prüfen, ob die gelieferten Dübel der für den Einbau vorgesehenen Wandart entsprechen.
Wenn die Dübel der Wand nicht entsprechen, ist der Kunde verpflichtet, im Fachhandel entsprechende Dübel selbst zu besorgen.

ES
Las clavijas plásticas que se incluyen están previstas para ser insertadas en un muro de ladrillo estándar.
Antes de instalarlas, el usuario debe verificar si las clavijas proporcionadas son adecuadas para el tipo de muro previsto en que se propone insertarlas.
Si las clavijas no son adecuadas para el muro, el comprador debe adquirir por sí mismo las clavijas correspondientes en una tienda especializada.

RUS BLR
Входящие в комплект поставки пластиковые дюбели предназначены для монтажа на стандартную кирпичную стену.
До начала монтажа пользователь должен проверить соответствие поставленных дюбелей типу стены, на которую предусмотрен монтаж.
Если дюбели не соответствуют типу стены, покупатель должен в обязательном порядке приобрести соответствующие дюбели в специализированном магазине.

EL
Οι πλαστικές βύδες που παρέχονται προορίζονται για ενσωμάτωση σε συνωμάτωμο τοίχο από τούβλα.
Πριν από την ενσωμάτωση, ο χρήστης οφείλει να ελέγξει εάν οι βύδες που παρέχονται αντιστοιχούν στον τύπο του τοίχου στον οποίο προβλέπεται η ενσωμάτωση.
Εάν οι βύδες δεν ταιριάζουν στον τοίχο, ο αγοραστής υποχρεούται να προμηθευθεί κατάλληλες σε εξειδικευμένο κατάστημα.

BG
Доставените пластмасови дюбели са направени за вграждане в стандартна тухлена стена. Преди вграждането, ползувателят е длъжен да провери дали доставените дюбели съответстват на стената, за която са предвидени за вграждане. Ако дюбелите не съответстват на стената на купувача, то той задължително трябва да закупи съответни дюбели от специализирания магазин.

SL
Dostavljeni plastični nosilci so namenjeni za montažo na standardni zid iz opeke. Pred montažo je uporabnik dolžan preveriti, ali dostavljeni nosilci ustrezajo vrsti zidu, na katerem je predvidena montaža. V kolikor nosilci niso primerni, je kupec dolžan sam pri specializiranemu prodajalcu priskrbiti nosilce, ki ustrezajo montaži.

МК
Доставените пластични типли наменети се за прикачување на стандарден ѕид од цигла. Пред прикачувањето корисникот е должен да провери дали доставените типли одговараат на видот на ѕидот на кој е предвидено прикачувањето. Доколку типлите не одговараат купувачот е должен сам да набави во специјализирана продавница типли кои одговараат.

PL
Dołączone plastikowe kolki są przeznaczone do montażu na standardową ścianę z cegły.
Przed zamontowaniem, użytkownik jest zobowiązany upewnić się, czy załączone kolki odpowiadają typowi ściany na której jest przewidziany montaż.
W przypadku gdy kolki nie są odpowiednie do typu ściany, na którą ma być zamontowany regał, użytkownik jest zobowiązany, aby samemu zaopatrzyć się w odpowiedni typ kolców w sklepie specjalistycznym.



UK
Delivered plastic plugs are intended for fitting on a standard brick wall.
Before fitting, the buyer needs to check if the delivered plugs are suitable for the wall they are foreseen for.
If the plugs are not suitable for the wall, buyers have to visit a specialized store and get suitable plugs by themselves.

IT CH
I tasselli di plastica consegnati sono destinati al montaggio su un muro di mattoni standard.
Prima del loro montaggio, l'acquirente deve controllare se i tasselli forniti sono adatti per la parete su cui si prevede di installarli.
Se i tasselli non sono adatti per questo tipo di parete, l'acquirente è tenuto ad acquistare i tasselli adeguati presso un negozio specializzato.

FR CH
Les chevilles en plastique fournies sont conçues à l'installation sur le mur standard en briques.
Avant l'installation, l'utilisateur est obligé de vérifier si les chevilles fournies correspondent bien au type de mur prévu pour l'installation.
Si les chevilles ne correspondent pas bien au mur, l'acheteur est obligé d'assurer lui-même les chevilles correspondantes dans un magasin spécialisé.

CZ SK
Dodané plastové hmoždinky jsou určeny pro montáž na standardní cihlovou stěnu. Před začátkem montáže, kupující je povinnen dohlédnout na správnost typu dodaných hmoždinek, vzhledem na typ stěny určené k montáži.
Pokud hmoždinky dodané výrobcem neodpovídají typu stěny určené k montáži, kupující je povinnen pořídit si správný typ ve specializované prodejně.

RO
Tiplurile din plastic transmise sunt prevăzute exclusiv pentru pereții standard din cărămidă.
Înainte de instalare beneficiarul este obligat să verifice dacă tiplurile transmise corespund peretelui pe care se prevede instalarea. În cazul în care tiplurile nu corespund peretelui, cumpărătorul este obligat să achiziționeze singur tiplurile corespunzătoare din magazinele specializate.

HR BIH
Dostavljeni plastični tiplovi su namijenjeni za ugradnju na standardan zid od cigle. Prije ugradnje korisnik je dužan da provjeri da li dostavljeni tiplovi odgovaraju vrsti zida na koji je predviđena ugradnja.
Ukoliko tiplovi ne odgovaraju zidu kupac je u obavezi da u specijaliziranoj radnji sam nabavi odgovarajuće tiplove.

HU
A kézbesített műanyag tiplik standard téglafalra való beépítésre szolgálnak. Beépítés előtt a felhasználó köteles leellenőrizni, hogy a tiplik megfelelnek-e a falajtájának, amelyre a beépítés szánták.
Ha a tiplik nem felelnek meg, a vásárló köteles a megfelelőket szaküzletben beszerezni.

AL
Ankorat e dhëna plastike janë të dizajnuara për instalim në mur standard me tulla. Para instalimit përdoruesi duhet të verifikojë nëse ankorat e dërguara iu përshtaten llojit të murit në të cilin është parashikuar të bëhet instalimi.
Nëse ankorat nuk iu përshtaten murit, blerësi është i obliguar që vetë të blejë ankorat e duhura në shitoren e specializuar.

PT
As buchas plásticas fornecidas destinam-se à instalação numa parede de tijolos padrão.
Antes da instalação, é obrigada a verificar se as buchas fornecidas correspondem ao tipo de parede em que instalação está prevista.
Se as buchas não forem as mais indicadas à parede, será da responsabilidade do cliente a compra das buchas apropriadas em uma loja especializada.