

Ax1

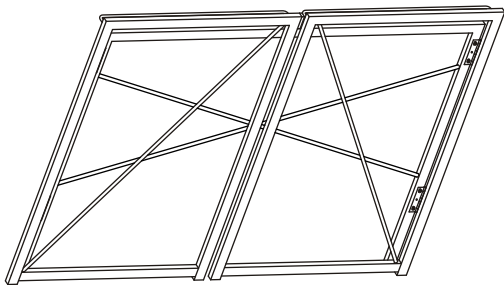

Bx1



1

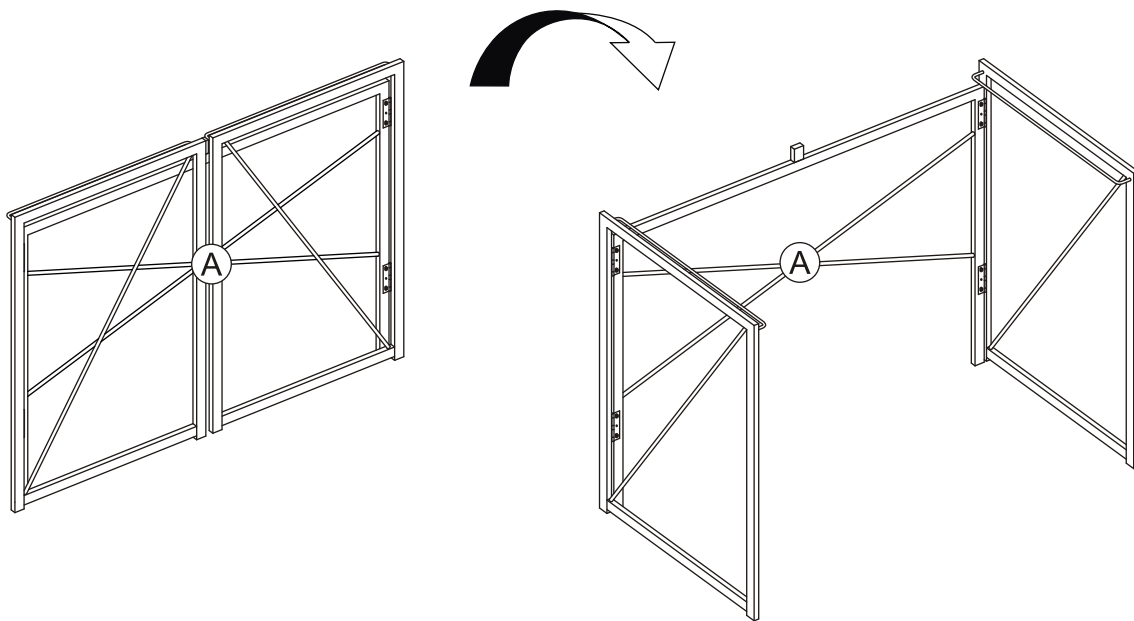

2

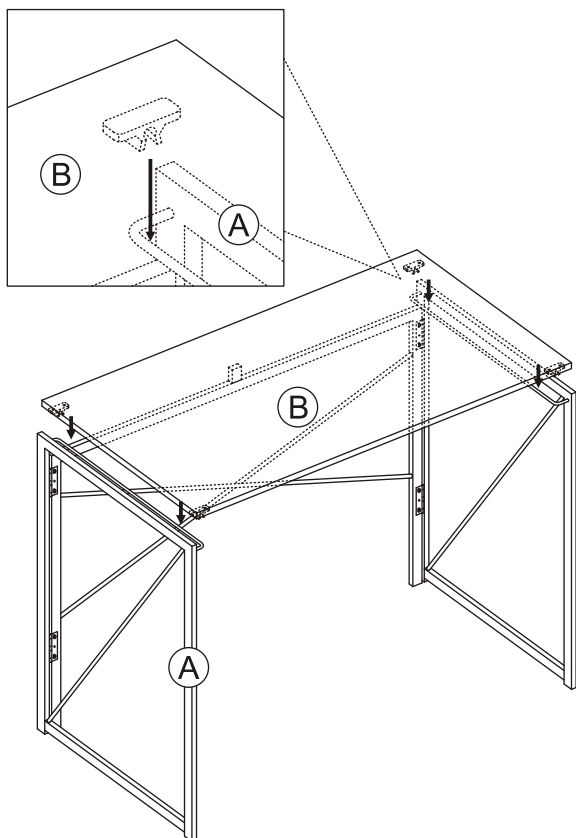

3

