

0201EN3PK

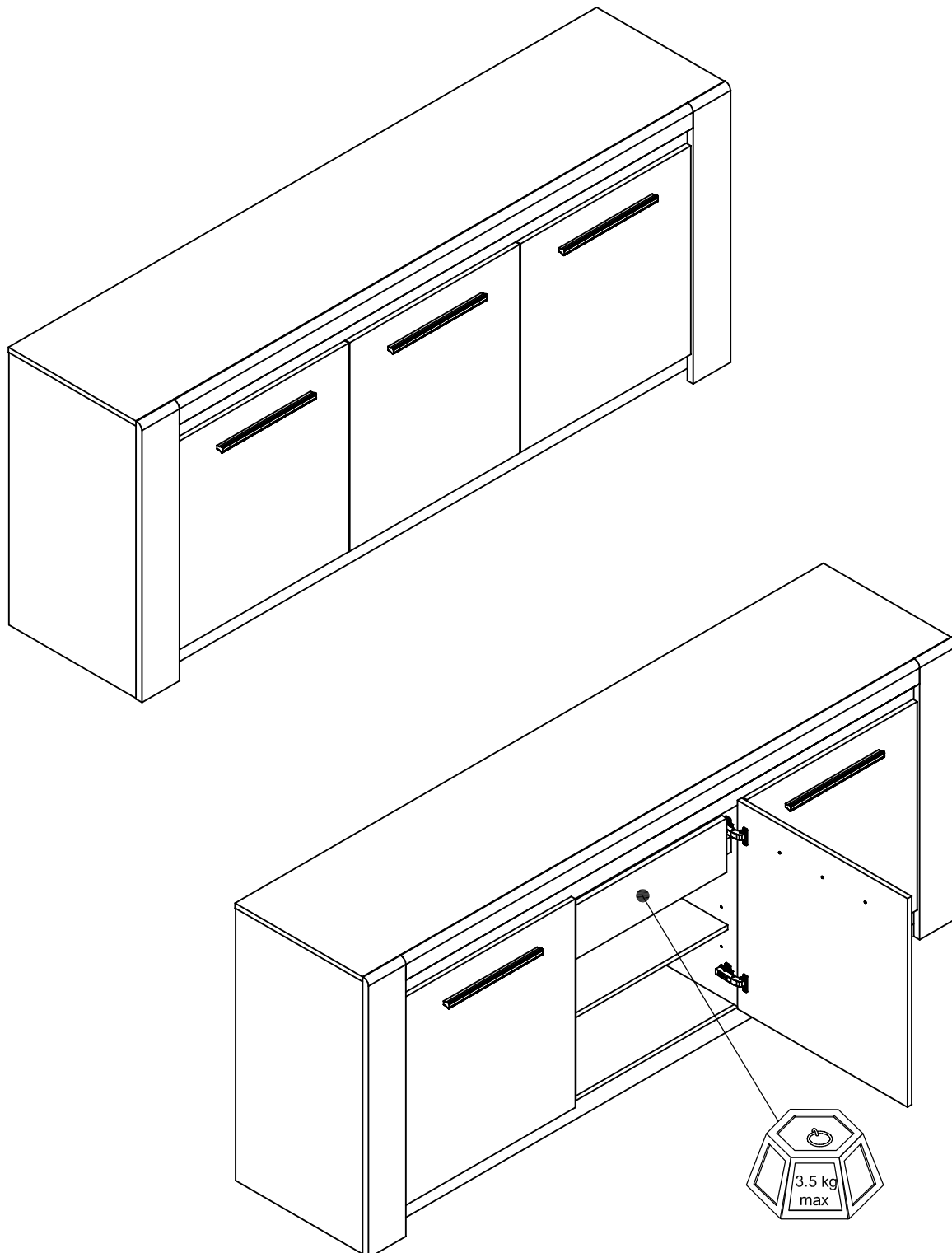

Code: 0201EN3PK - 725510

Décor/Finitions: Mélaminé blanche / Mélaminé gris béton / Laqué blanche HB

Gamme: PEGASE

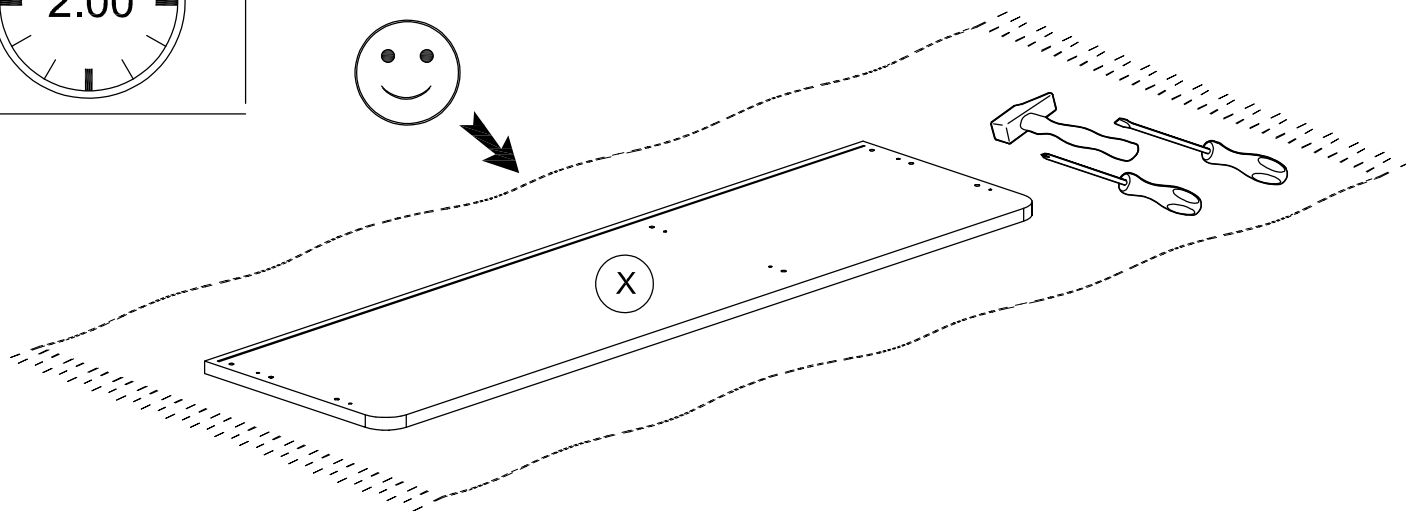
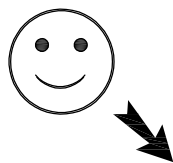
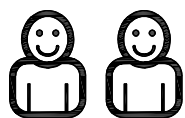
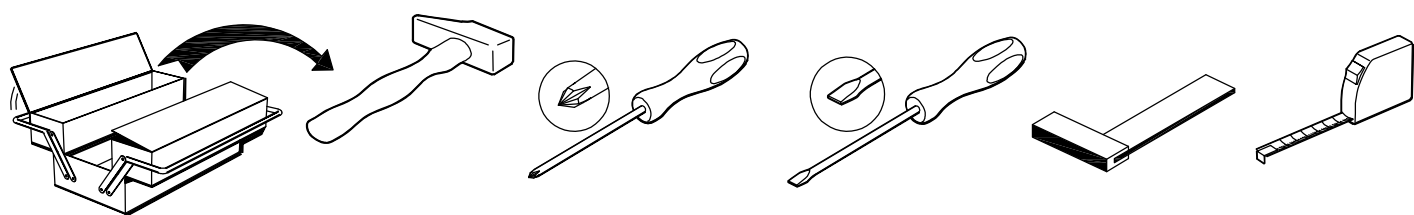

0201EN3PK

90 cm
35 7/16"

220 cm
86 5/8"

50 cm
19 11/16"

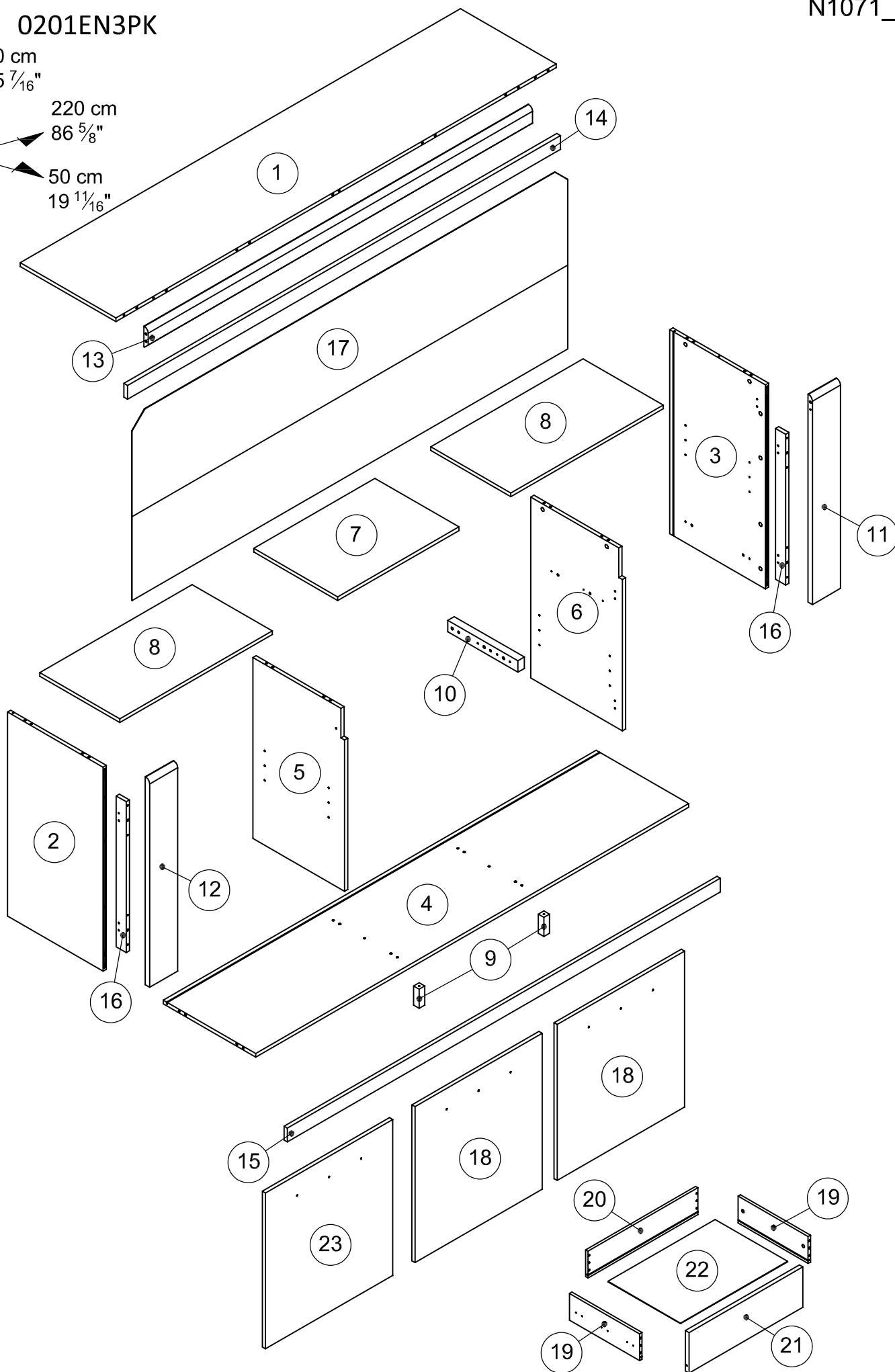

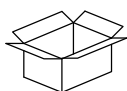

0201EN3P1

0201EN3P1			mm			inch					
9	x	2	83	29	29	3	1/4"	1	1/8"	1	1/8"
10	x	1	350	50	32	13	3/4"	1	15/16"	1	1/4"
16	x	2	653	50	16	25	11/16"	1	15/16"	0	5/8"
18	x	2	675	636	16	26	9/16"	25	1/16"	0	5/8"
19	x	2	350	116	12	13	3/4"	4	9/16"	0	1/2"
20	x	1	549	116	12	21	5/8"	4	9/16"	0	1/2"
21	x	1	569	175	18	22	3/8"	6	7/8"	0	11/16"
22	x	1	535	362	2.5	21	1/16"	14	1/4"	0	1/8"
23	x	1	675	636	16	26	9/16"	25	1/16"	0	5/8"



0201EN3P2

0201EN3P2			mm			inch					
1	x	1	2200	478	16	86	5/8"	18	13/16"	0	5/8"
4	x	1	2164	462	16	85	3/16"	18	3/16"	0	5/8"
11	x	1	900	140	22	35	7/16"	5	1/2"	0	7/8"
12	x	1	900	140	22	35	7/16"	5	1/2"	0	7/8"
13	x	1	1921	90	22	75	5/8"	3	9/16"	0	7/8"
14	x	1	2164	60	18	85	3/16"	2	3/8"	0	11/16"
15	x	1	2164	60	16	85	3/16"	2	3/8"	0	5/8"
17	x	1	2178	797	5	85	3/4"	31	3/8"	0	3/16"

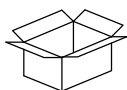

0201EN3P3

0201EN3P3			mm			inch					
2	x	1	883	478	16	34	3/4"	18	13/16"	0	5/8"
3	x	1	883	478	16	34	3/4"	18	13/16"	0	5/8"
5	x	1	783	458	16	30	13/16"	18	1/16"	0	5/8"
6	x	1	783	458	16	30	13/16"	18	1/16"	0	5/8"
7	x	1	606	420	16	23	7/8"	16	9/16"	0	5/8"
8	x	2	761.5	400	16	30	"	15	3/4"	0	5/8"

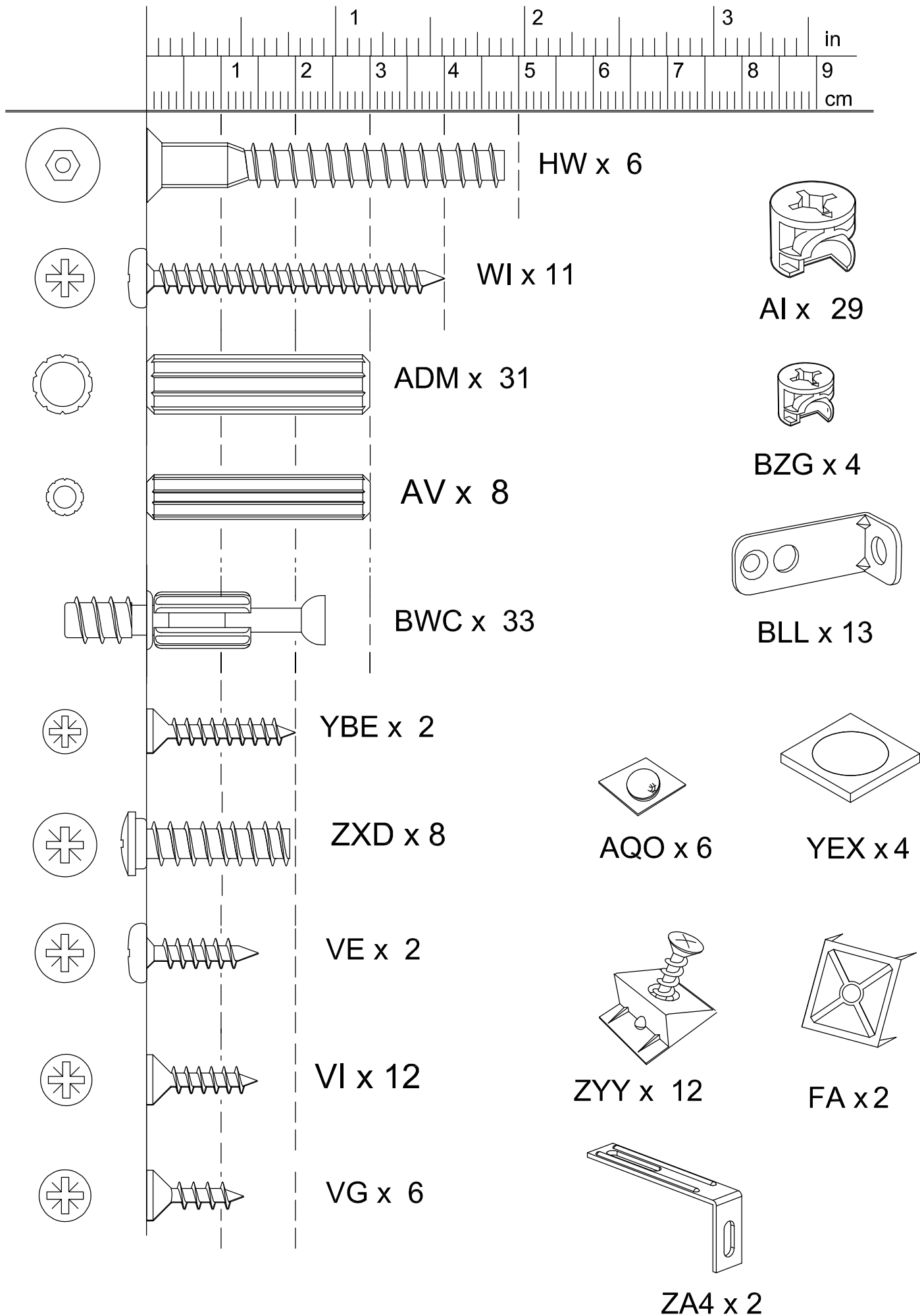

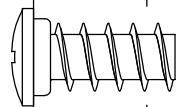
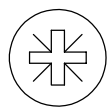
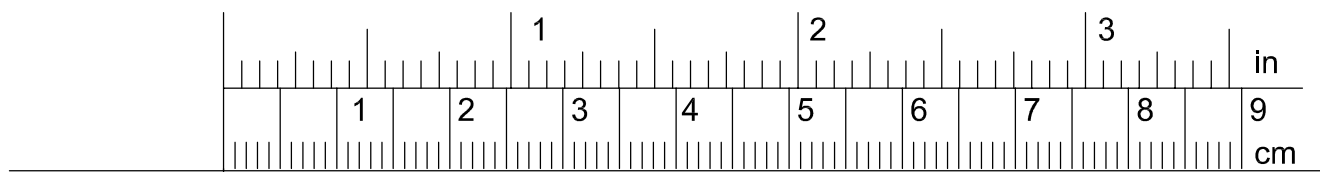

VB x 26

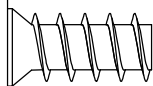

BWF x 6

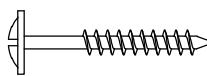

WH x 3

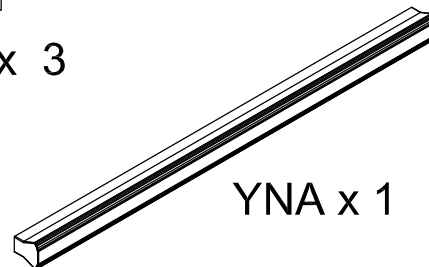

YNA x 1

x 3

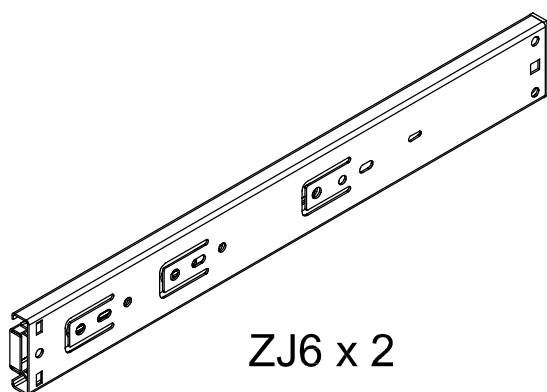

ZJ6 x 2

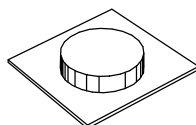

ZRV x 8

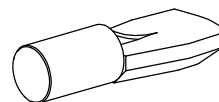

BWD x 12

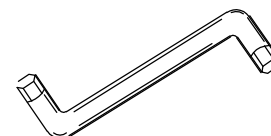

HV x 1

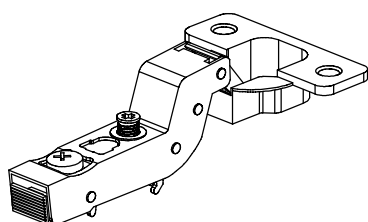

YMF x 4

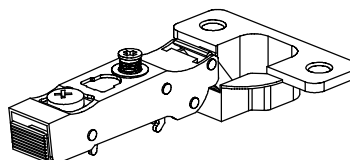

YMD x 2

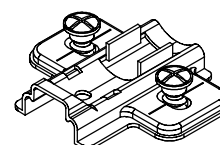

YME x 6

1

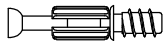

BWC x 4



ADM x 4

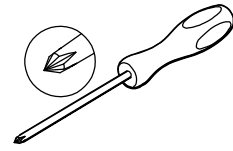

N1071_03

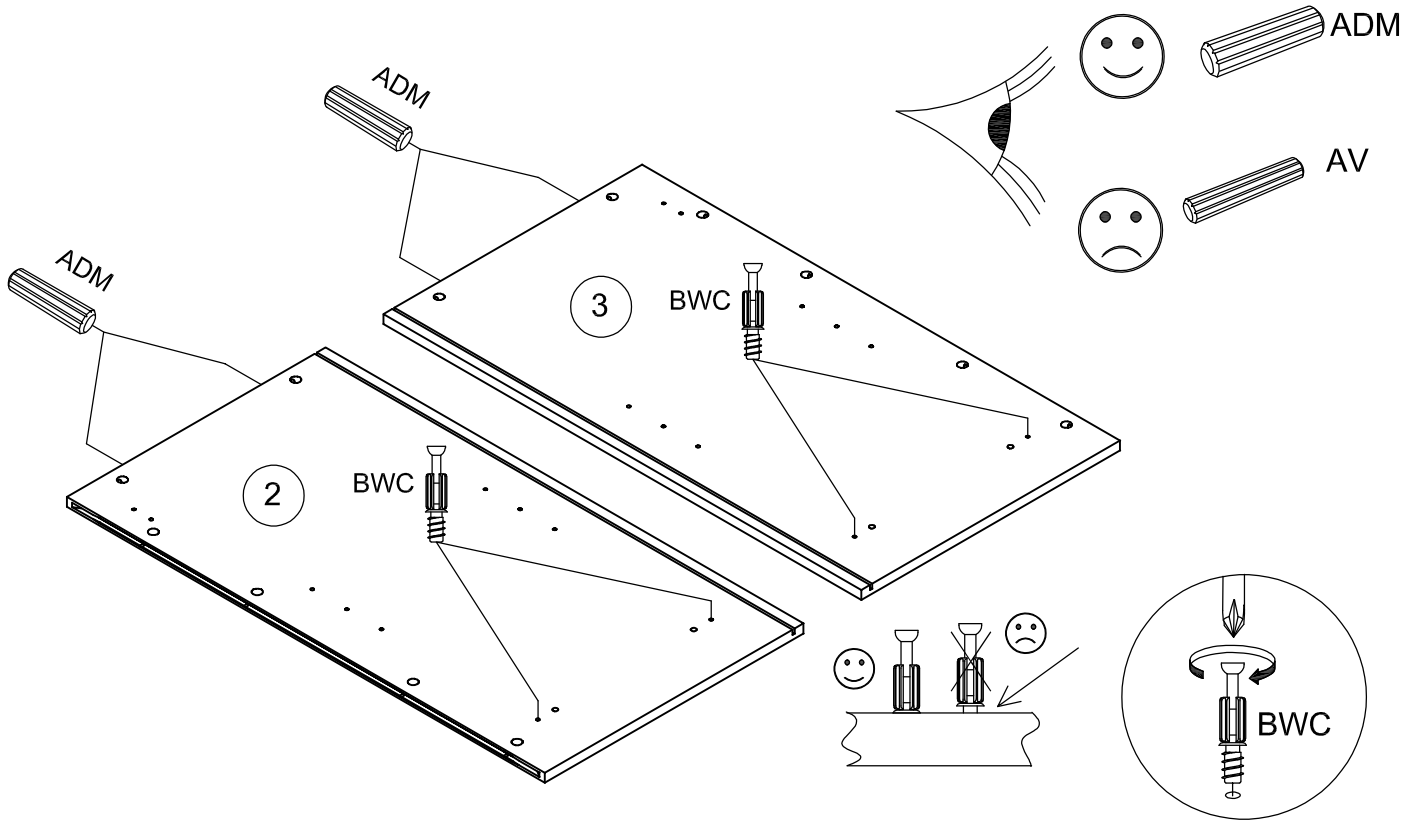

2

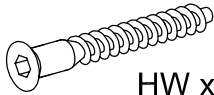

HW x 2



ADM x 4



HV x 1

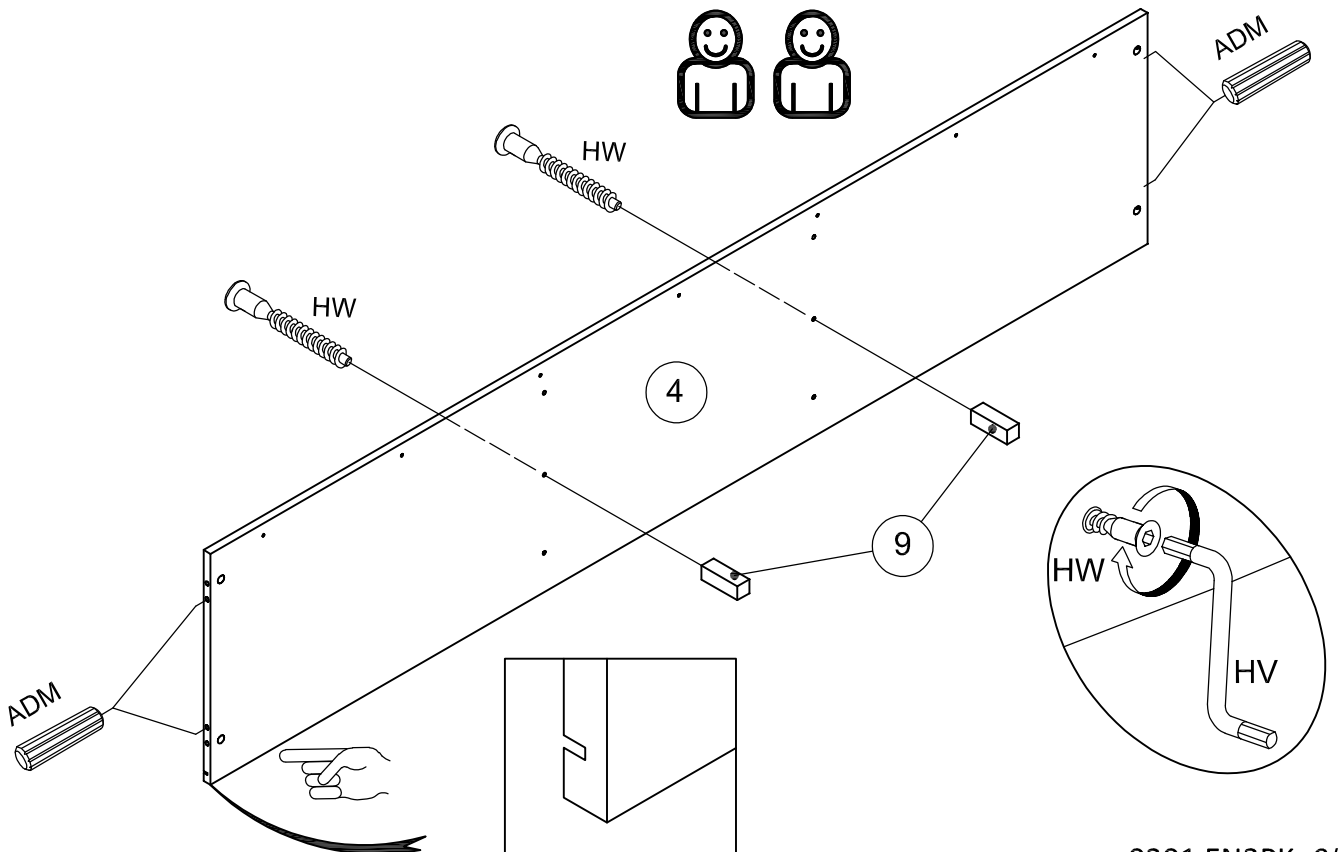

3

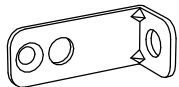

BLL x 13

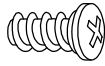

VB x 13

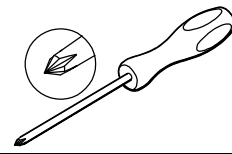

N1071_03

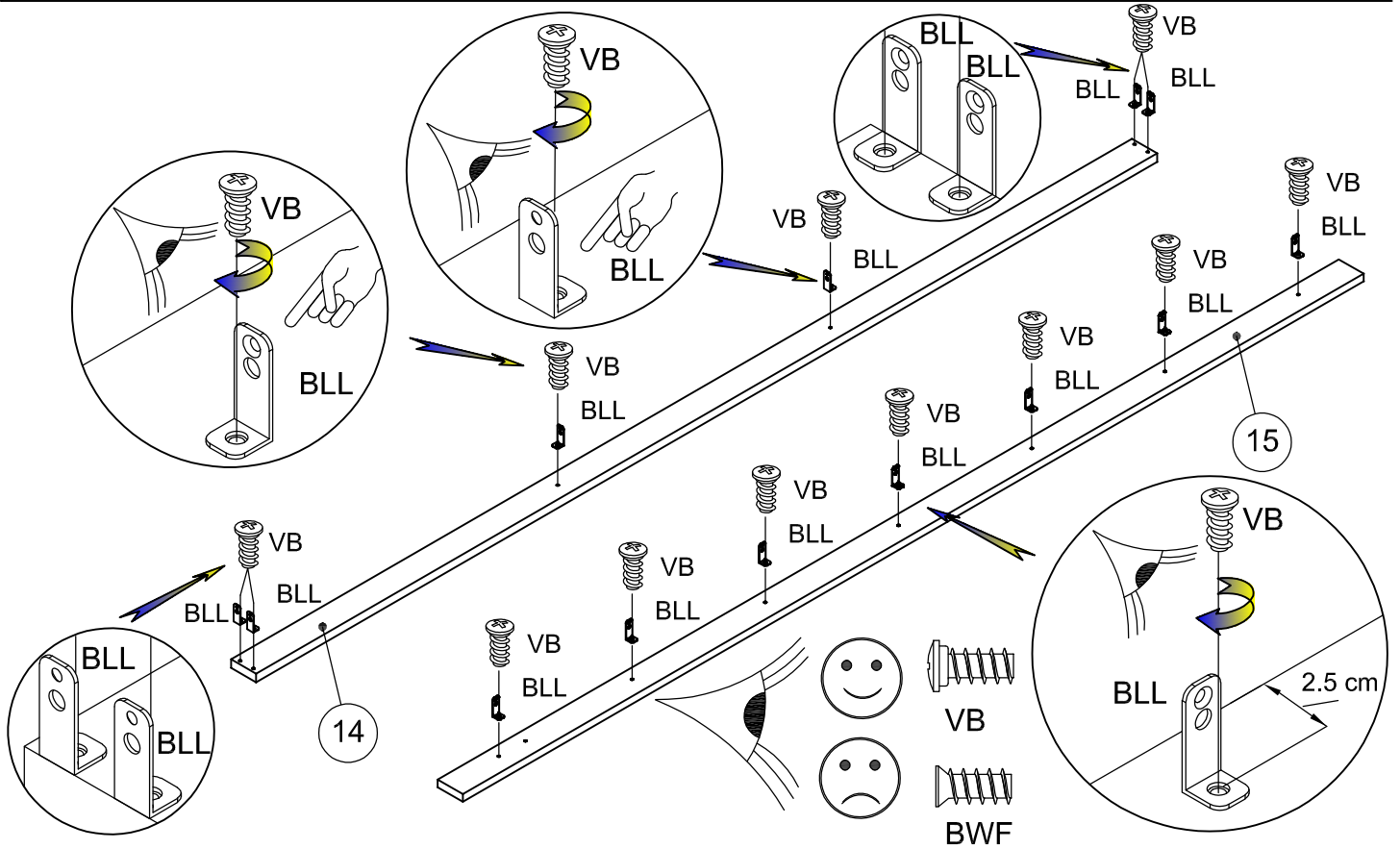

4

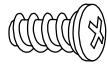

VB x 7

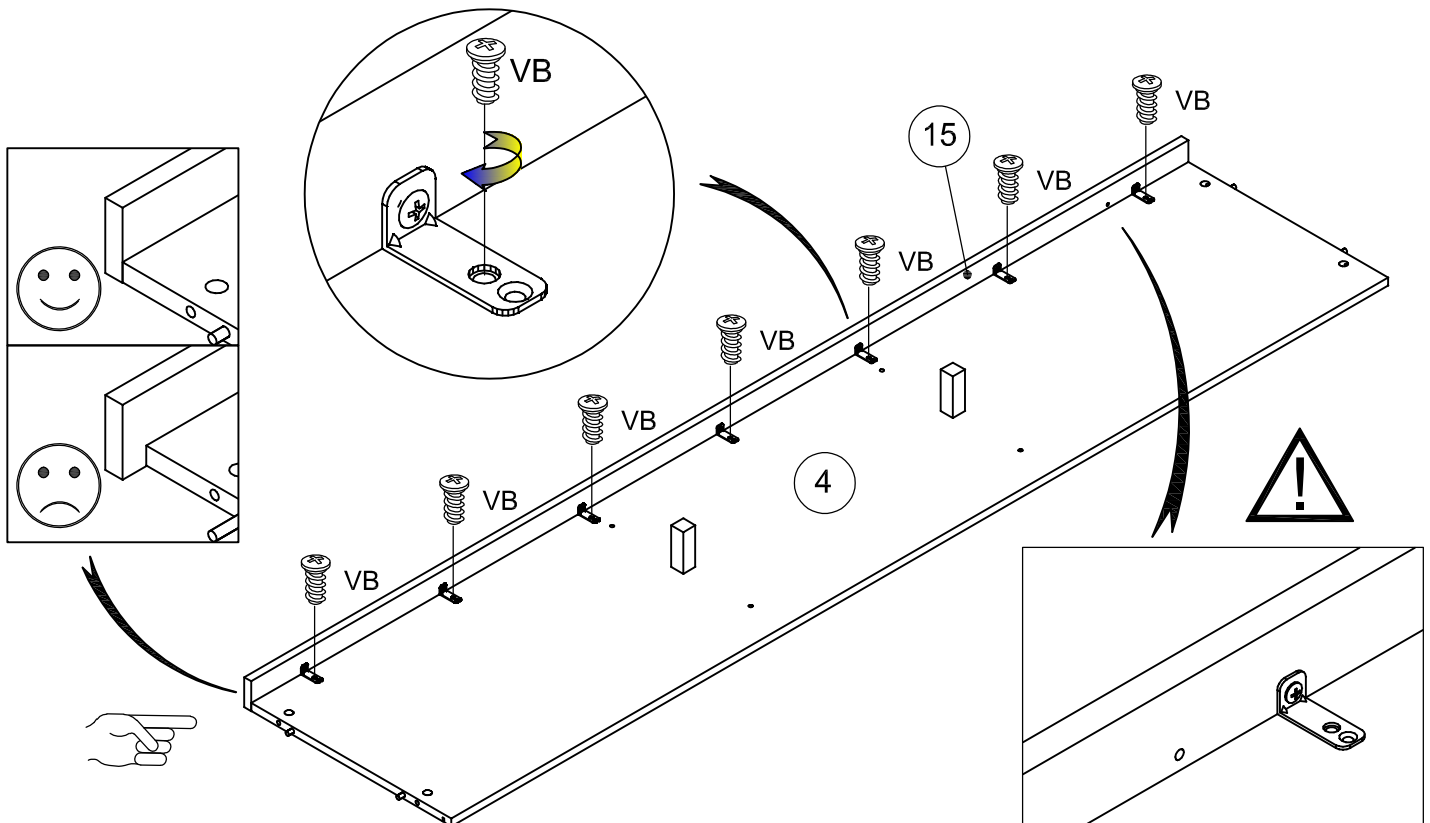
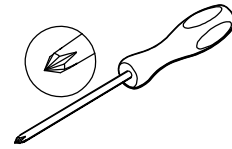

5

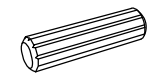

ADM x 10

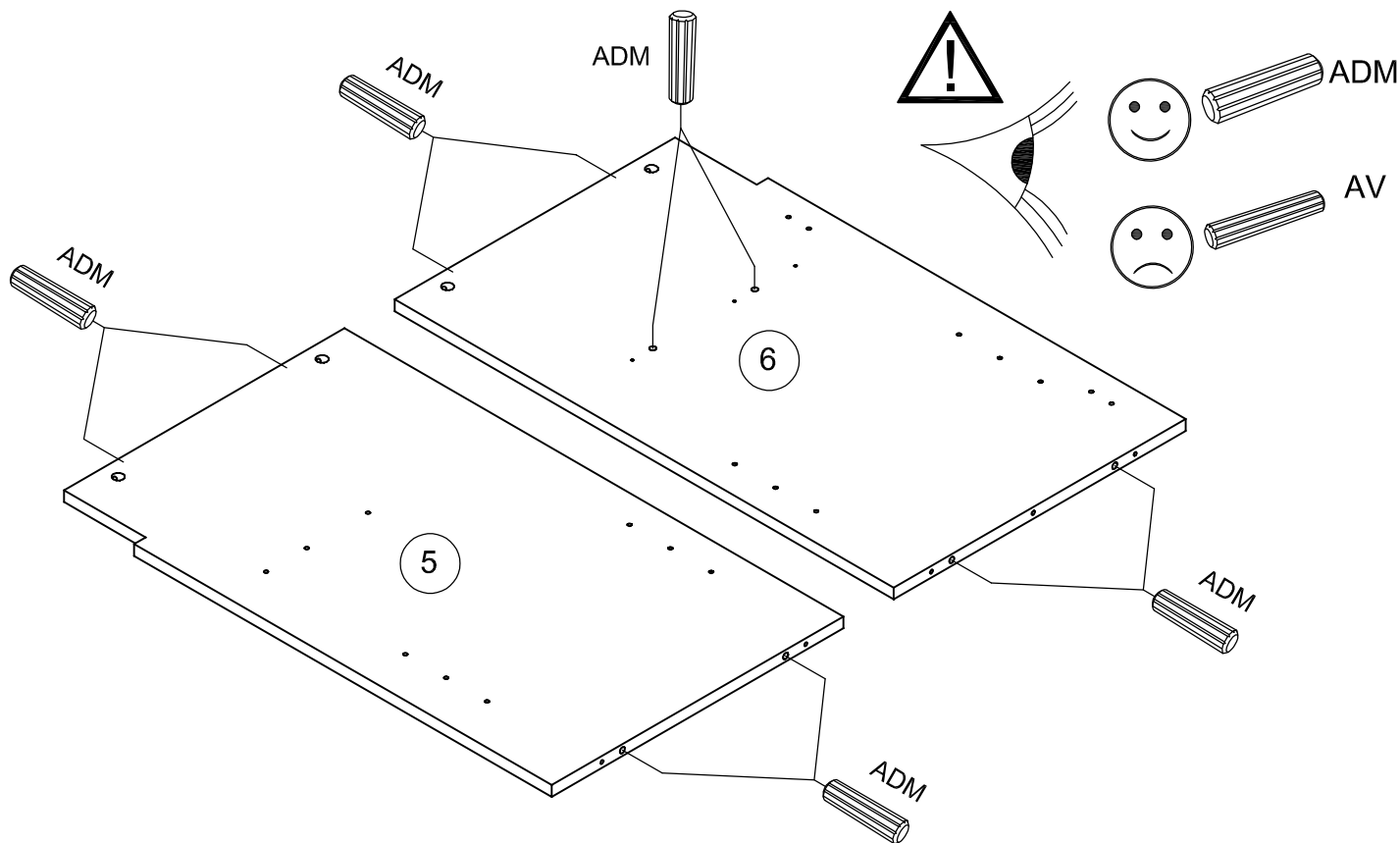

6

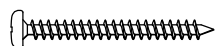

WI x 3

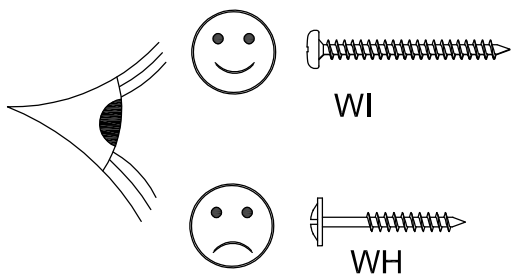
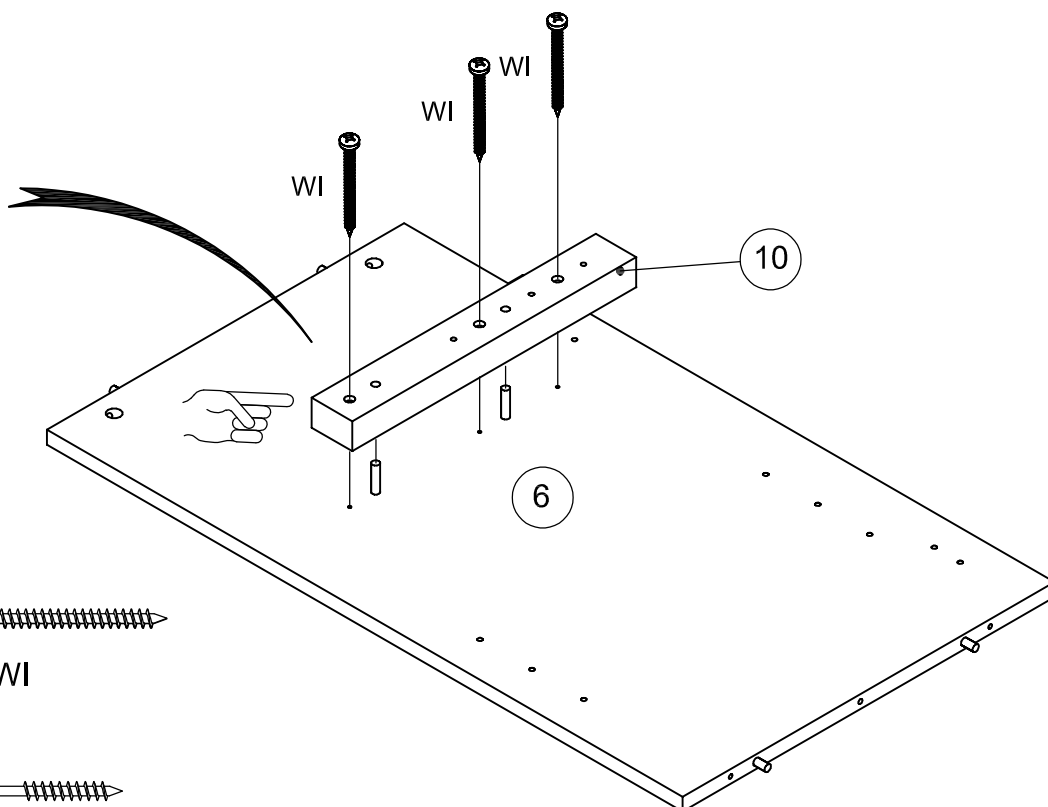
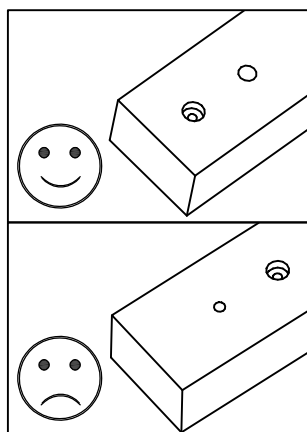
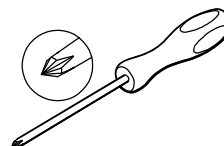

7

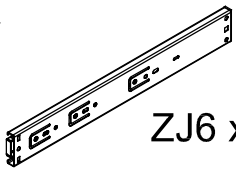

ZJ6 x 2

N1071_03

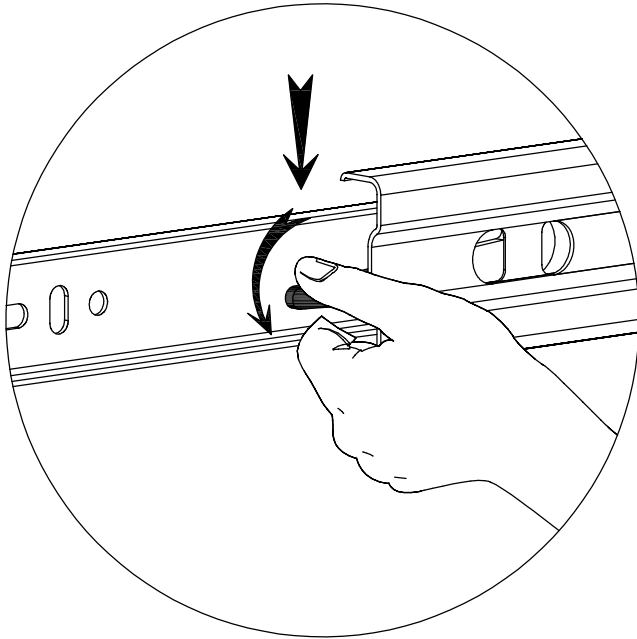

ZJ6 x 2

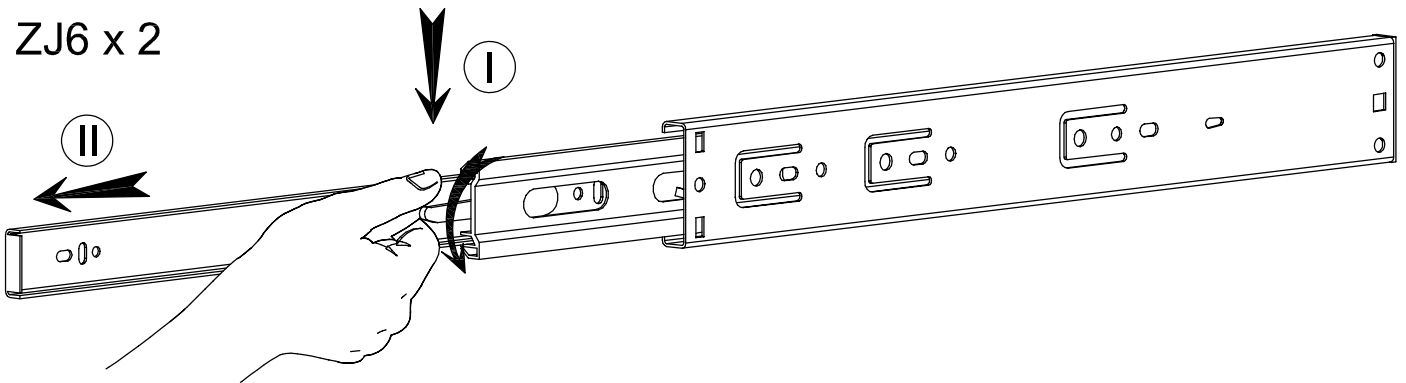

ZJ6 x 2

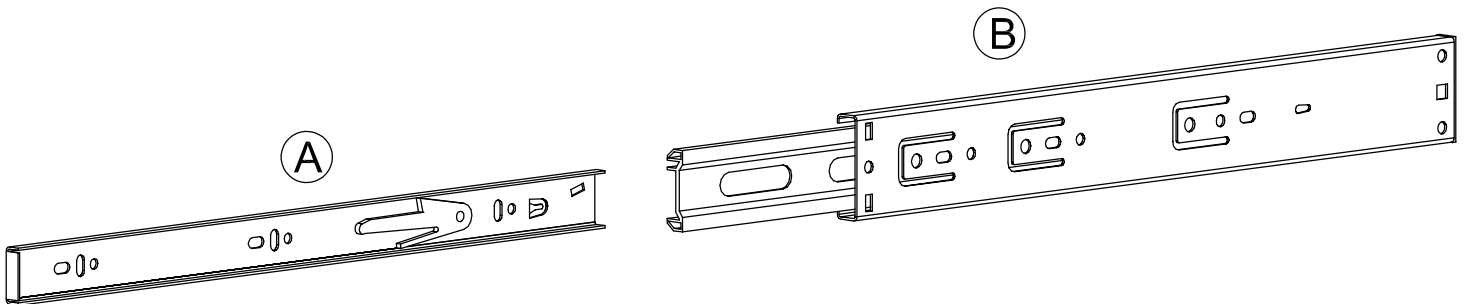

8

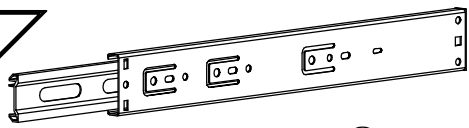

ZJ6B x 1

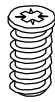

BWF X 3

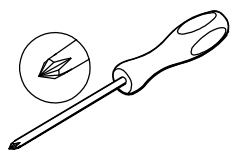

N1071_03

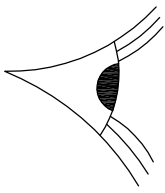

BWF



VB

BWF



ZJ6B

6

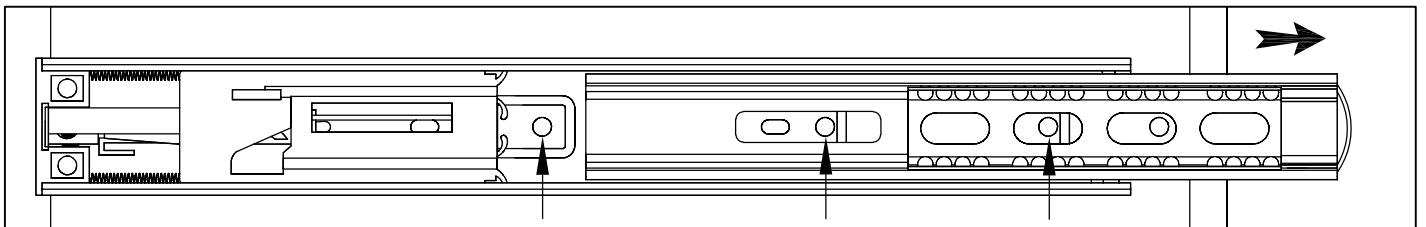
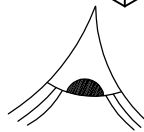

BWF

BWF

BWF

9

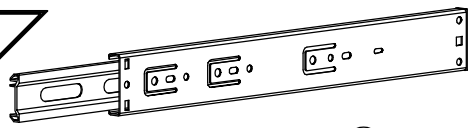

ZJ6(B) x 1



BWF X 3

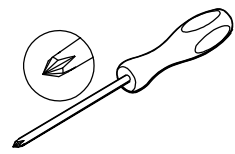

N1071_03

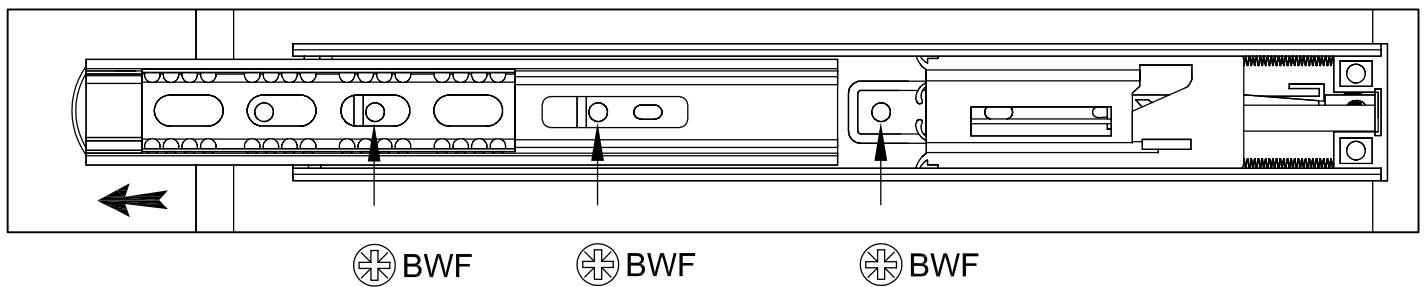
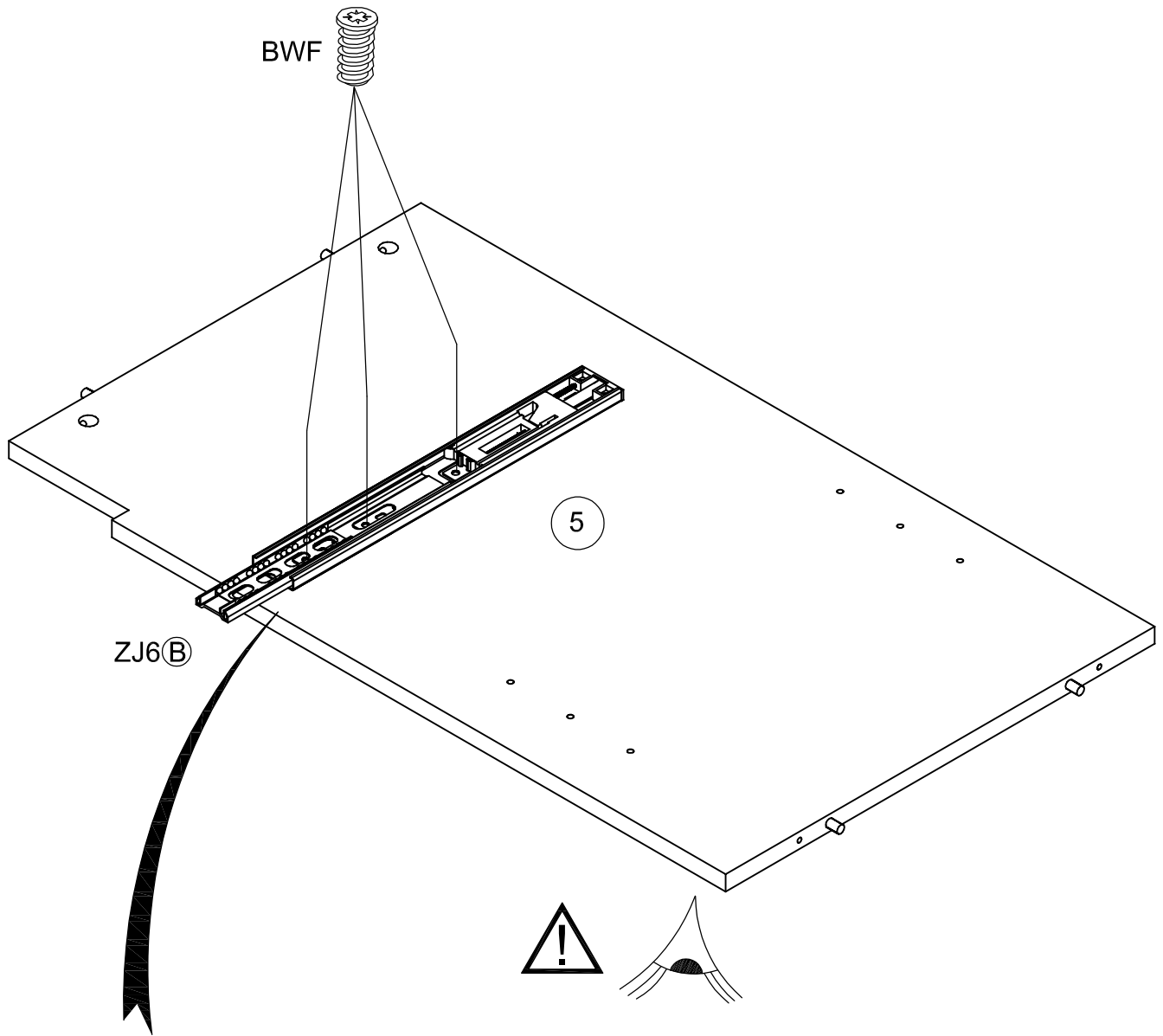

10

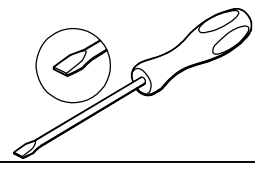

N1071_03

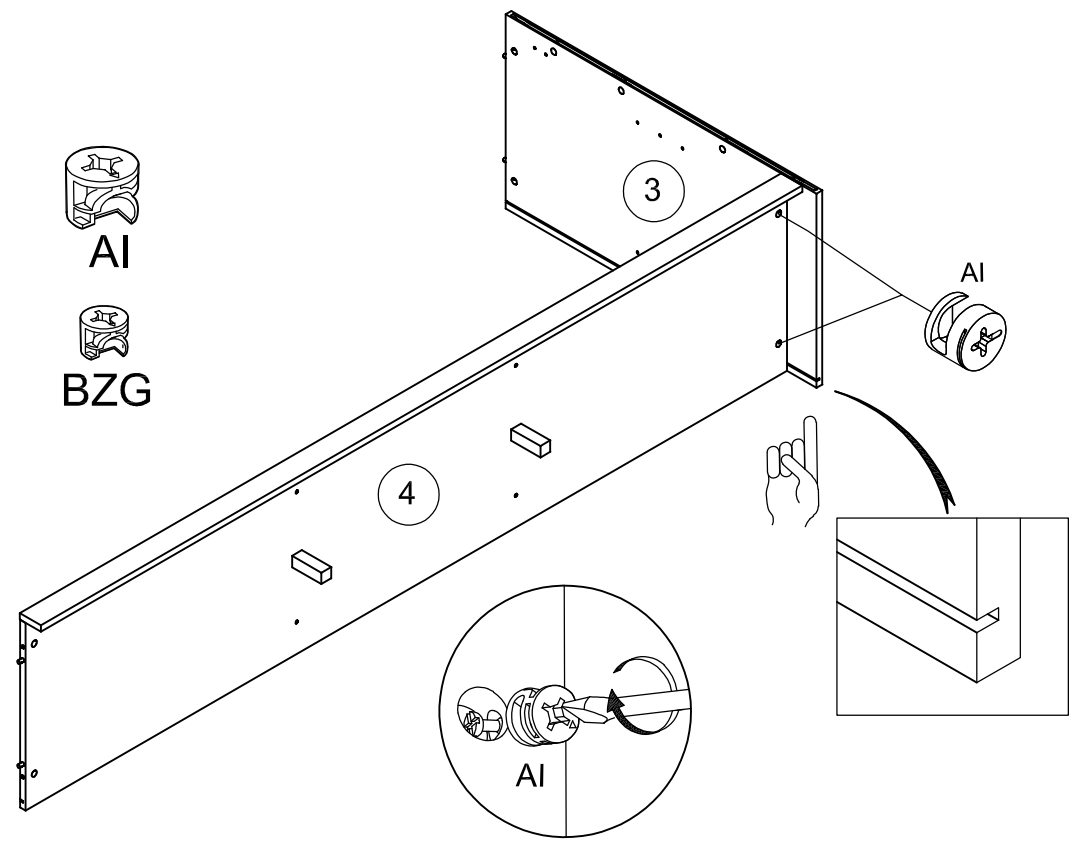
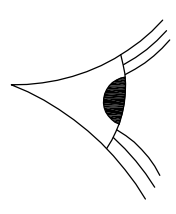
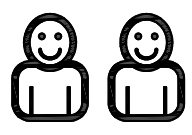

11

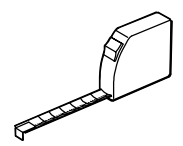
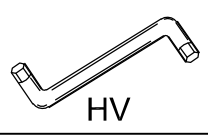
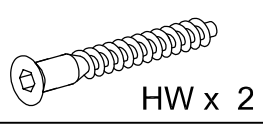

~mm

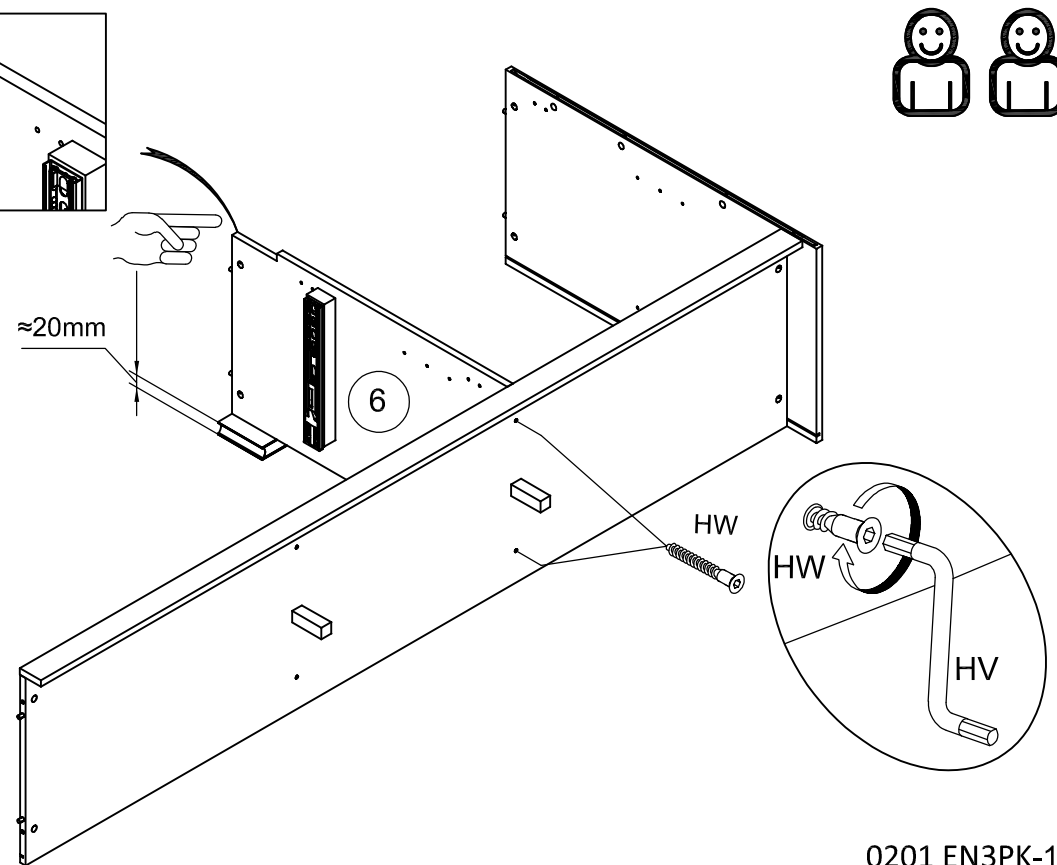
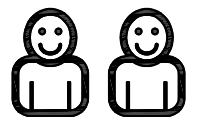
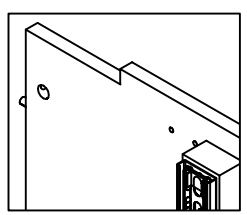

12

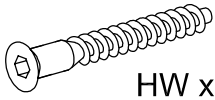

HW x 2

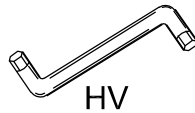

HV

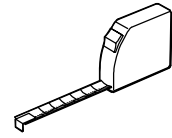

N1071_03
~mm

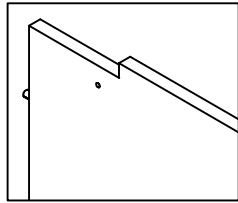

≈20mm

5

HW

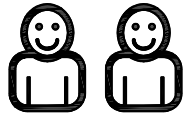
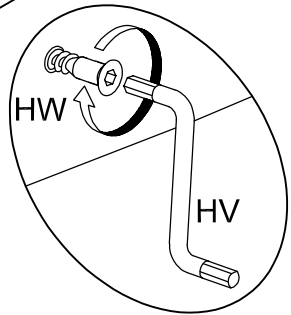

13

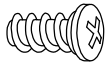

VB x 2

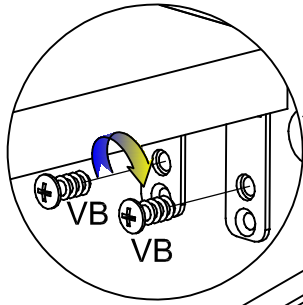
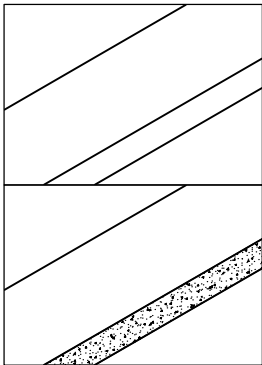
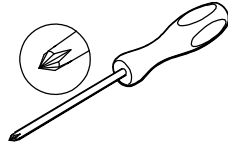

VB

14

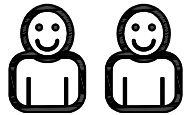

14



AI x2

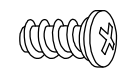

VB x2

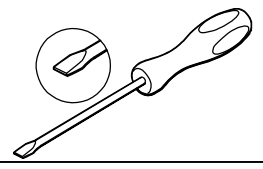
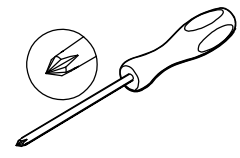

N1071_03

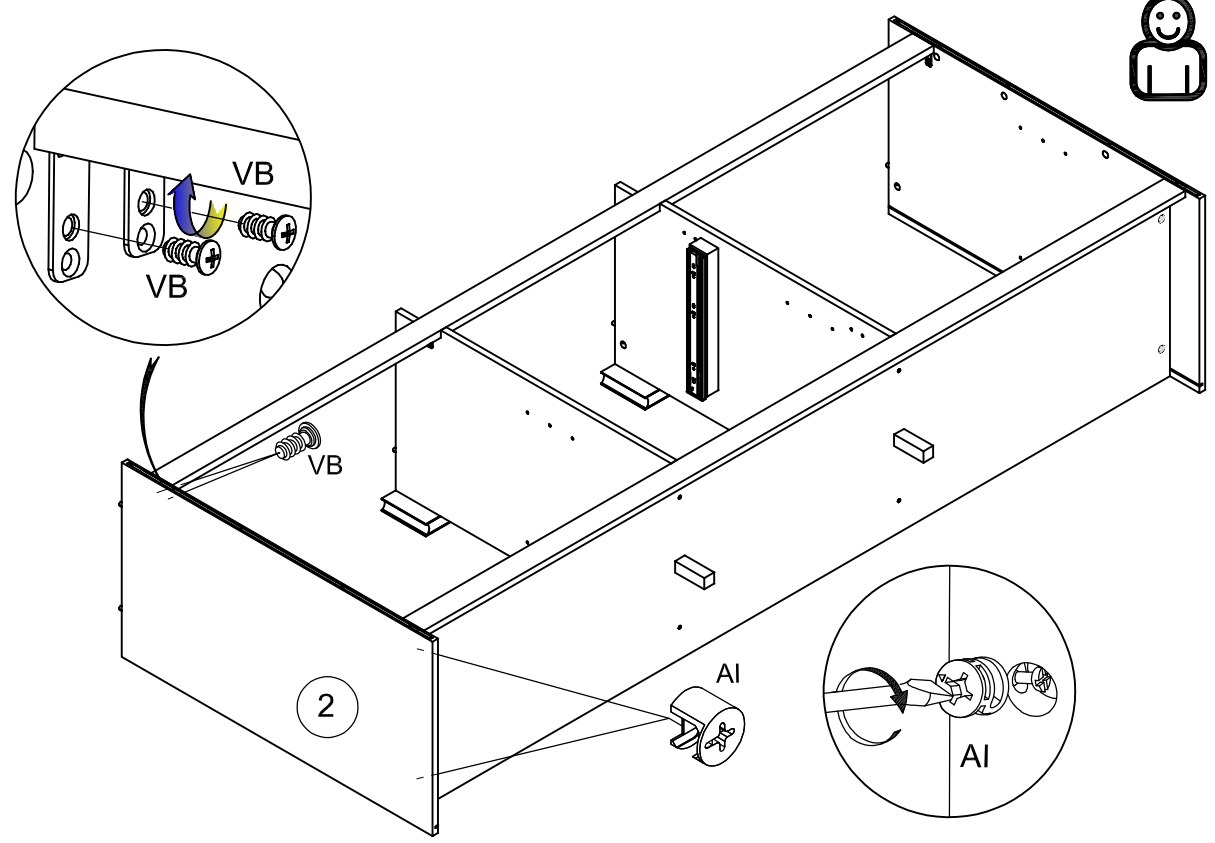
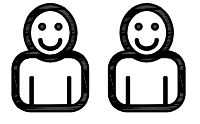

15

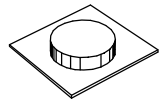

ZRV x 6

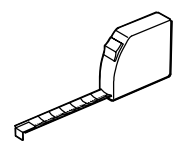

~mm

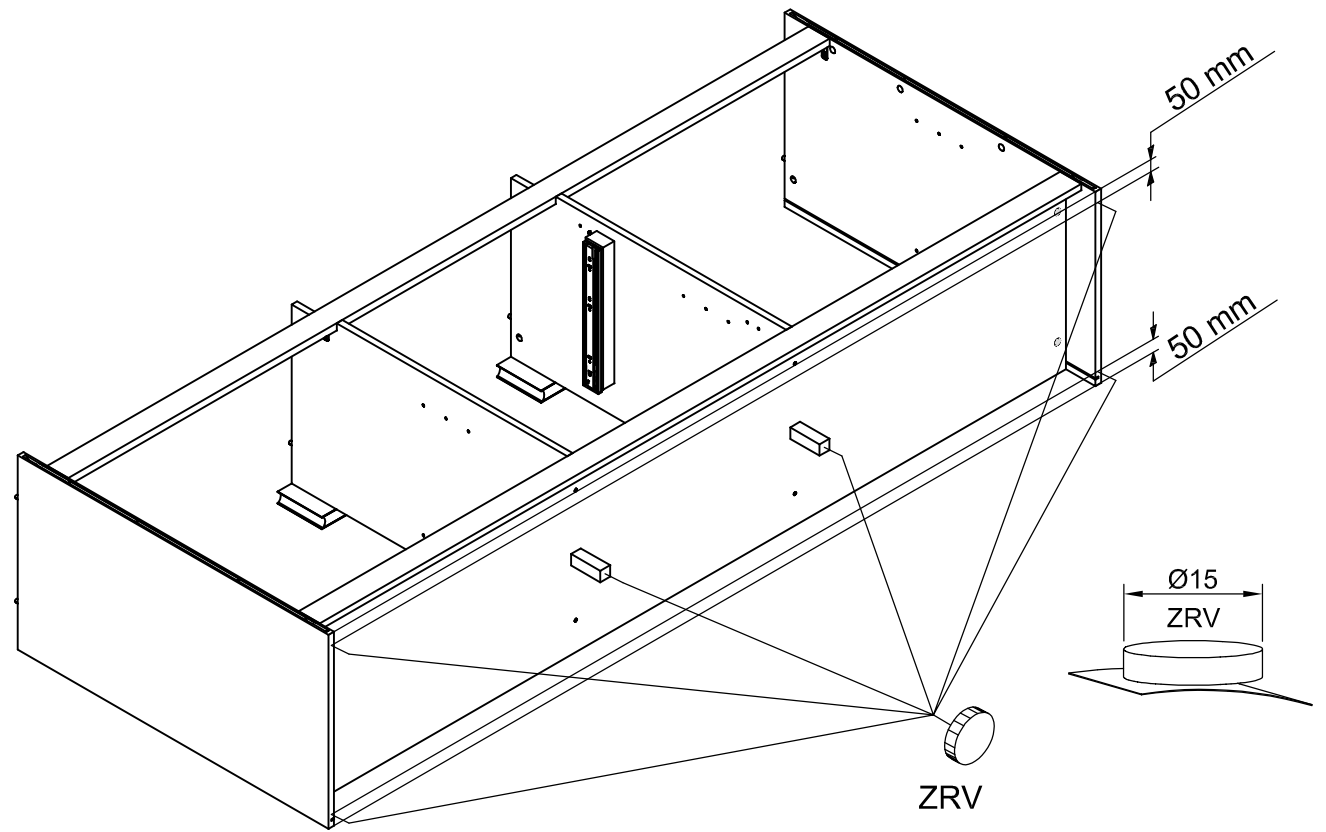

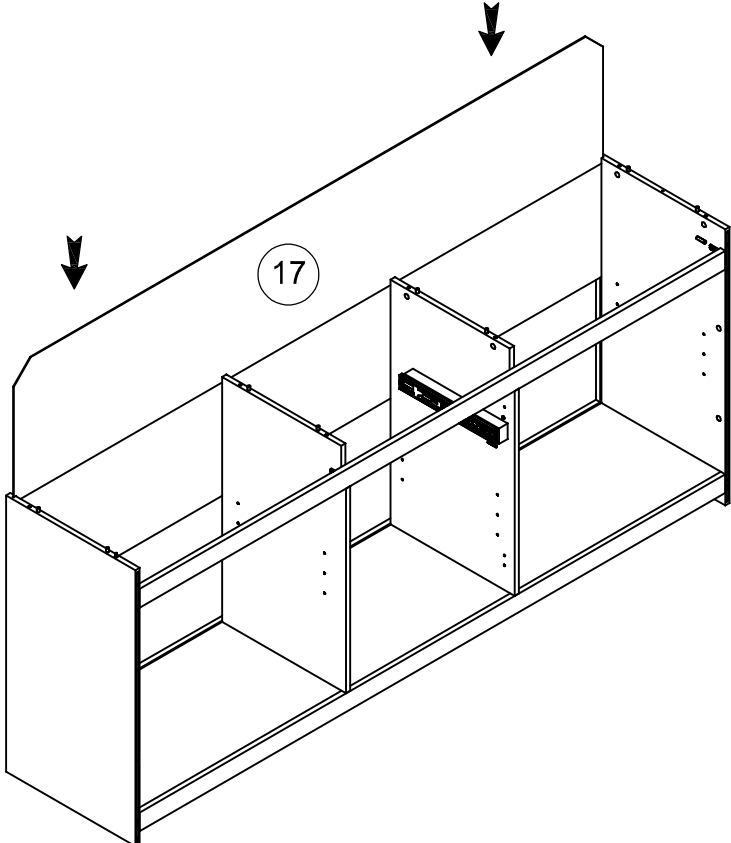
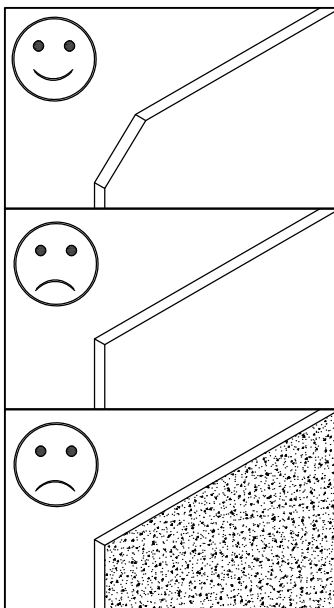
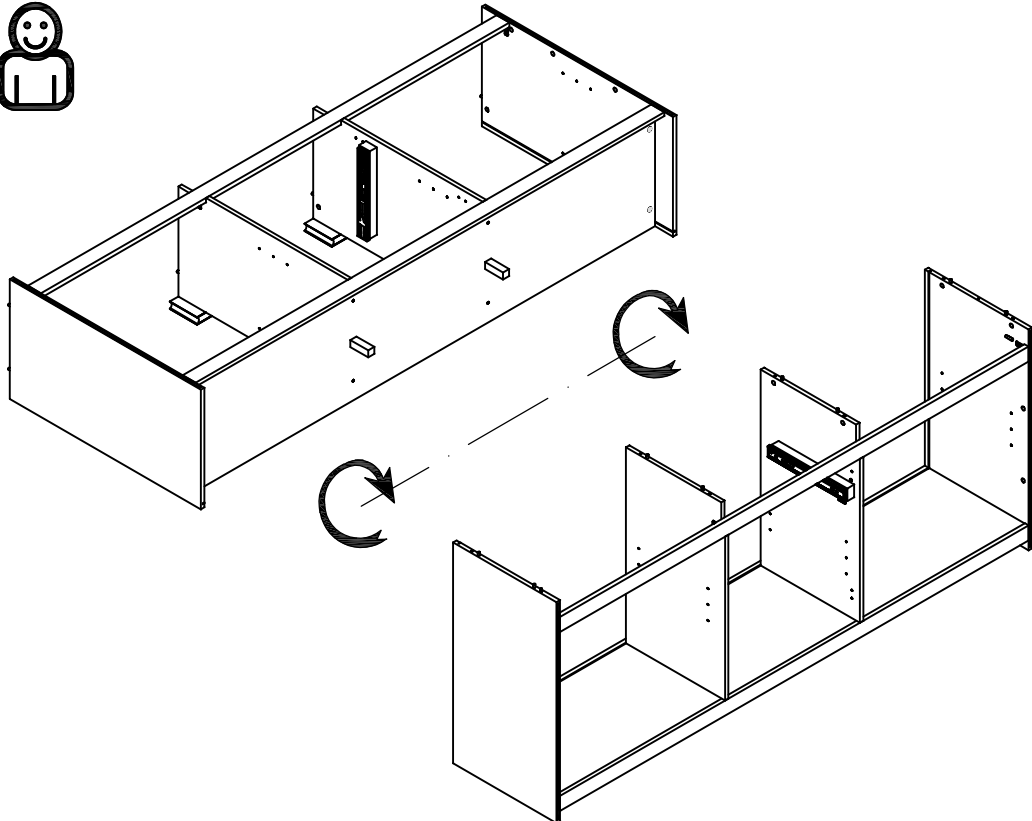
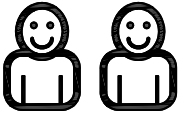

18

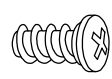

VB x 2

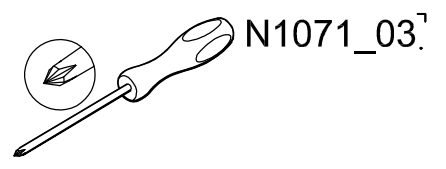

N1071_03

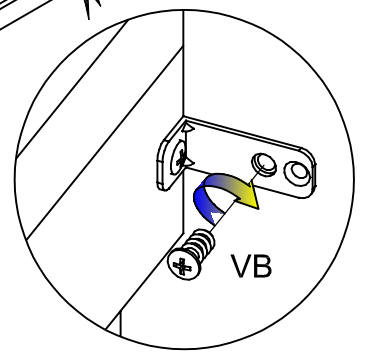
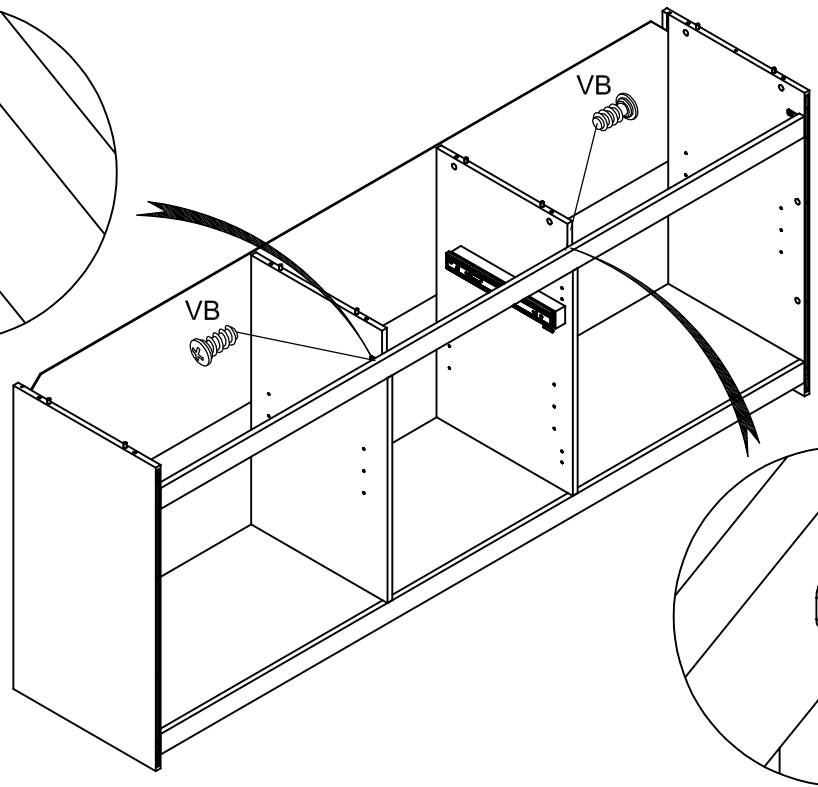
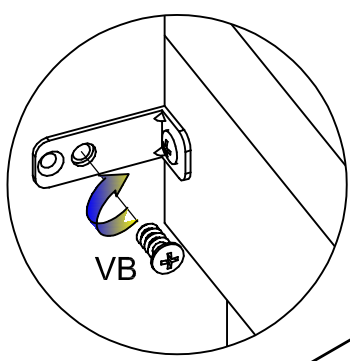

19

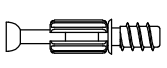

BWC x 8

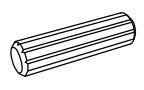

ADM x 7

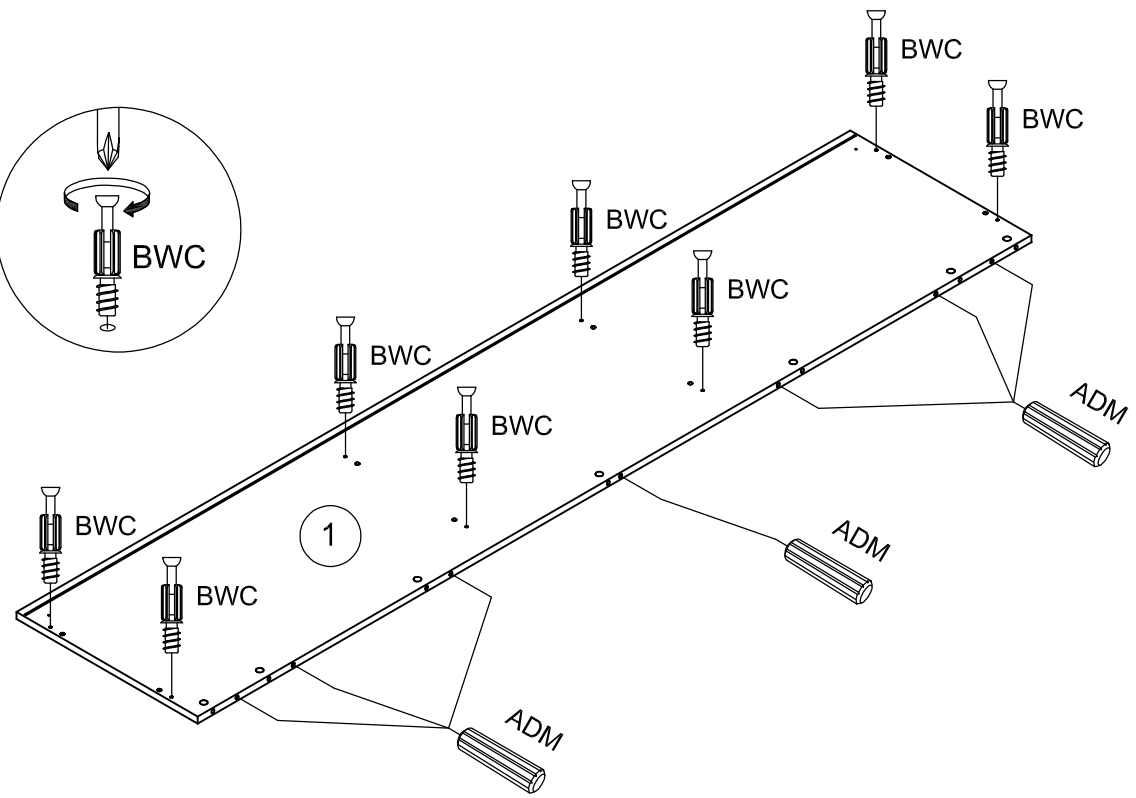
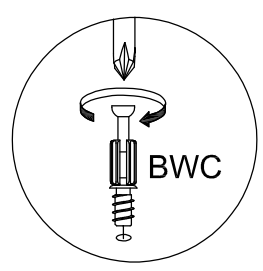
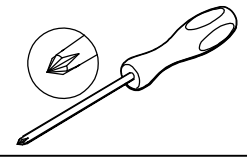

20

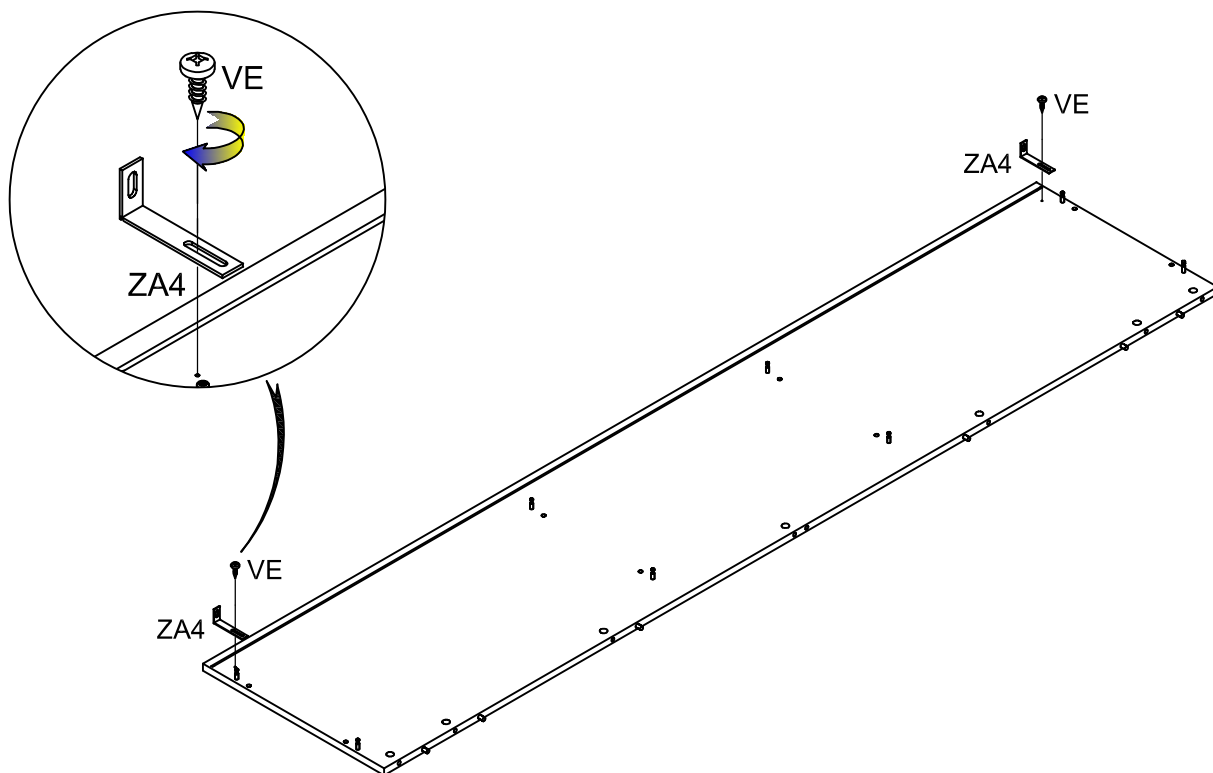
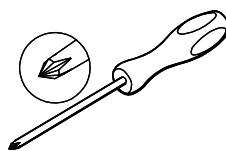
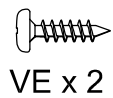
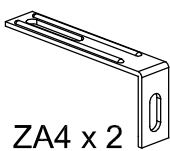

21

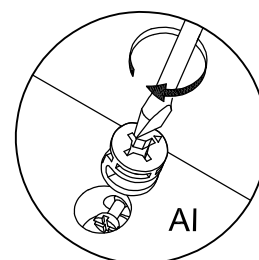
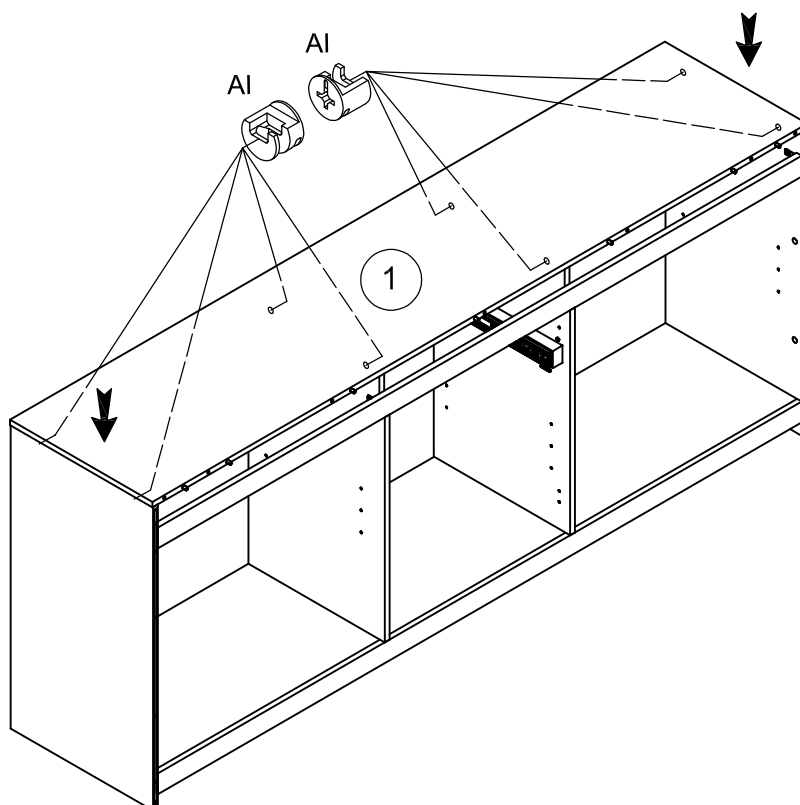
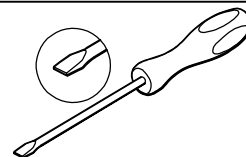

22

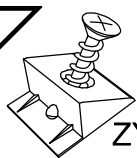

ZYY x 10

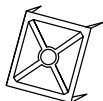

FA x 2



YBE x 2

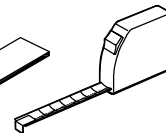
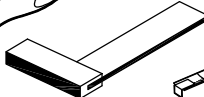
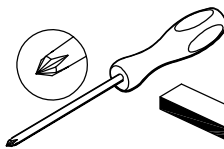

N1071_03
~mm

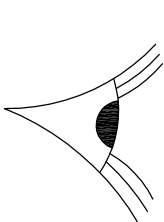

YBE

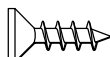

VG

1

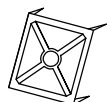

FA

2

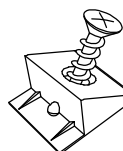

ZYY

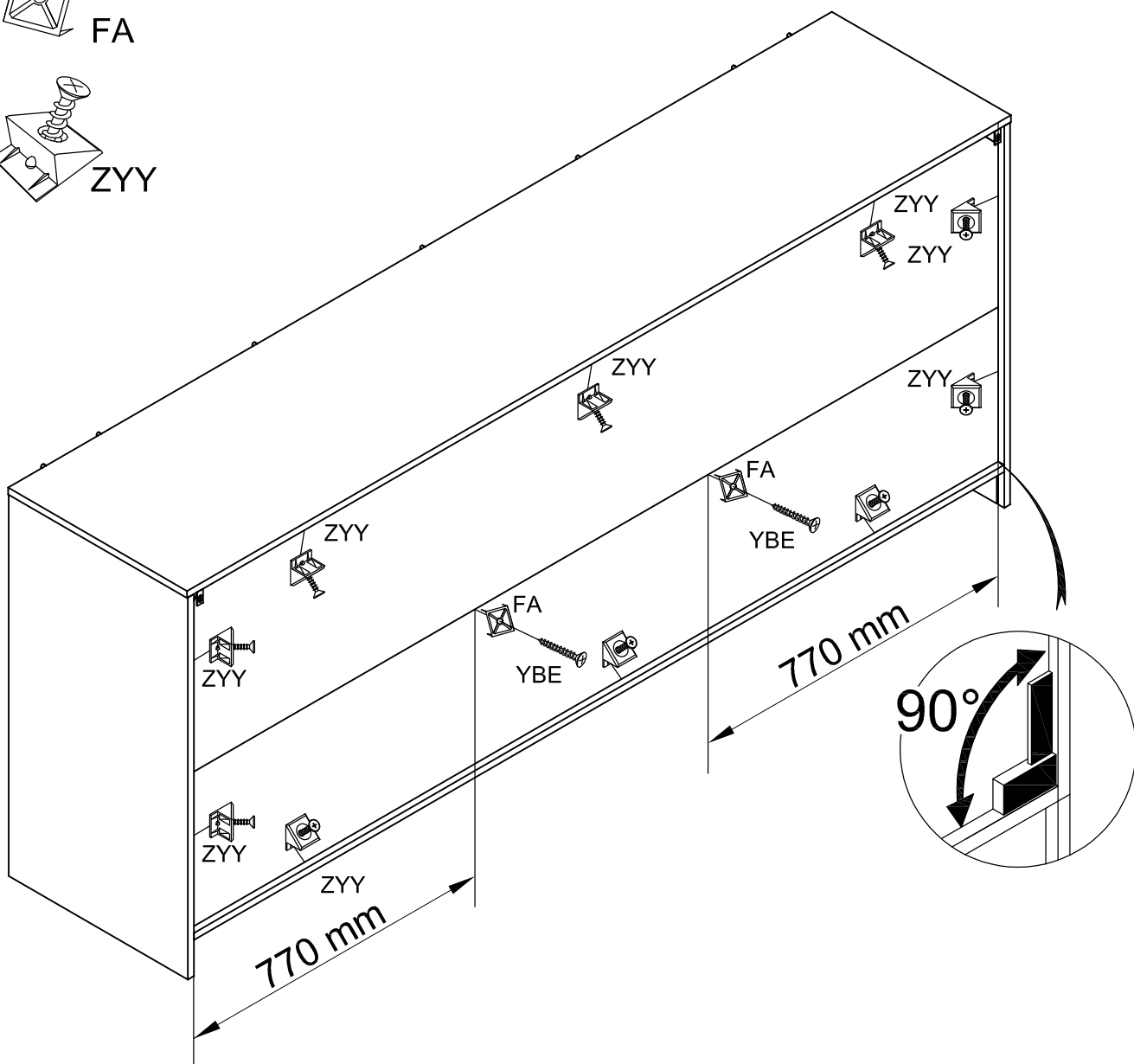

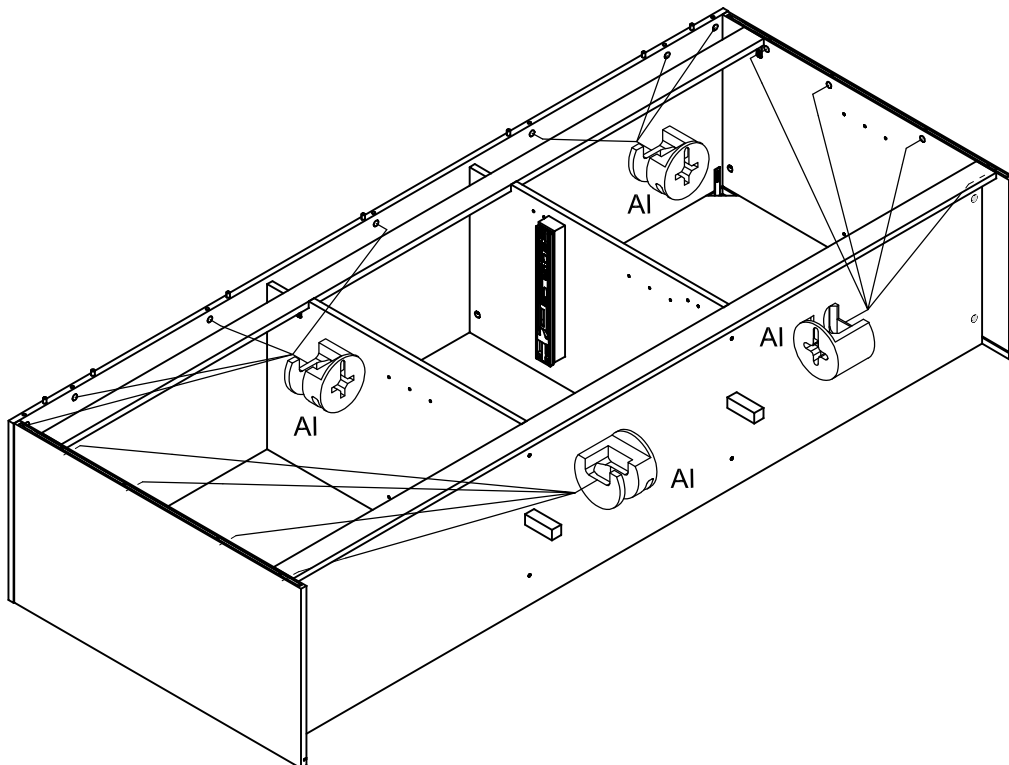
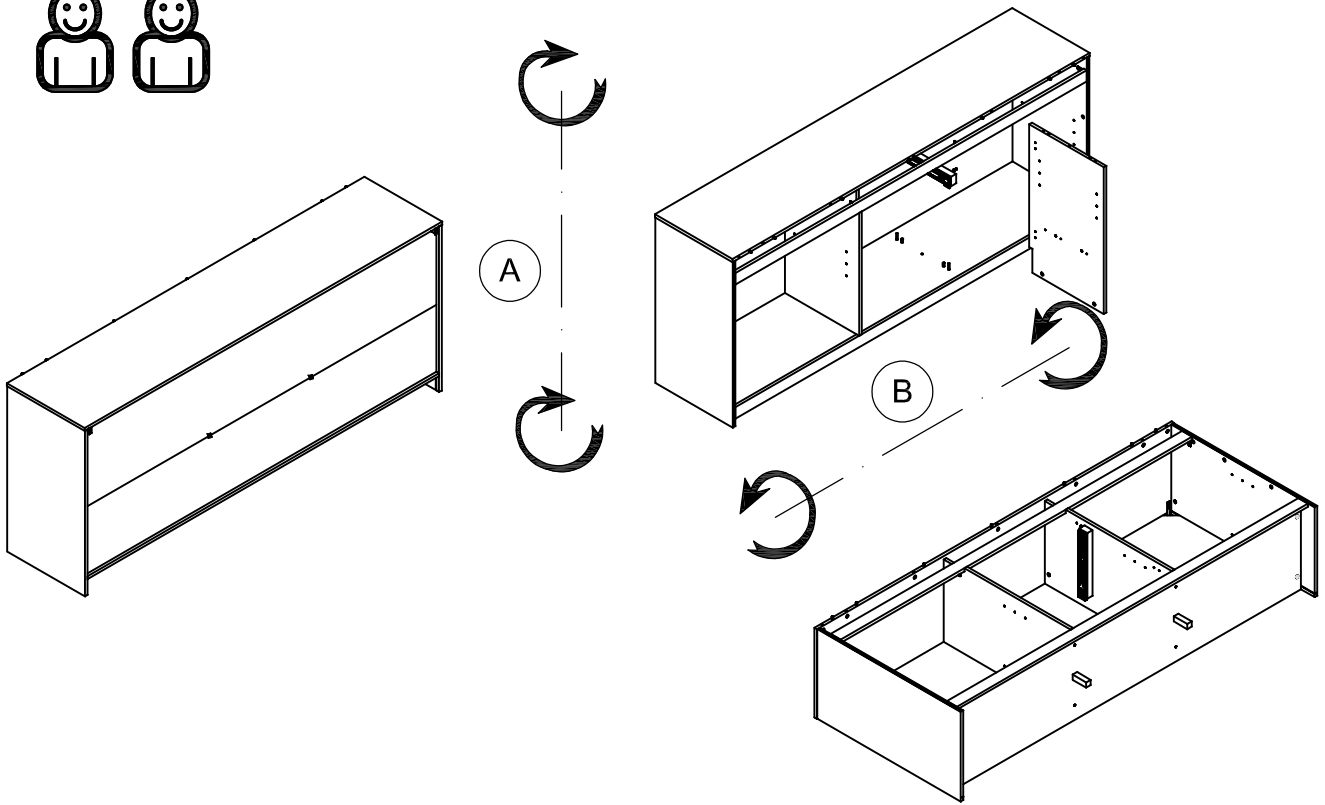
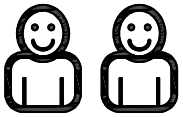

25

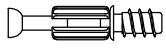

BWC x 17



ADM x 2



N1071_03

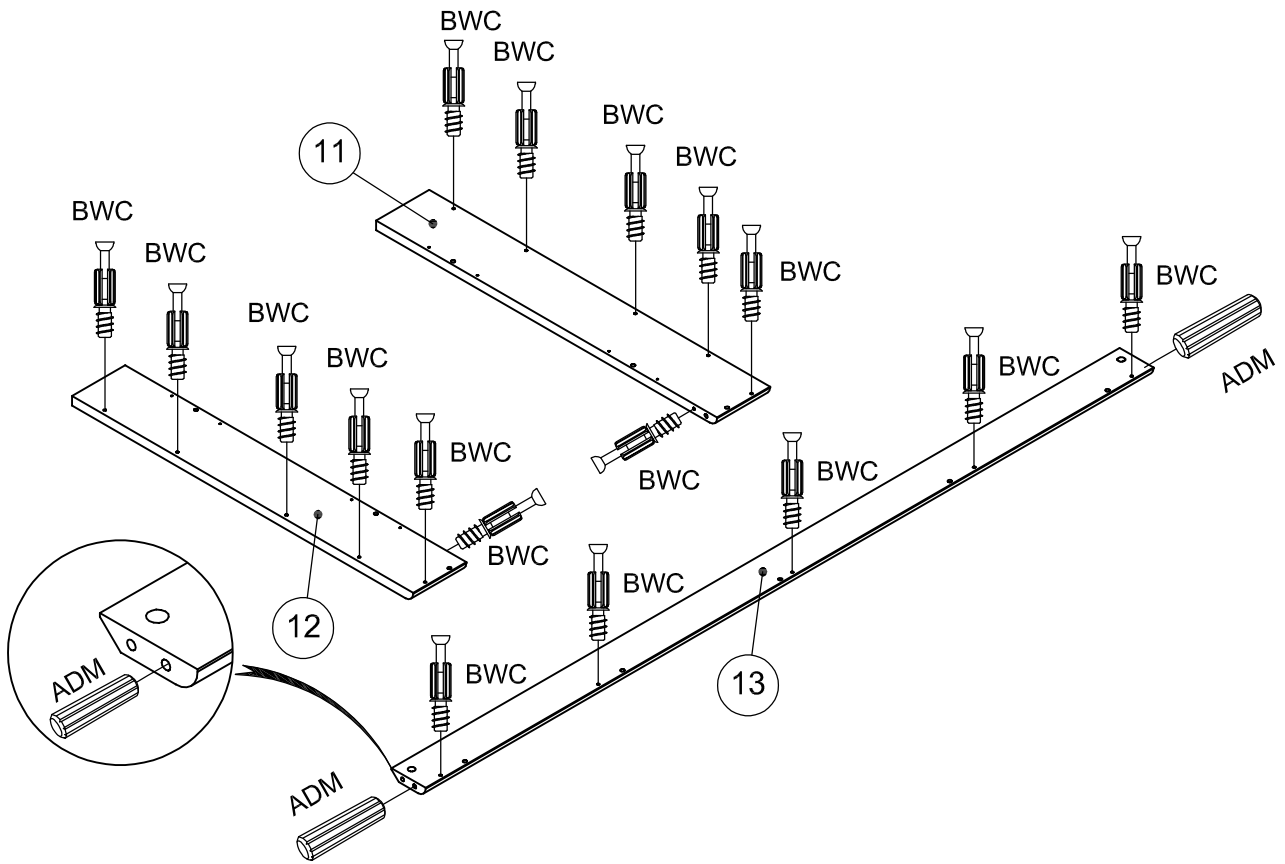

26



ADM x 4

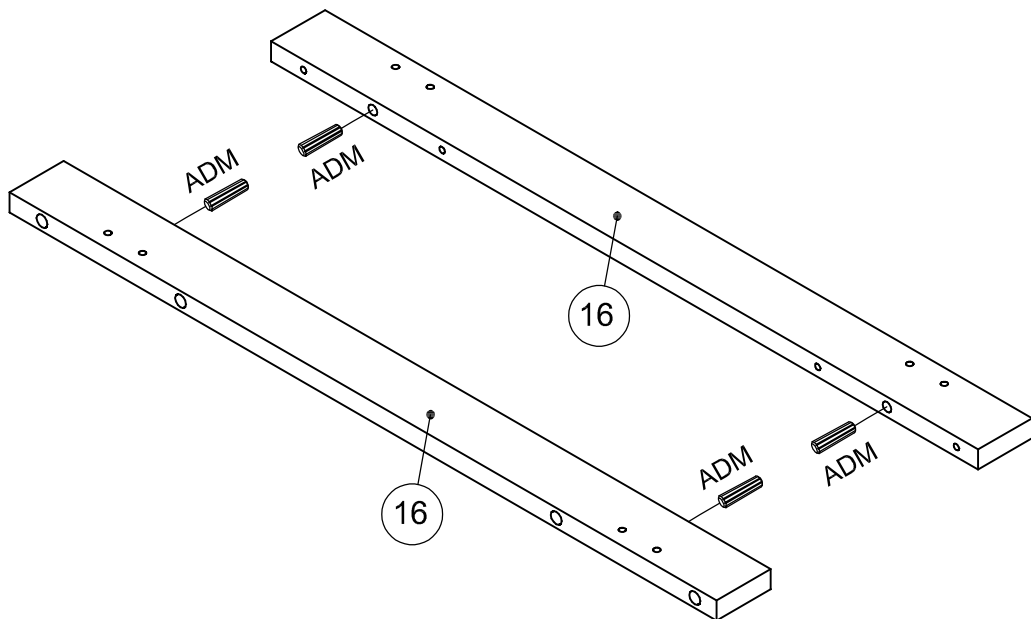

27

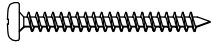

WI x 8

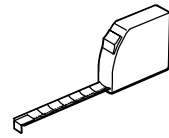
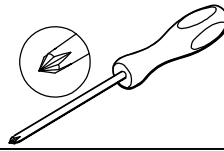

N1071_03

~mm

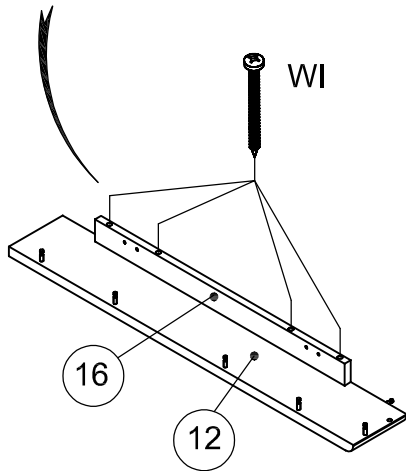
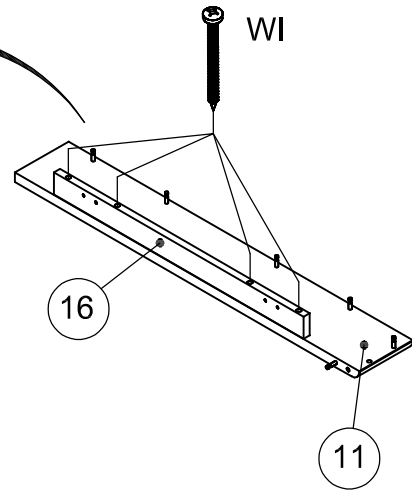
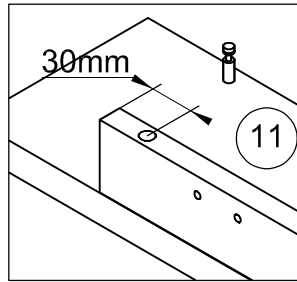
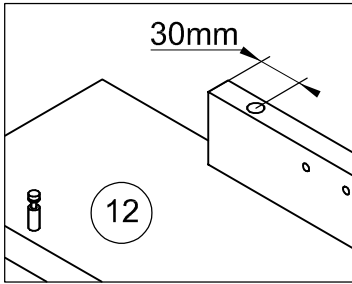

28



AI x 2

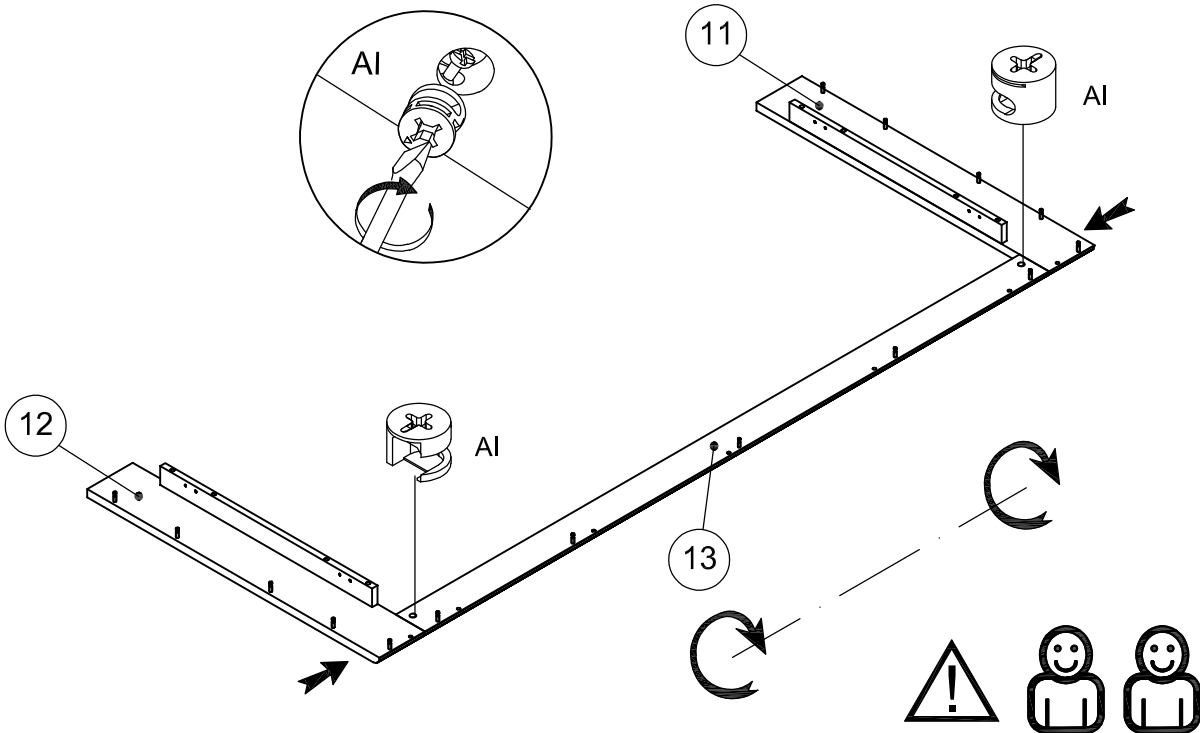
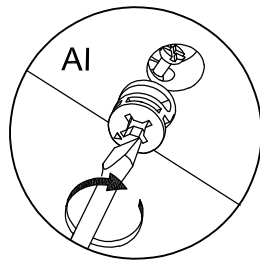
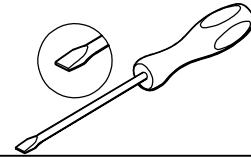

29

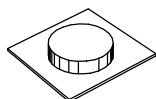

ZRV x 2

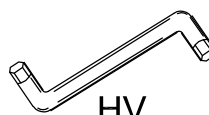

HV

N1071_03

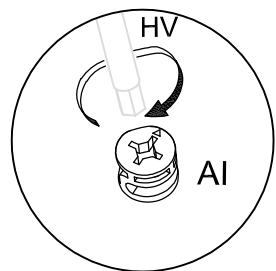

x15

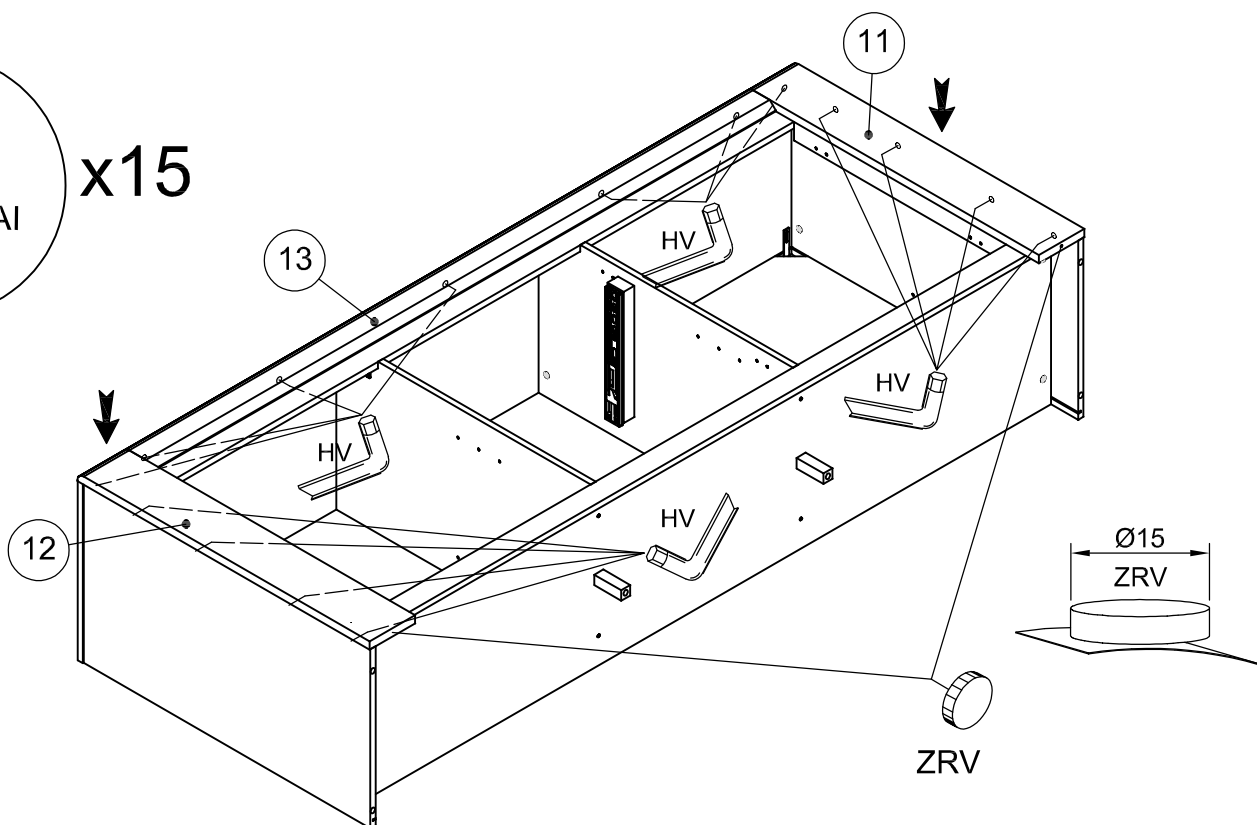

30

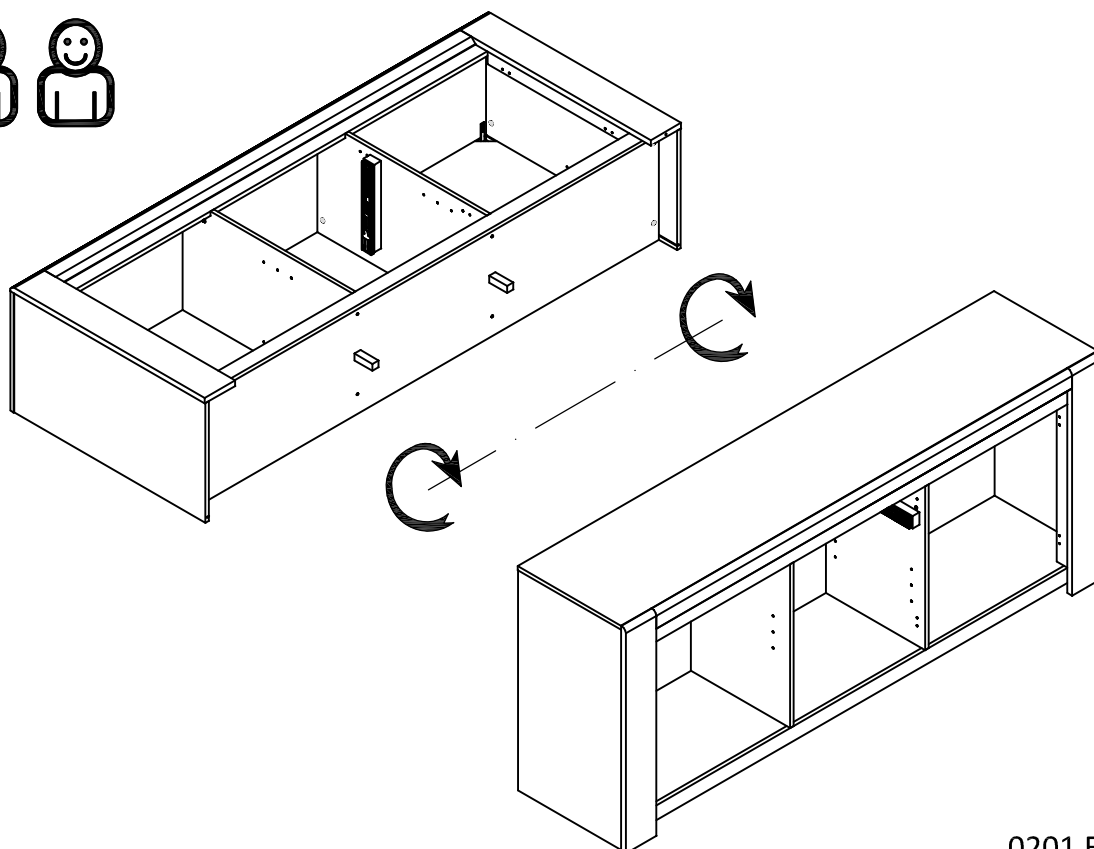
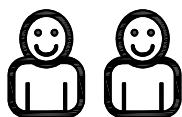

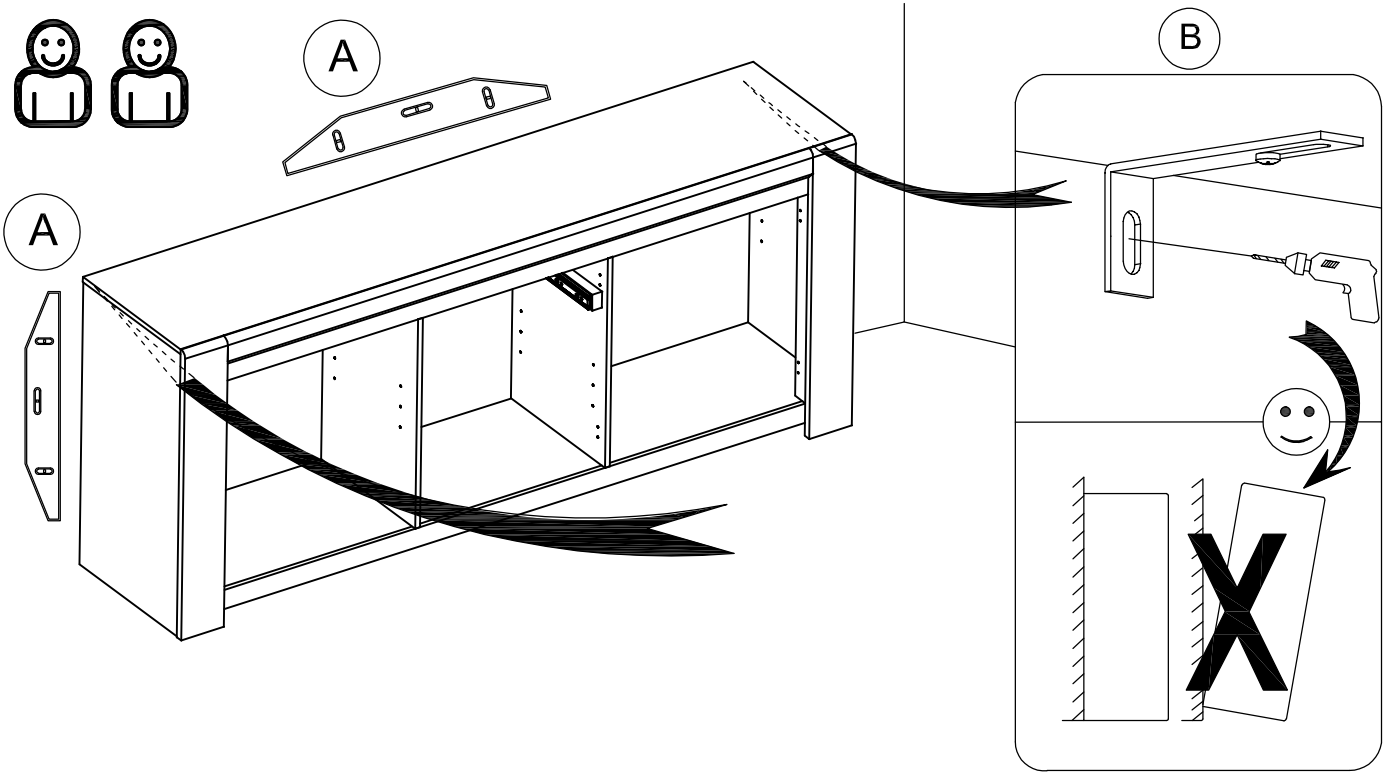
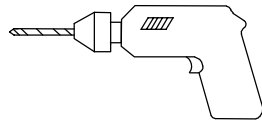

IMPORTANT: Pour éviter le basculement accidentel du meuble, la fixation du meuble au mur est obligatoire.
La visserie nécessaire pour la jonction mur/meuble, dépendante de la nature du mur, n'est pas fournie.
En cas de doute, consulter un spécialiste

English

IMPORTANT: To avoid the accidental tip-over of the furniture, the fixing of the furniture on the wall is mandatory.
The needed hardware for the junction wall/furniture, depending of the nature of the wall, is not provided.
If any doubt, consult a specialist.

Spanish

IMPORTANTE: Para evitar el vuelco accidental de los muebles, es obligatorio fijarlos en la pared.
El tipo de tornillos necesarios para fijar el mueble a la pared, dependen del material de la pared, no se suministran.
En caso de duda, consulte a un especialista.

Portuguese

IMPORTANTE: Para evitar a queda accidental de móveis, é obrigatorio fixá-los na parede.
O tipo de parafusos para a fixação de mobiliário na parede, depende do material de parede e não são fornecidos.
Em caso de dúvida, consulte um especialista.

Italian

IMPORTANTE: Per evitare il ribaltamento accidentale del mobile è obbligatorio il fissaggio a muro.
I tasselli necessari per il collegamento mobile\muro, dipendenti dal tipo di muro, non sono provvisti.
Consultare uno specialista in caso di dubbi

Croatian

VAŽNO: Kako bi se izbjeglo slučajno prevrtanje, namještaj je potrebno pričvrstiti na (uza) zid.
Različite vrste zidova zahtijevaju upotrebu različitih vrsta vijaka i tipli. Uvijek koristiti one koji su prikladni za vrstu zidova u domu. Vijci i tiple prodaju se zasebno.
U slučaju bilo kakvih sumnji, obratite se stručnjaku.

German

WICHTIG : Um ein versehentliches Kippen des Möbels zu vermeiden, ist die Befestigung an der Wand zwingend vorgeschrieben.
Die benötigten Schrauben zur Wandbefestigung, welche von der Beschaffenheit der Mauer abhängen, sind nicht in der Lieferung enthalten.
Wenden Sie sich bitte bei Zweifel an einen Spezialisten.

32

BWD x 12

N1071_03

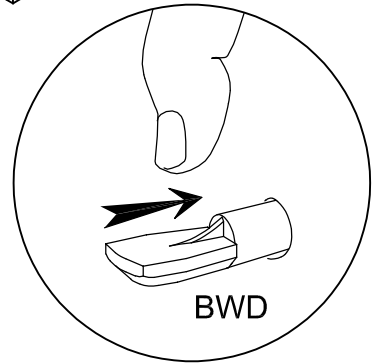
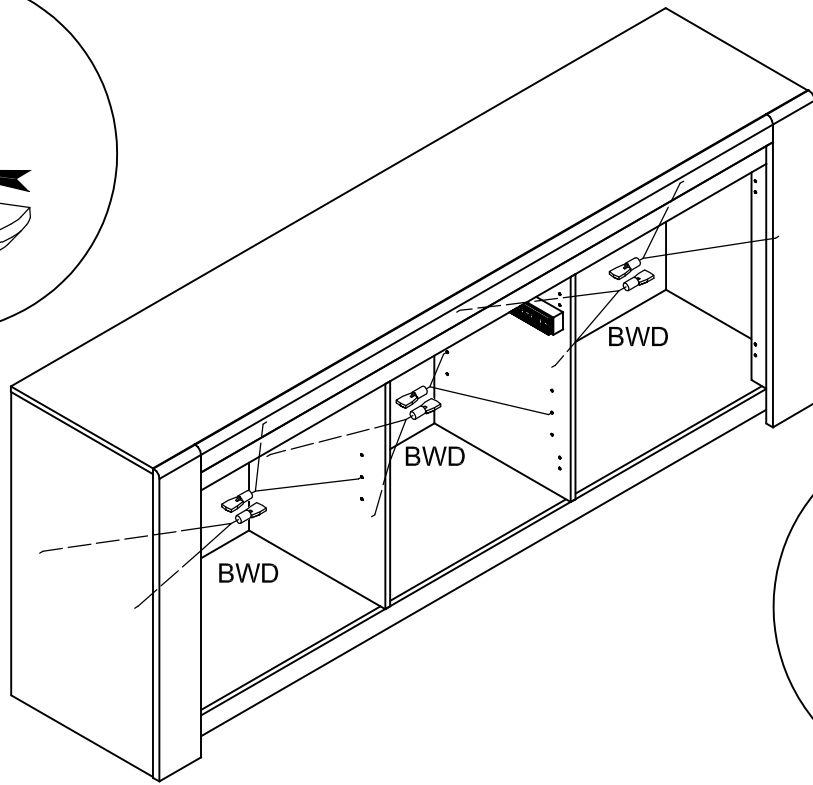
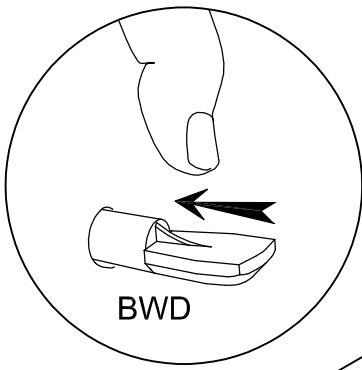

33

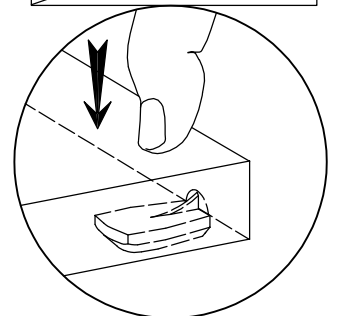
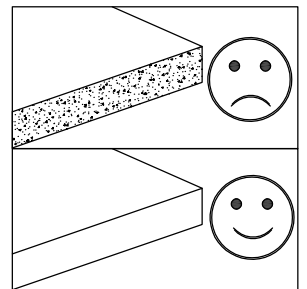
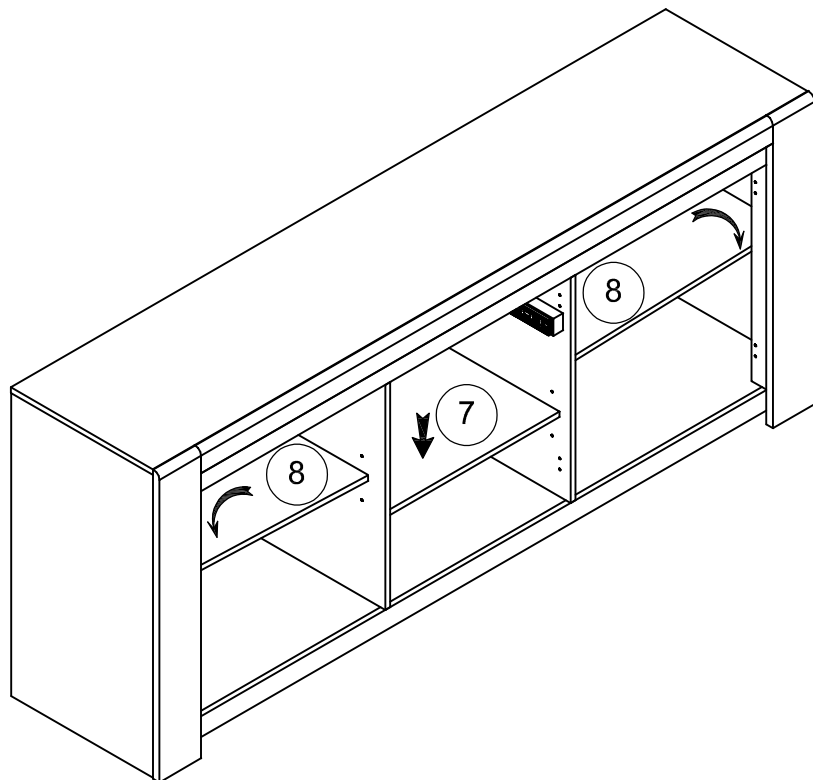

34

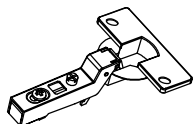

YMF x 4

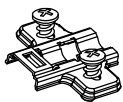

YME x 4



VI x 8



AQO x 4

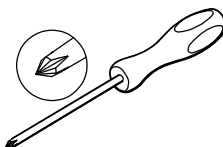

N1071_03

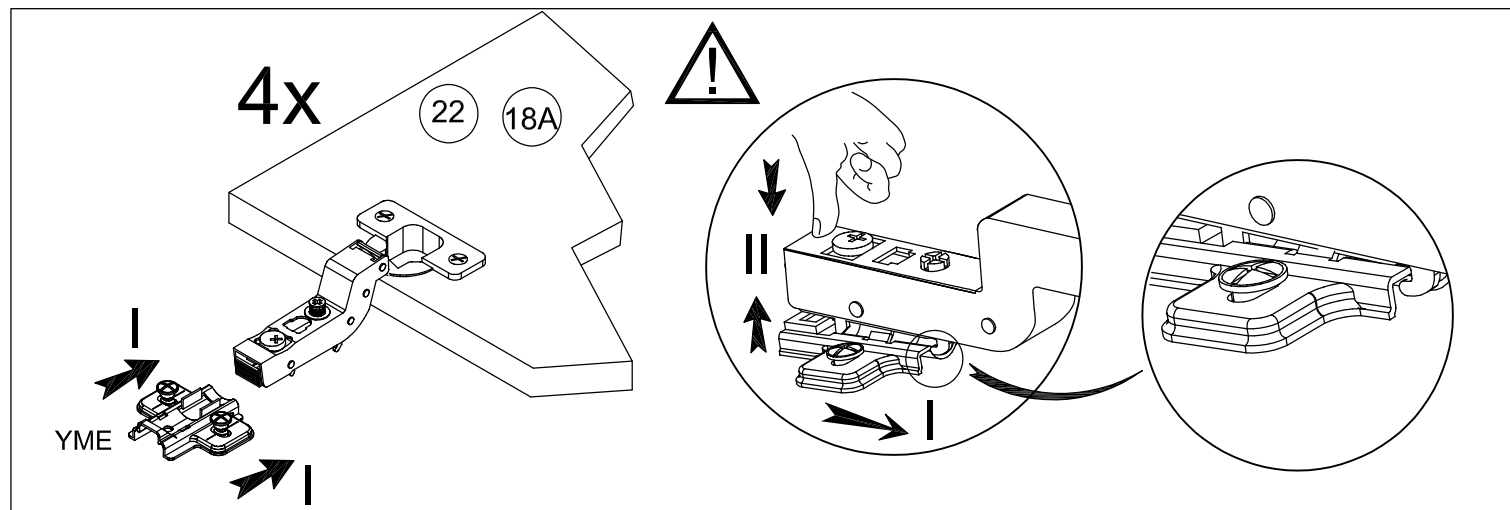
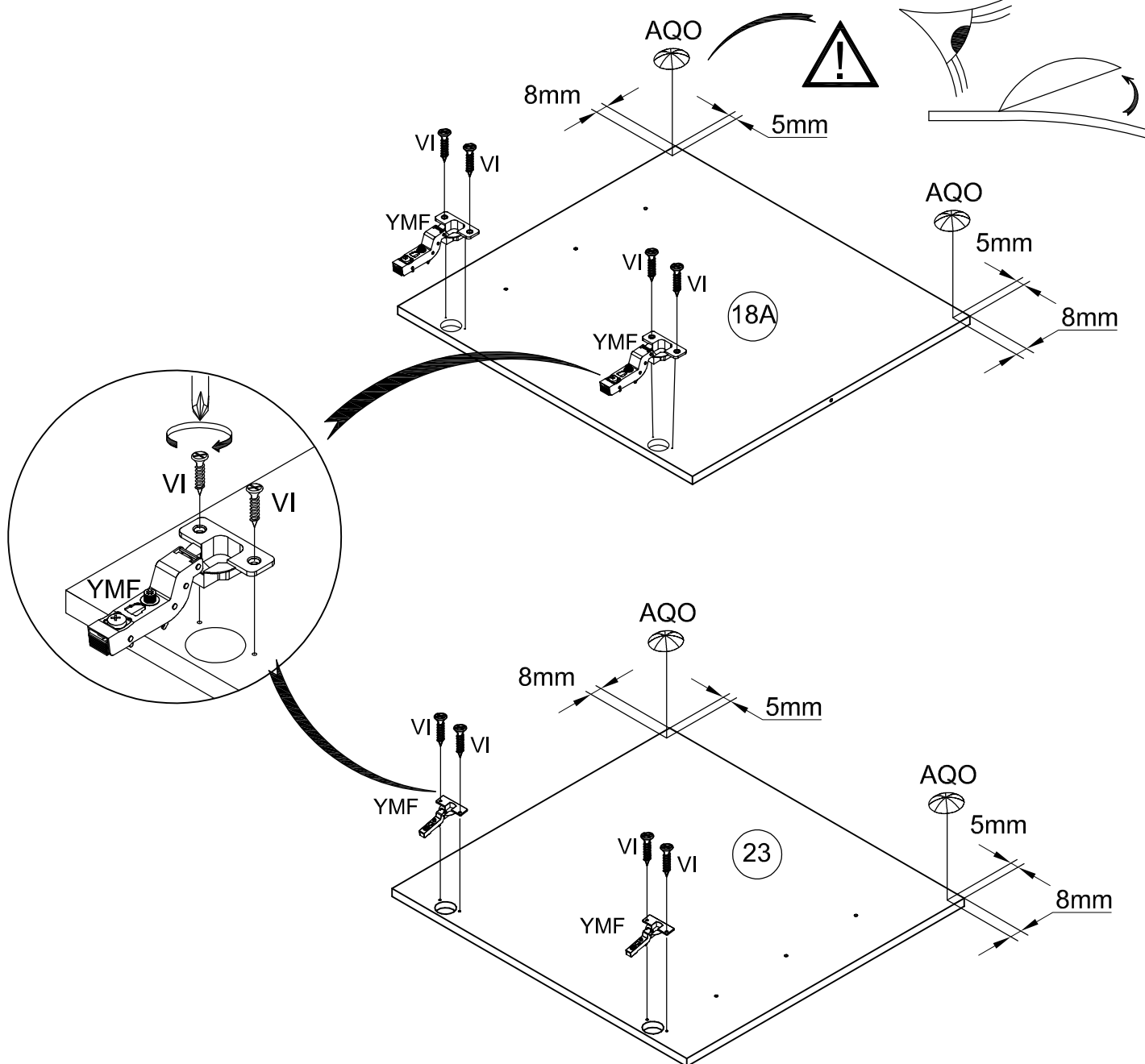

35

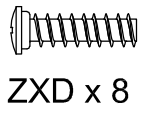

ZXD x 8

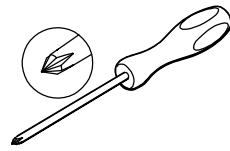

N1071_03

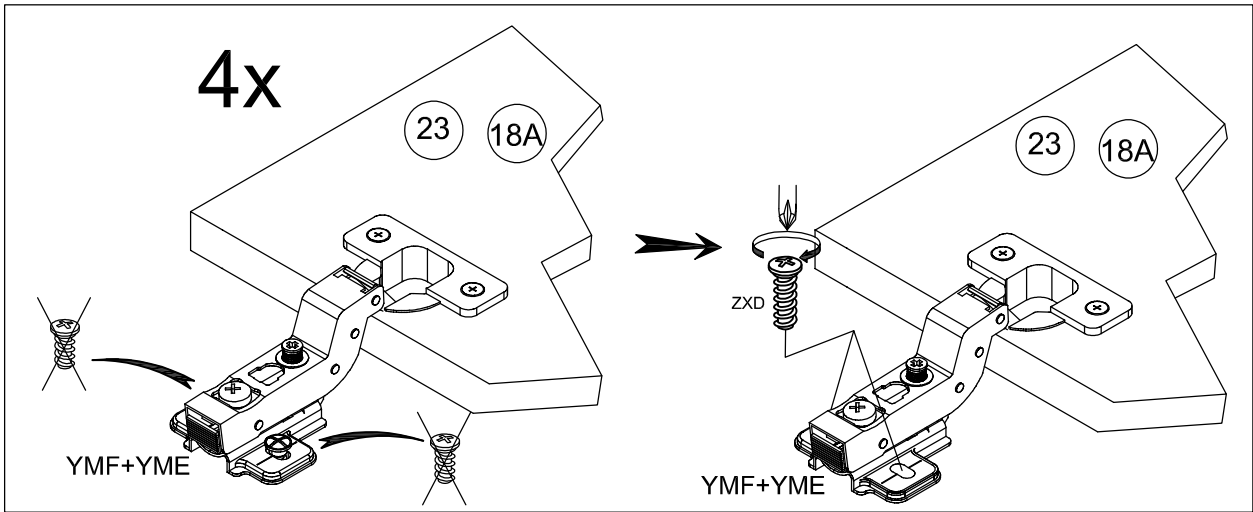

36

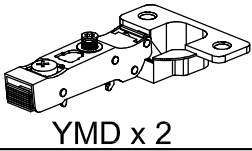

YMD x 2

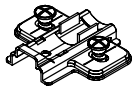

YME x 2



VI x 4



AQO x 2

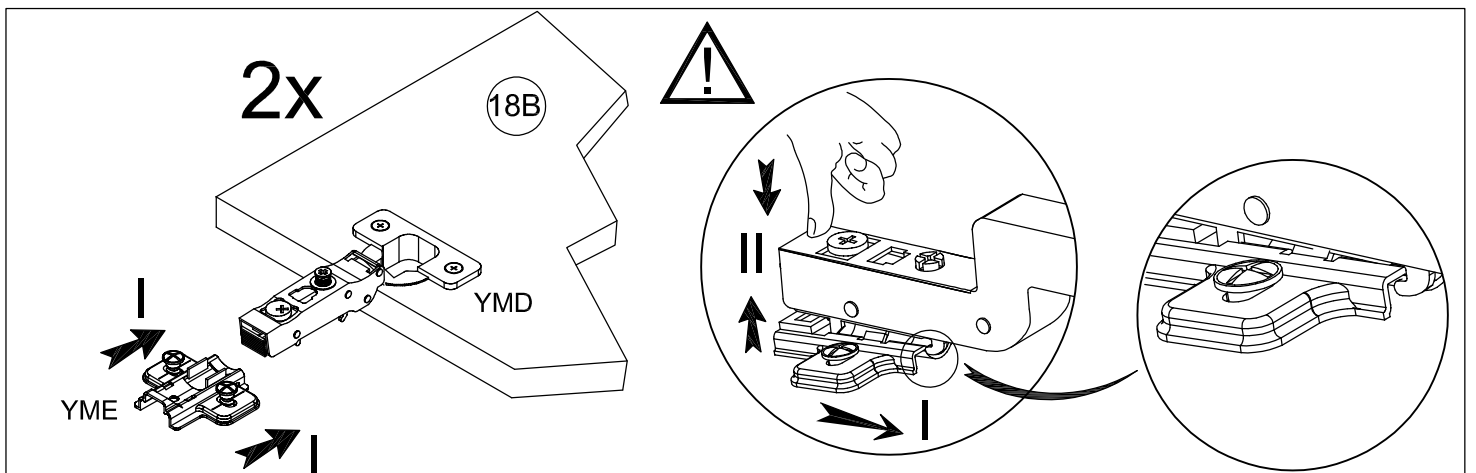
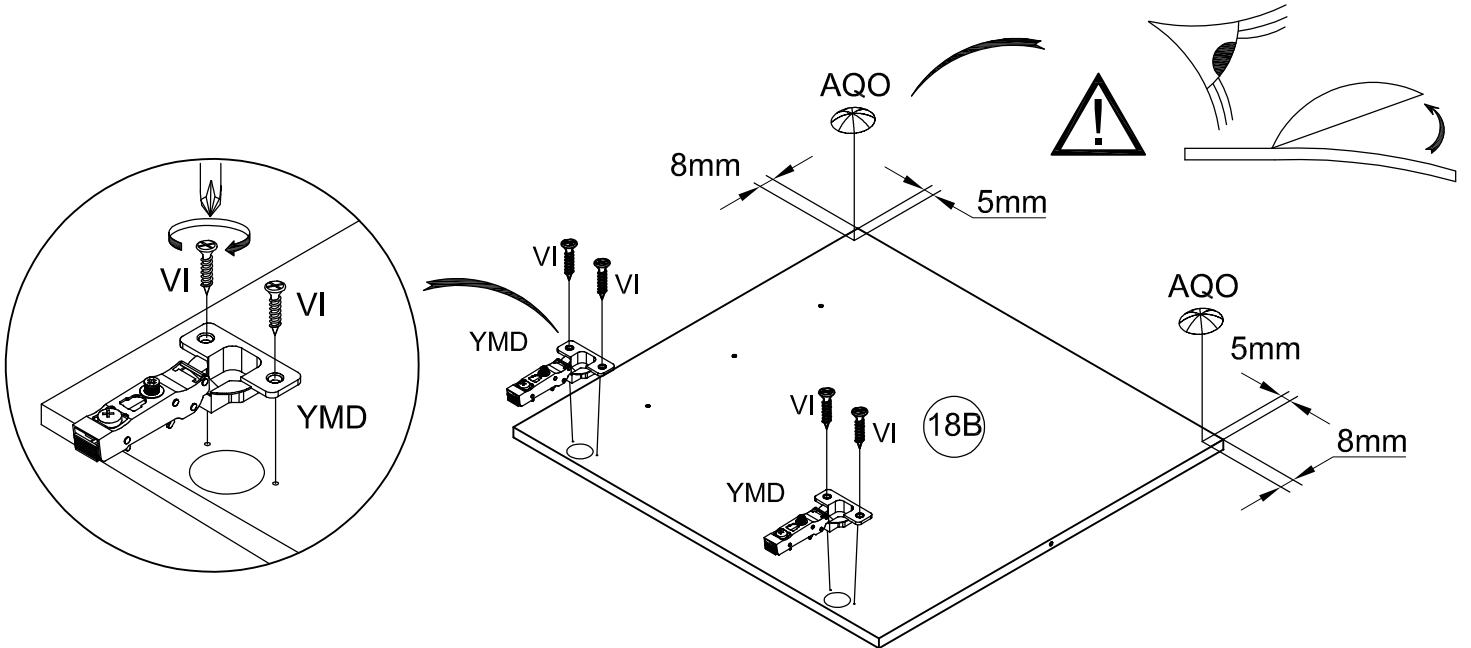
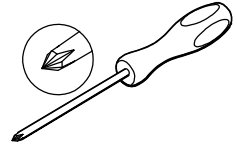

37

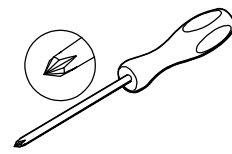

N1071_03

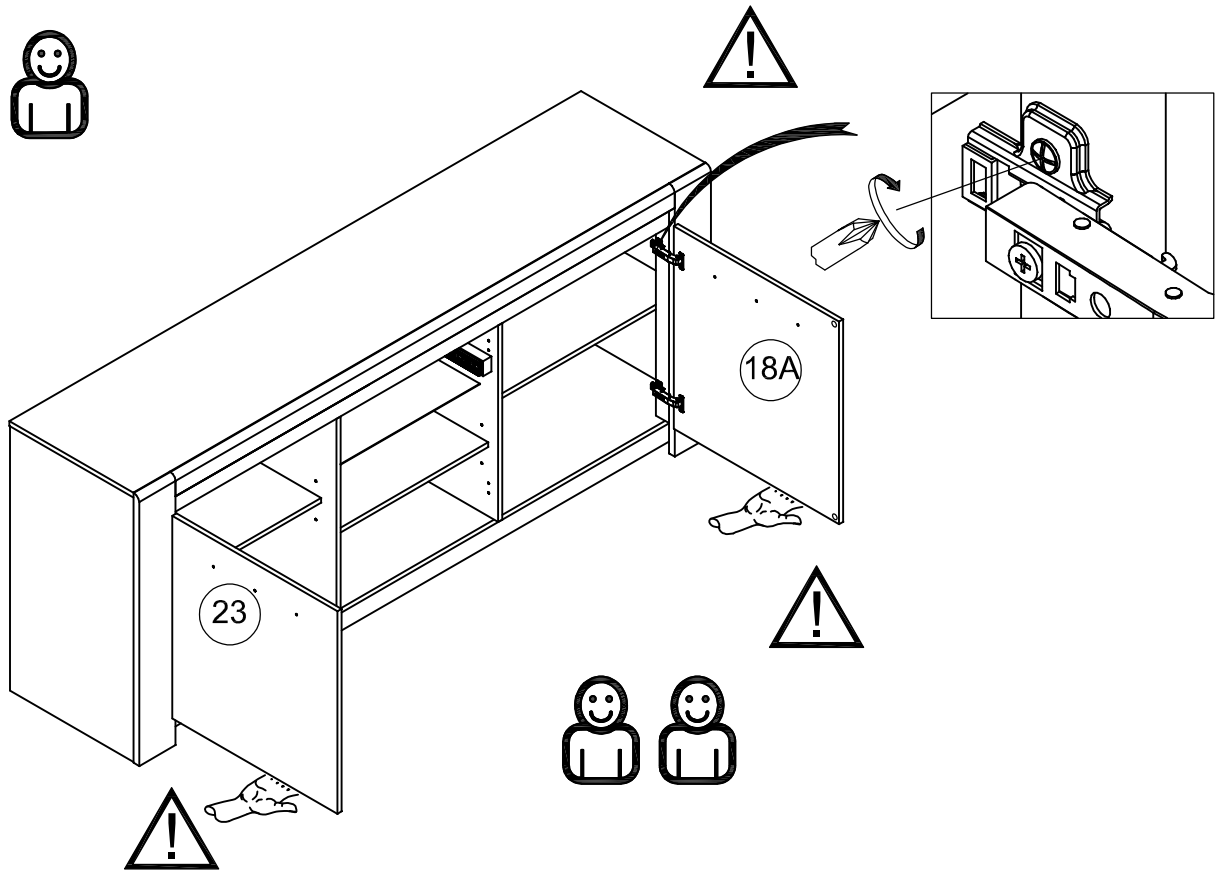
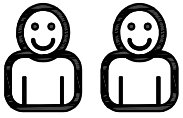

38

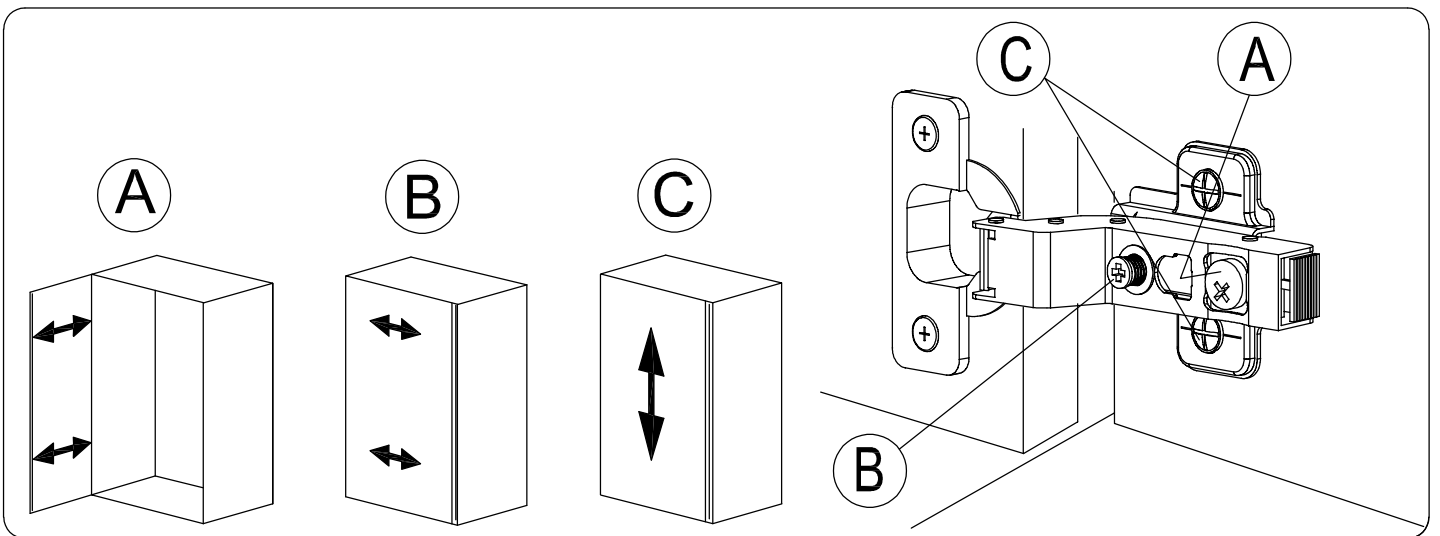

39

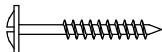

WH x 6



YNA x 2

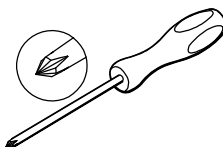

N1071_03

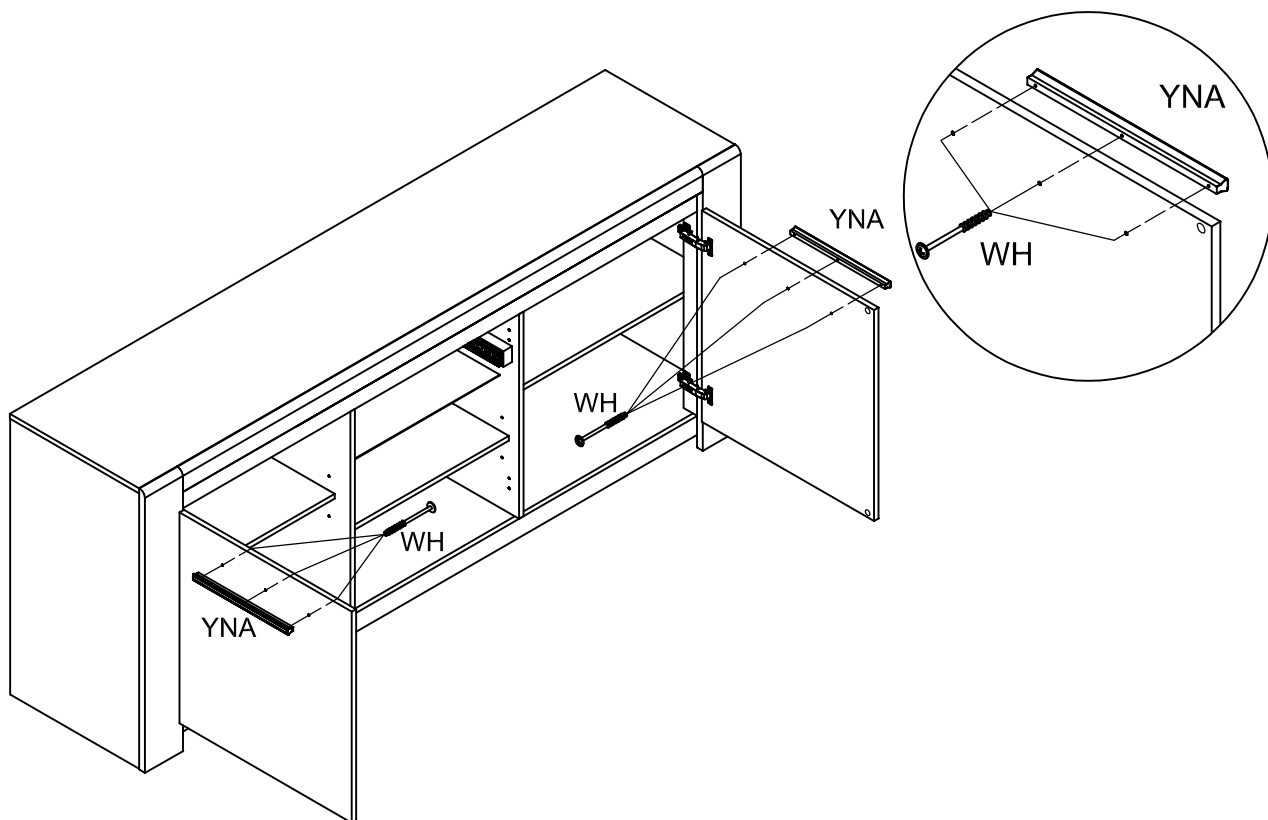

40

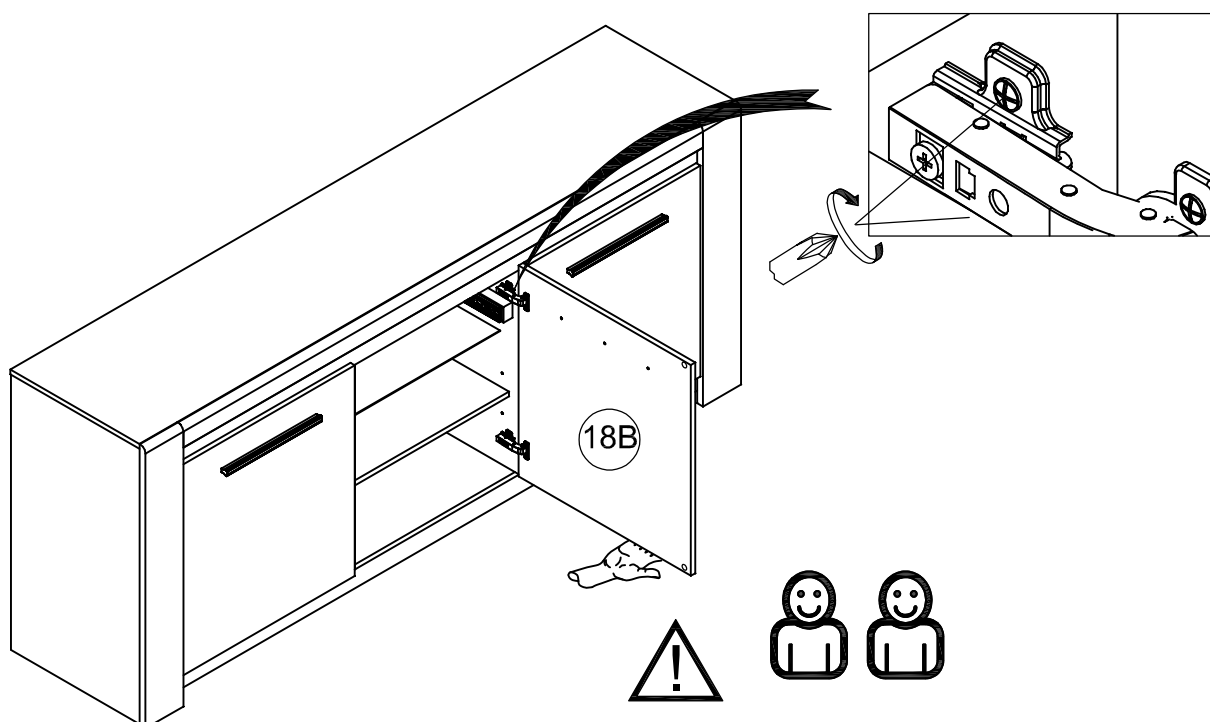

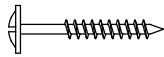
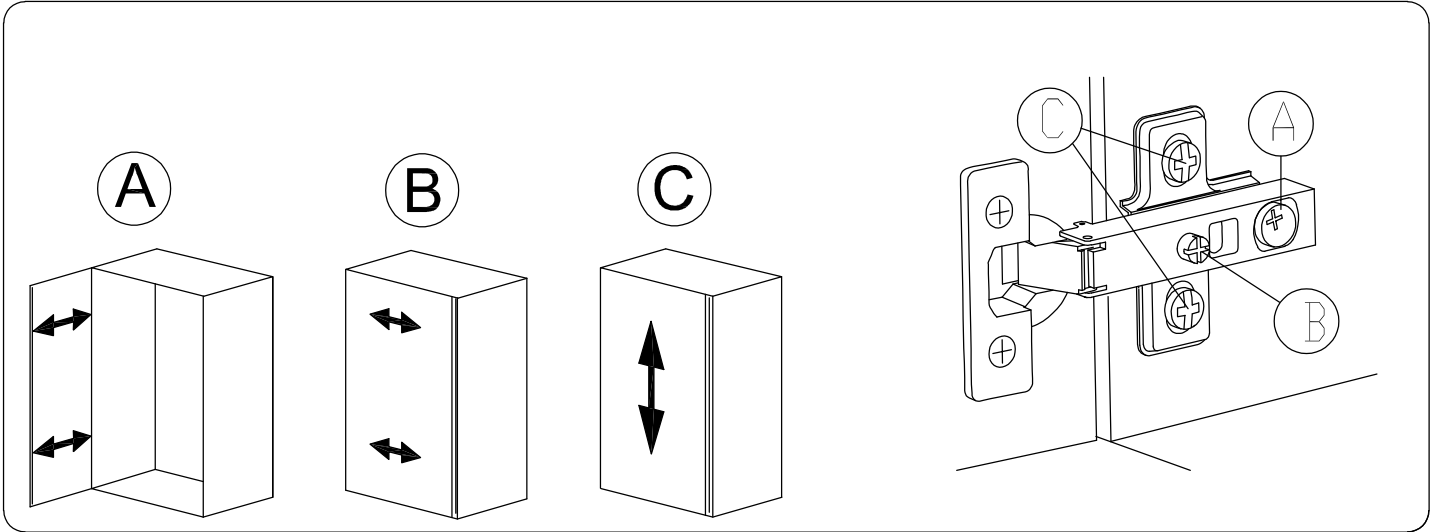

WH x 3



YNA x 1

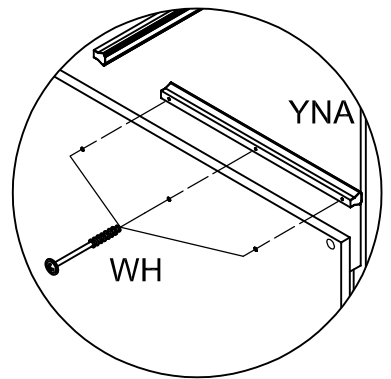
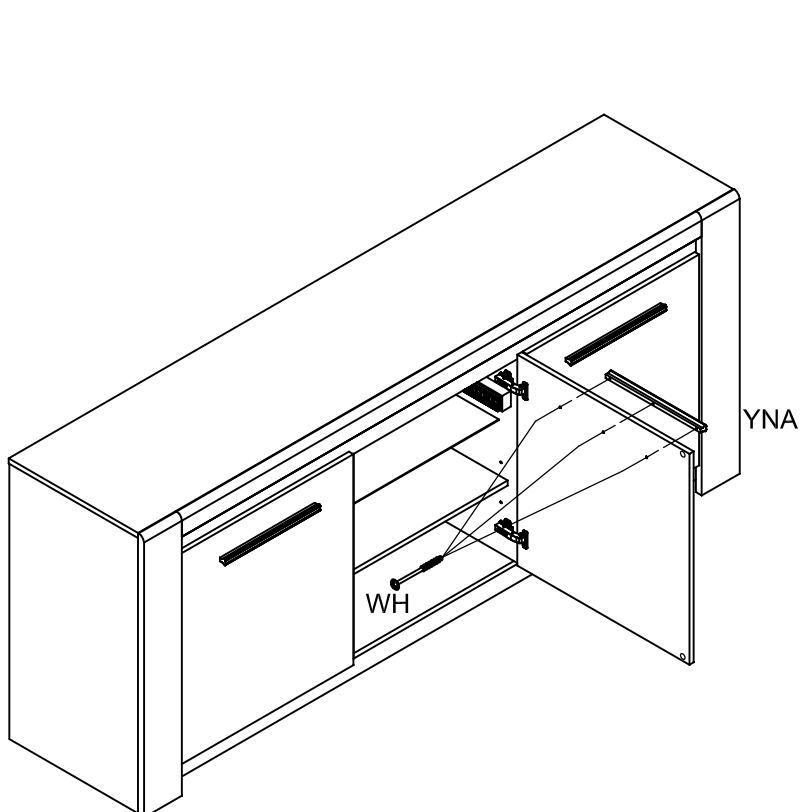
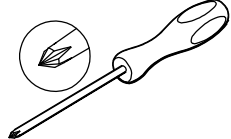

43



BWC x 4

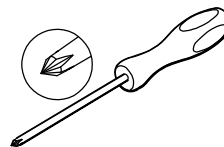

N1071_03

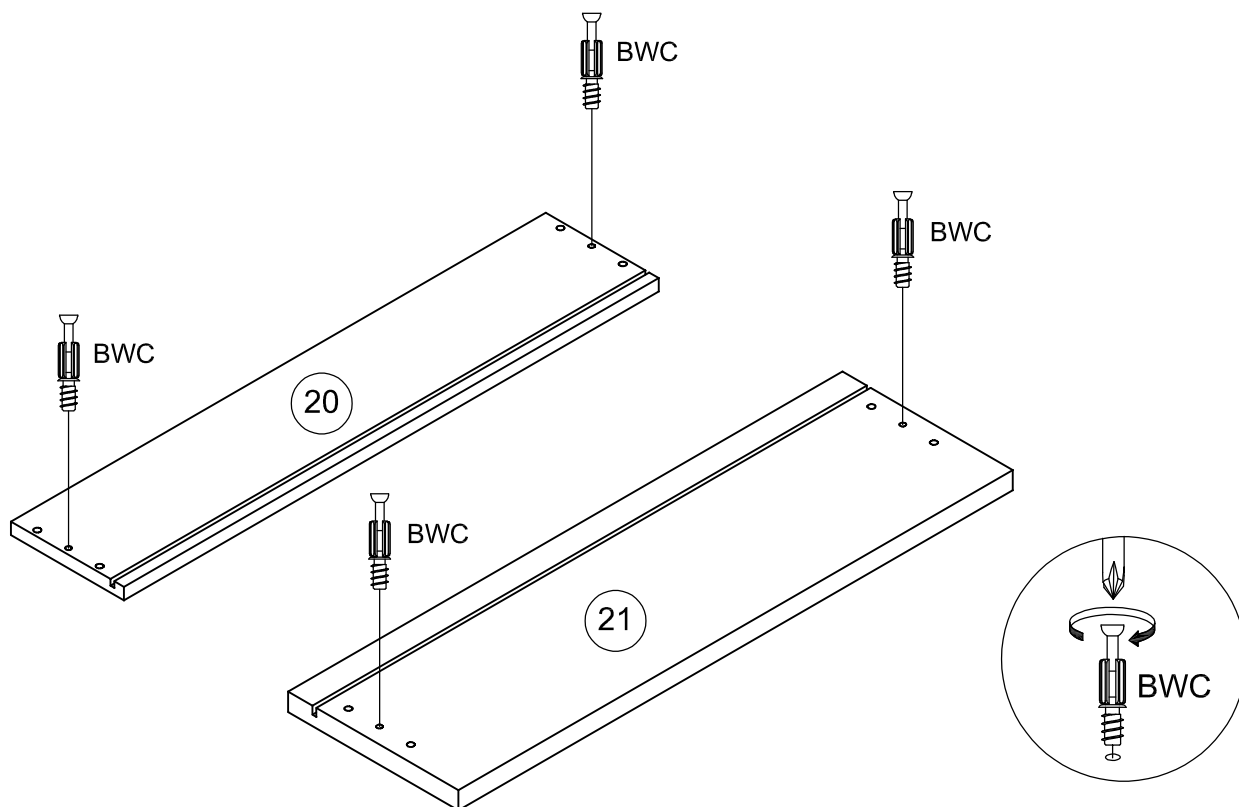

44



AV x 8



BZG x 4

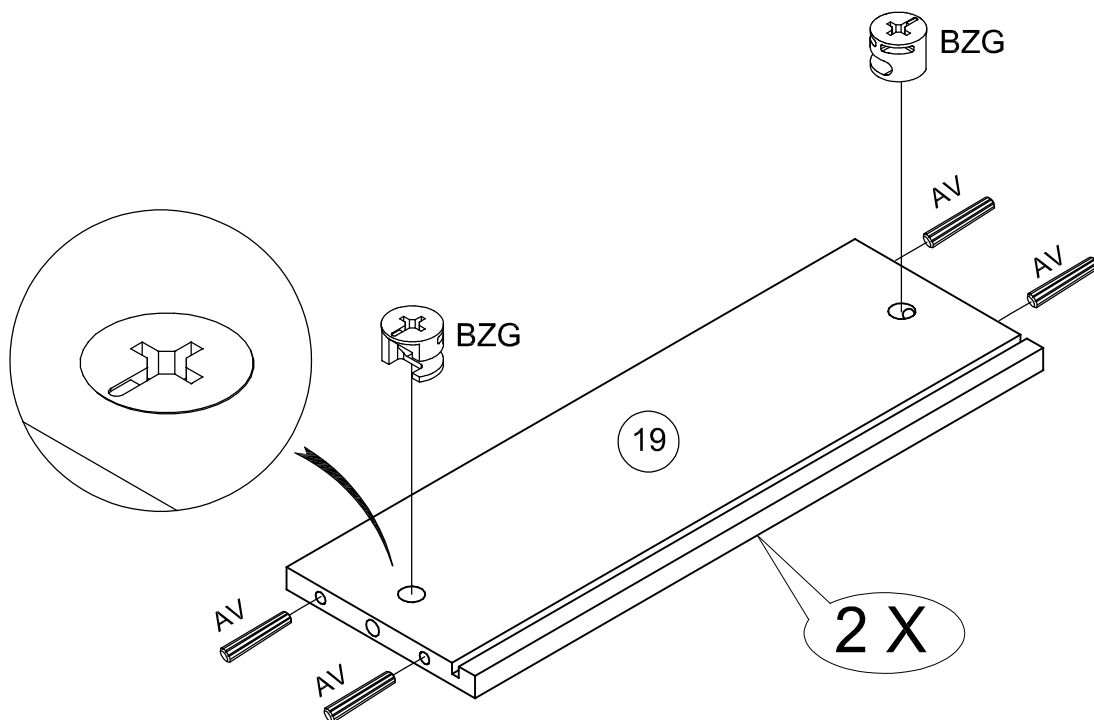
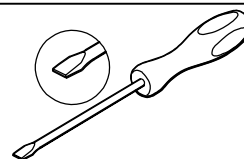

45

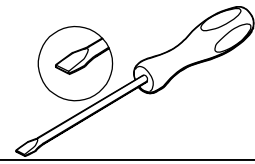

N1071_03

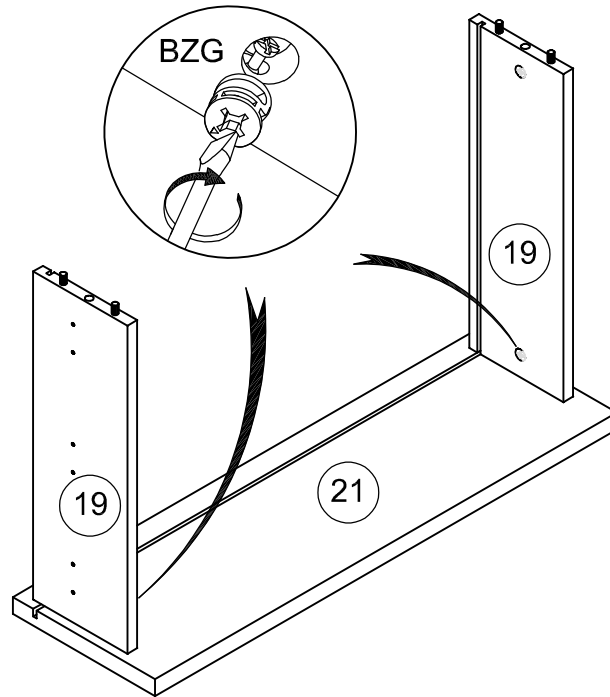

46

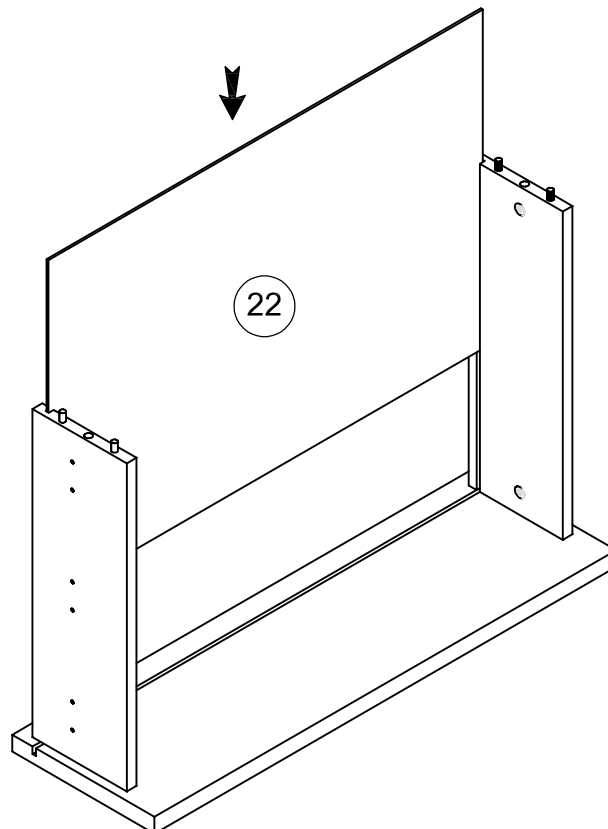
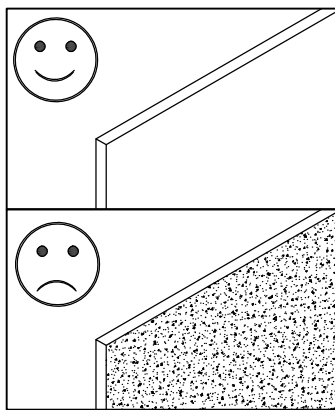

47

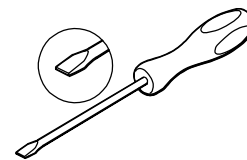

N1071_03

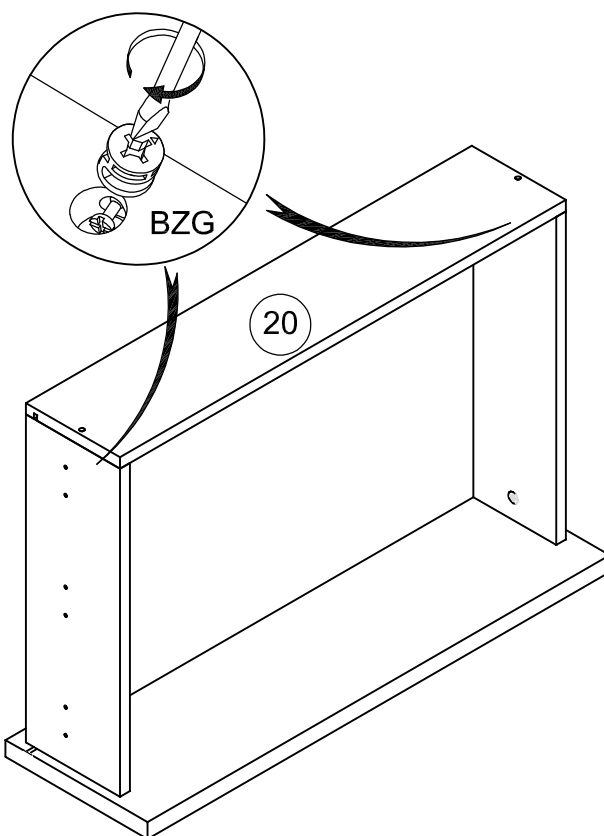

48

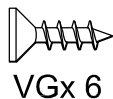

VGx 6

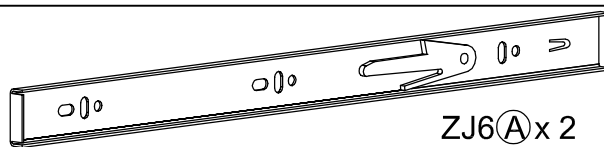

ZJ6(A)x 2

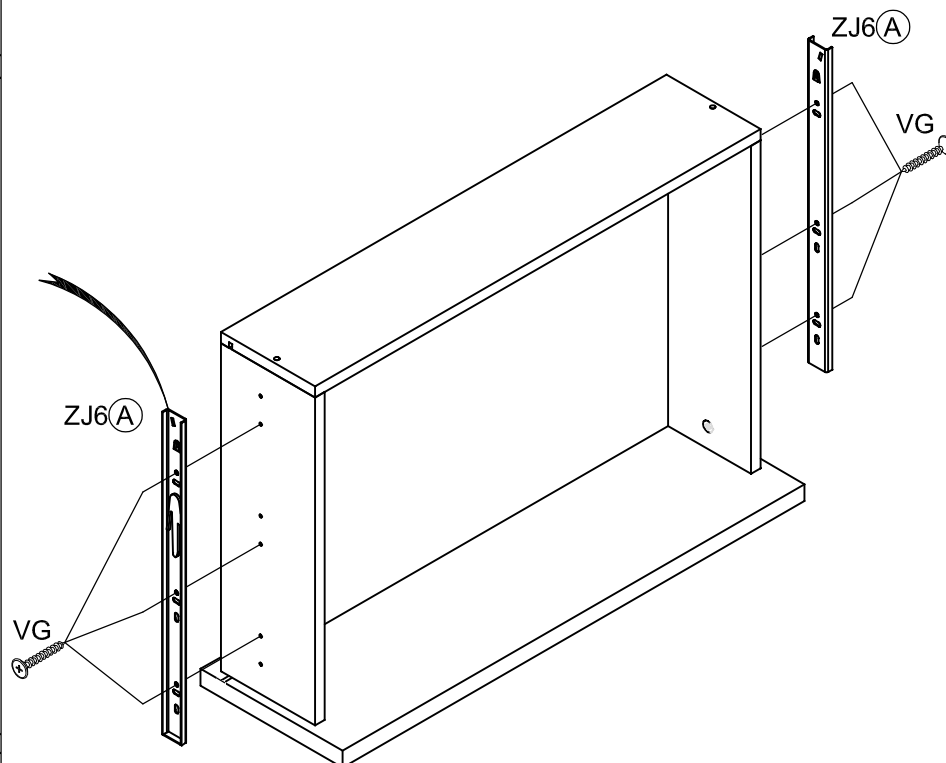
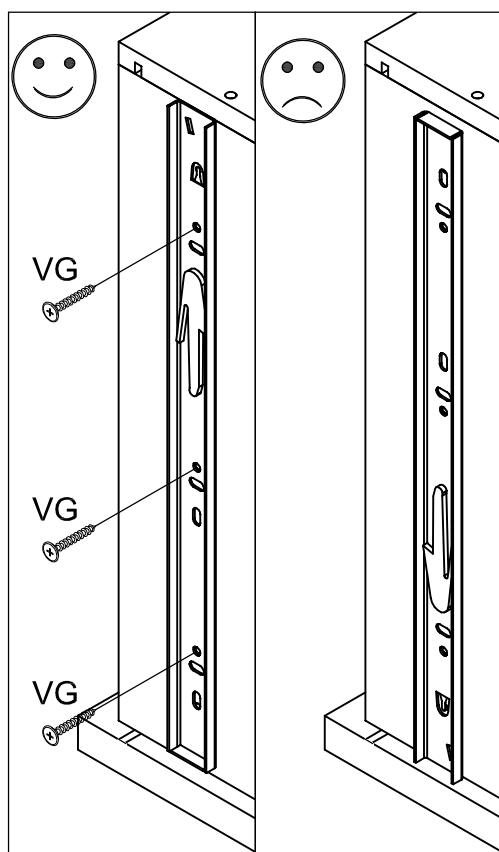
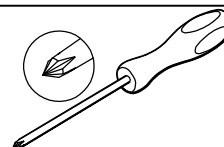

0201 EN3PK-33/38

49

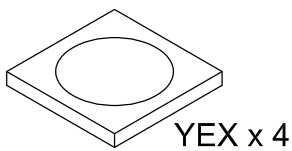

N1071_03

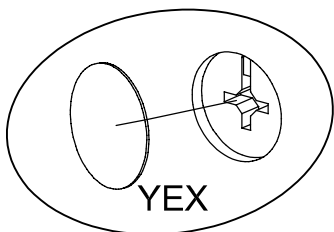
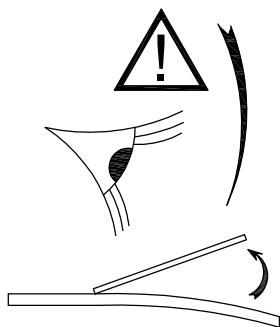

YEX

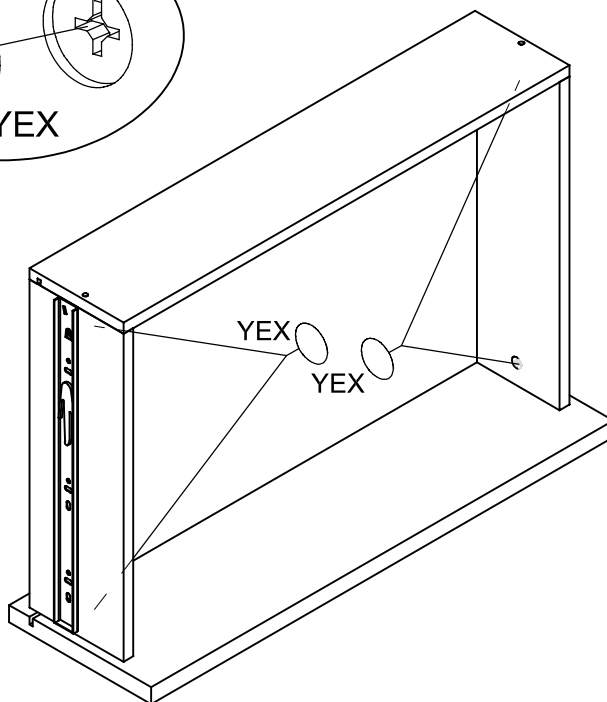

50

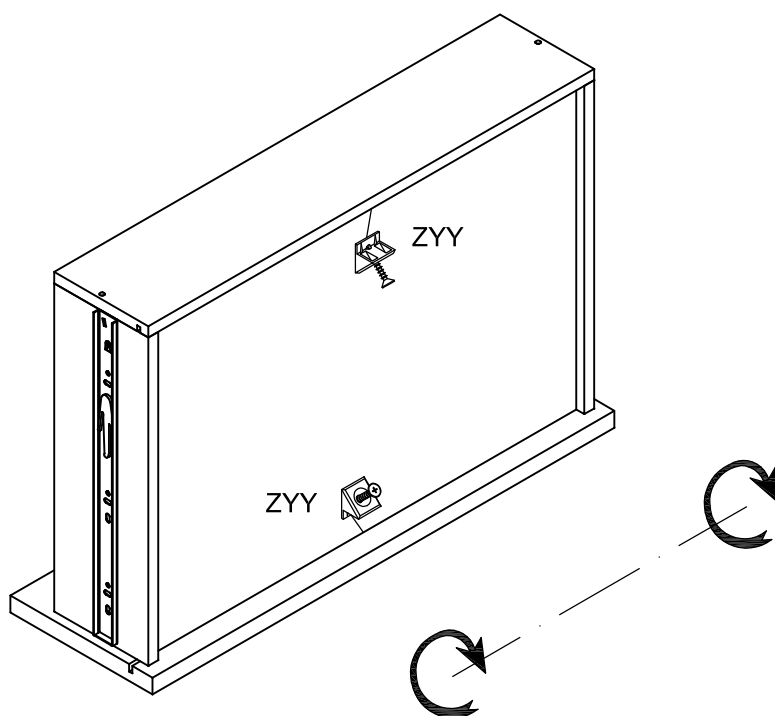
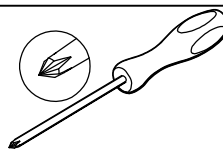
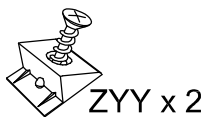

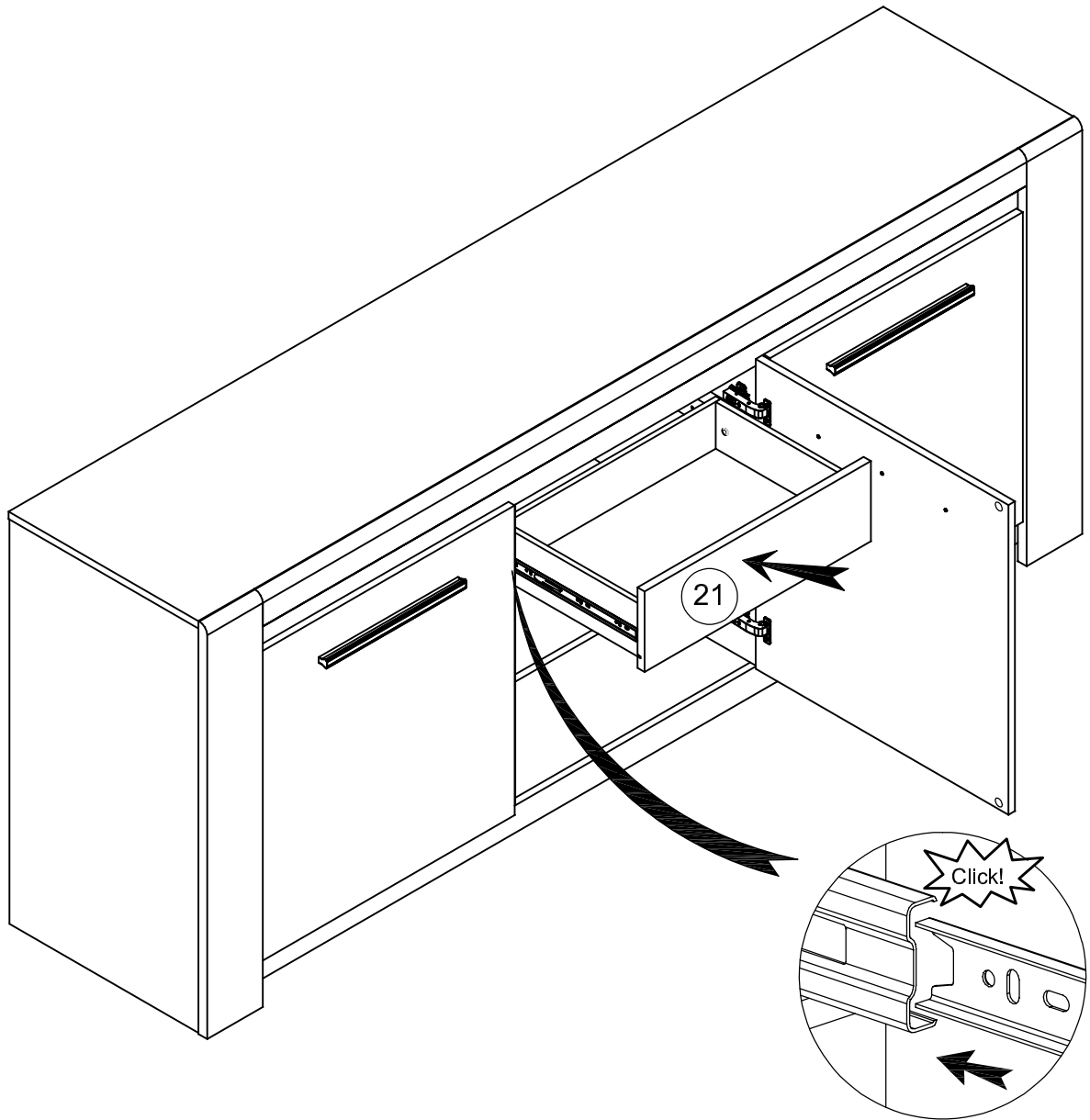

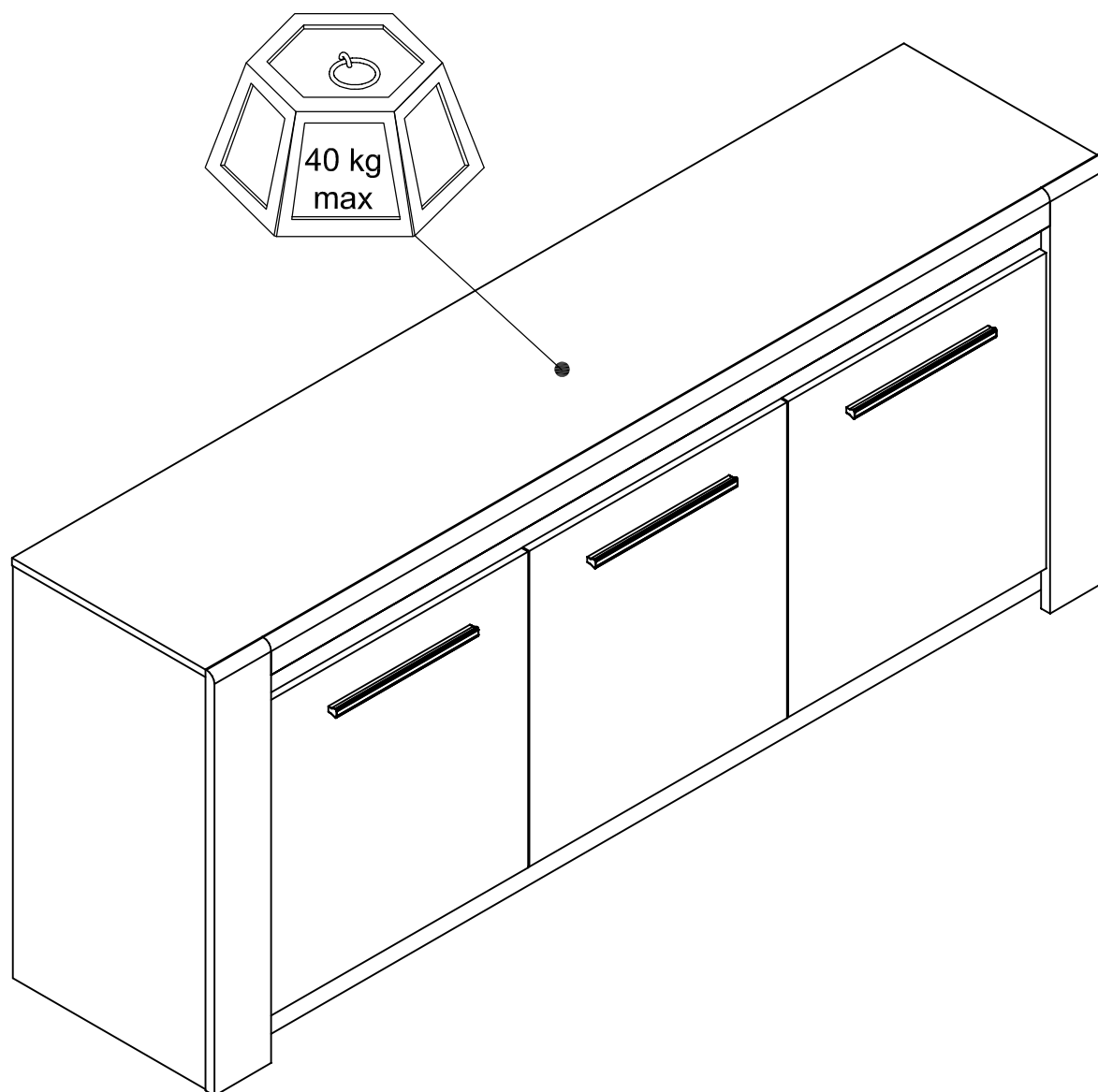

Faites un geste pour l'environnement en triant vos déchets d'emballage
 Make a gesture for the environment by sorting out your waste of packaging
 Machen Sie eine Bewegung für die Umwelt, ihre Verpackungsabfälle sortierend
 Haga un gesto para el medio ambiente escogiendo sus residuos de embalaje

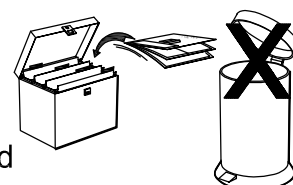

	PENSEZ AU TRI ! ENSEMBLE RÉDUISONS L'IMPACT ENVIRONNEMENTAL DES EMBALLAGES	NOM(S) ÉLÉMENT(S) + MATÉRIAU À JETER	NOM(S) ÉLÉMENT(S) + MATÉRIAU À RECYCLER	
	CONSIGNE POUVANT VARIER LOCALEMENT > WWW.CONSIGNESDETRI.FR			

Conseils d'usage pour l'entretien de votre meuble

Nettoyage :

- a) Ne jamais utiliser de chiffons abrasifs mais toujours un tissu doux et légèrement humide, éviter de frotter la surface fortement
- b) les produits de nettoyage doivent être des produits à base naturelle, jamais d'eau de Javel , d'alcool , de solvant, d'ammoniaque
- c) produits suggérés : eau avec léger savon naturel ou produits pour le verre .

Recommandations :

Resserrez les vis et les assemblages après quelques temps d'usage (lit, table, bureau, charnières).

Afin de prévenir d'inutiles pressions sur les points d'attache, nous vous recommandons de placer vos meubles sur une surface plane.

Si vous souhaitez déplacer votre meuble, pensez à le vider et enlever les tablettes verres. Sans cela, vous pourriez abimer le meuble et le sol.

Si vous posez des casseroles, cafetières, tasses, etc. nous vous recommandons d'utiliser des dessous de plats.

Si vous renversez un liquide, utiliser immédiatement un chiffon sec pour essuyer la surface jusqu'à ce qu'elle soit entièrement sèche.

Recommandations spécifiques pour les meubles hauts (>600mm):

Pour des raisons de sécurité, tous les meubles hauts disposent d'un dispositif d'accrochage au mur, disponible à l'intérieur de votre colis. Si tel n'est pas le cas, veuillez en faire la demande auprès de votre revendeur. Cela empêche toute chute accidentelle du meuble.

La qualité de nos produits et votre entière satisfaction, font l'objet de toute notre attention. En cas de questions ou de remarques, n'hésitez pas à en faire part à votre revendeur.

Nous espérons que ce meuble vous apportera entière satisfaction.

ATTENTION !

"Les meubles contenant des panneaux à base de bois (panneaux de particules, panneaux de fibres, contreplaqué...) peuvent émettre des substances polluantes dans l'air intérieur. Il est ainsi recommandé, après l'installation du meuble dans son logement, d'aérer fréquemment la pièce concernée pendant au moins quatre semaines afin de réduire son exposition aux polluants émis par le meuble."

Recommendations for the maintenance of your unit

Cleaning:

- a) Never use abrasive cloth. Use soft moistened fabric and try not to rub the surface too hard.
- b) Use natural cleaning agents, never those containing bleach, alcohol, solvent or ammonia water.
- c) Suggested products: water with a small quantity of natural soap or glass cleaner.

Recommendations:

Tighten the screws and assemblies after some time (bed, table, desk, hinges).

In order to prevent unnecessary pressure on fastening points, we recommend placing your units on a flat surface.

If you want to move your unit, remember to empty it and remove the glass shelves. Otherwise, you could damage your unit and the floor.

If you place saucepans, coffee pots, cups, etc., we recommend the use of coasters or trivets.

If you spill liquid, mop it up immediately with a dry cloth and wipe the surface till it is fully dry.

Special recommendations for high units (>600mm):

For safety reasons, all high units have a system for fastening to the wall, which is supplied in the package. If that is not so, please ask for one from your reseller. That will keep the unit from falling accidentally.

We have taken every step to ensure product quality and your satisfaction. If you have any queries or comments, please contact your reseller.

We hope this unit will meet with your satisfaction.

CAUTION!

“Units containing wood-based boards (chip boards, fibre boards, plywood, etc.) can emit pollutants into the indoor air. That is why the room must be aired frequently for at least four weeks after the unit is fitted in place, in order to reduce exposure to the pollutants emitted by the unit.”